

**2023**  
**Profile**  
**Catalog**

# Company Information

## Location

3760 Highway 82, Glenwood Springs CO 81601

Phone: (970) 930-6123

Email: [roaringforkmoulding@gmail.com](mailto:roaringforkmoulding@gmail.com)

## Office hours

Monday – Friday / 8:30am – 5:00pm

## “Must Know” information:

We have small samples of most of our profiles available in our office.

Maximum thickness of profiles from various thickness of stock:

- 13/16” and under from 4/4 stock
- 1 1/16” and under form 5/4 stock
- 1 1/4" and under form 6/4 stock
- 1 5/8” and under from 8/4 stock

Maximum capacity of our moulder is 10”.

Anything wider than 10” must have the separate parts processed, glued together and processed again through the wide belt planer/sander.

All orders are COD unless prior terms have been approved.

We are not subcontractors and do not work on the draw system. We are suppliers and expect payment when your order is complete.

# Shop Charges

## Set-up Charges:

0 ft - 49 ft                      \$225

50 ft - 199 ft                      \$176

200 ft - 499 ft                      \$132

500 ft - 1,000 ft                      \$88

1,000 ft plus                      No Charge

## Knife Grind Charges

2" = \$200

2.5" = \$215

3" = \$230

3.5" = \$245

4" = \$260

4.5" = \$275

5" = \$290

5.5" = \$305

6" = \$320

6.5" = \$335

7" = \$350

7.5" = \$365

8" = \$380

8.5" = \$395

9" = \$410

9.5" = \$425

## Glue-up Charges:

\$0.85 per ft. per glue line, up to 10"

\$1.70 per ft. per glue line if over 10" wide

## Planer/ Sander Charges:

\$0.40 per ft. per pass or \$45 whichever is greater

## Straight Line Rip Charges:

\$0.40 per ft. per pass or \$25, whichever is greater

## Customers Wood Charges:

\$0.85 per linear ft. for molding. Minimum \$50

Shop Time: \$120 per hour

**Return Check Charge \$35**

# Base/ Case Pages

These profiles generally can be made into both base or case.

Typically, the case will be 1/8" thicker than the base.

Some of these profiles can be thickened to make Plinth blocks or a rabbet added to the back side to use as a mirror frame, or paneling cap.

Our moulder has a maximum width capacity of 10". For wider things, such as, skirt boards or valance material call for information.

The thickest we can mill using 4/4 stock is 13/16", using 5/4 stock is 1", using 6/4 stock is 1/25", and using 8/4 stock is 1/625"

Base / Case Page #1

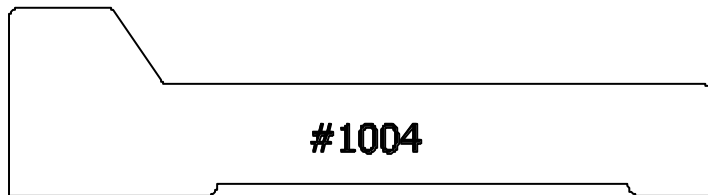
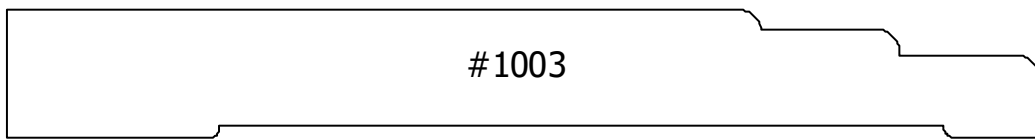
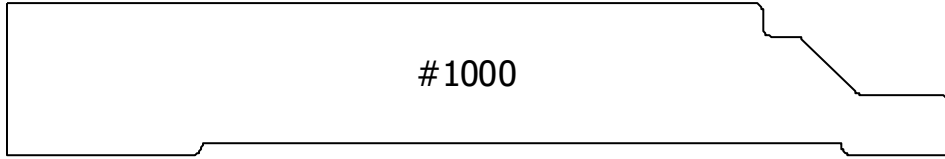

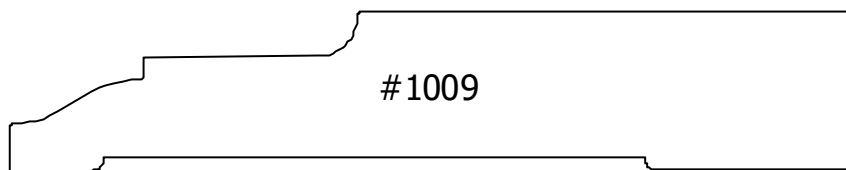
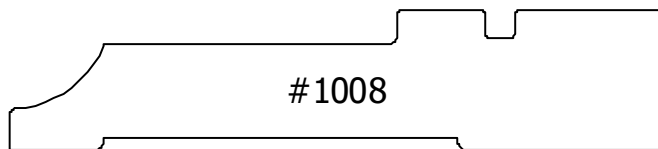
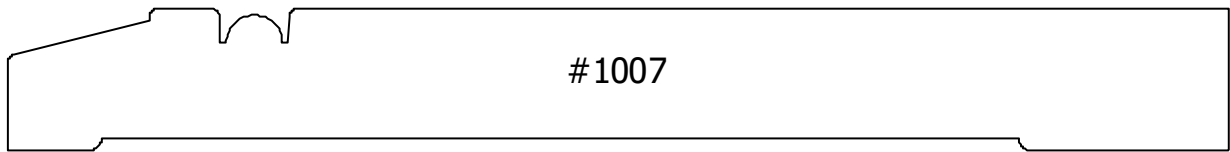
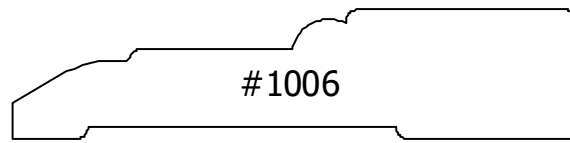

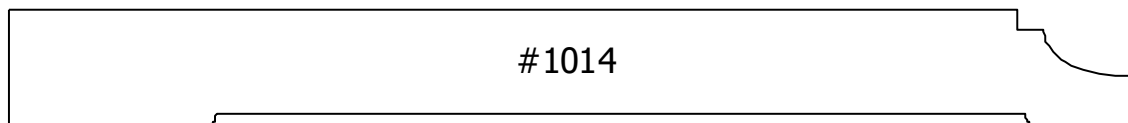
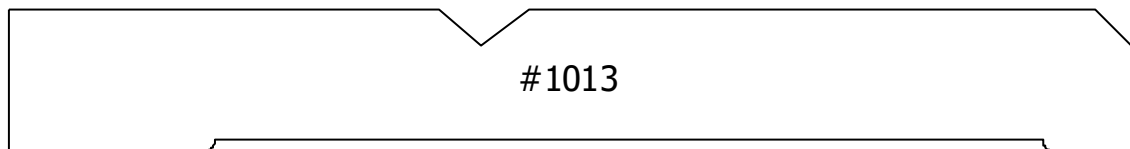
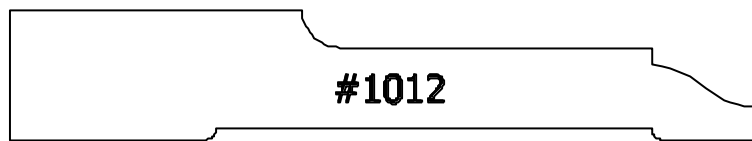
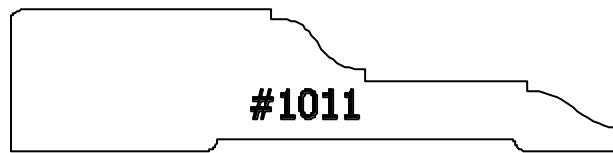
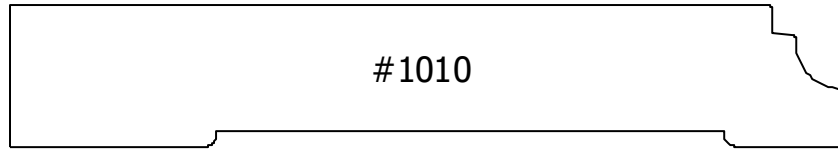

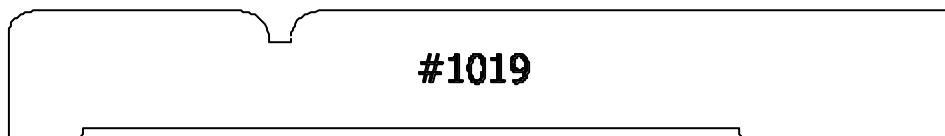
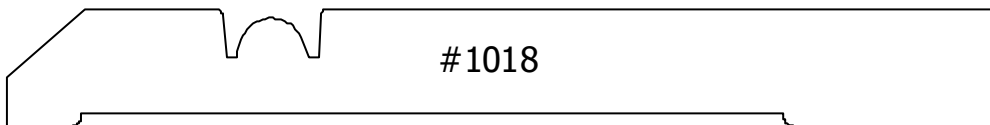
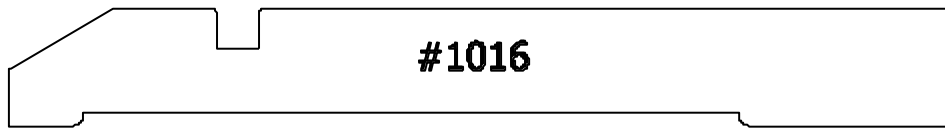
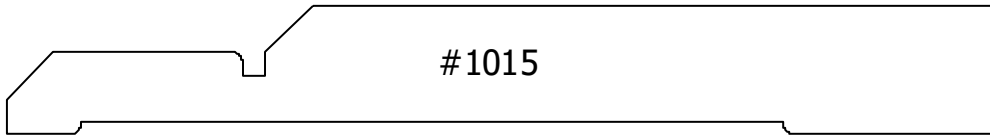



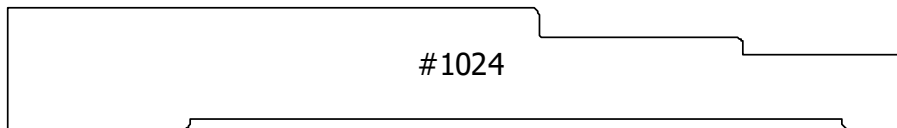
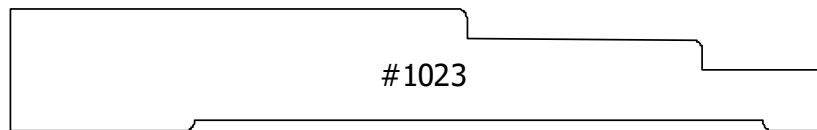
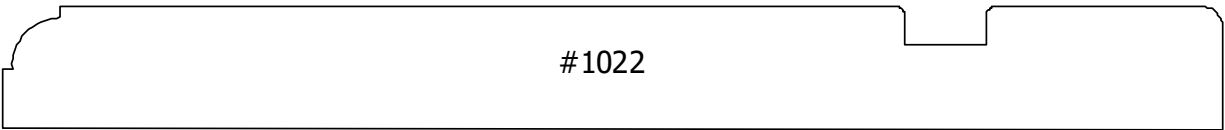
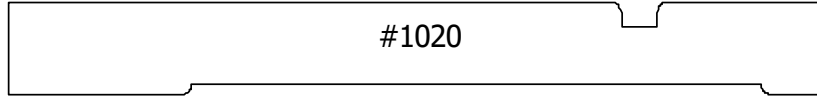

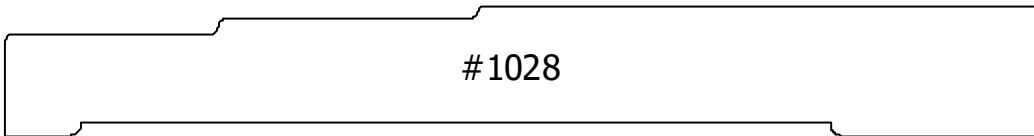
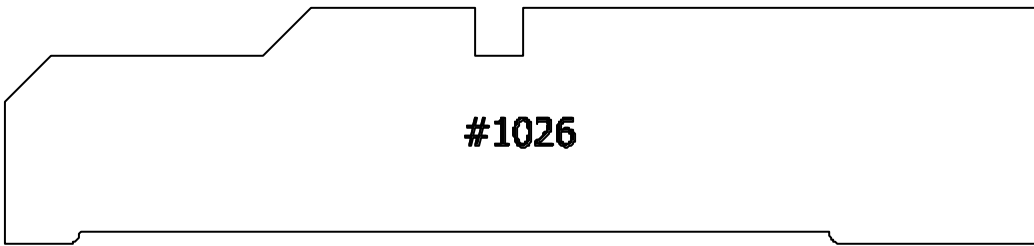
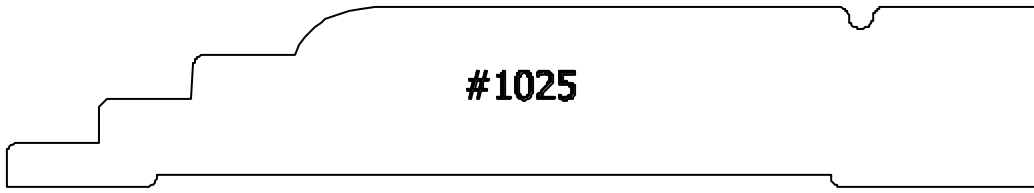

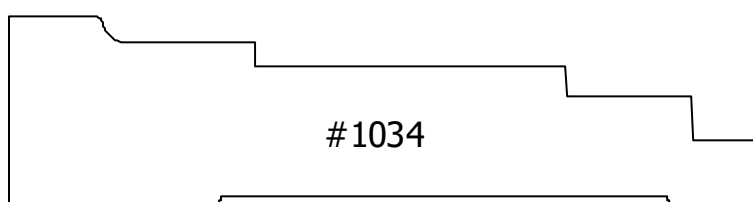
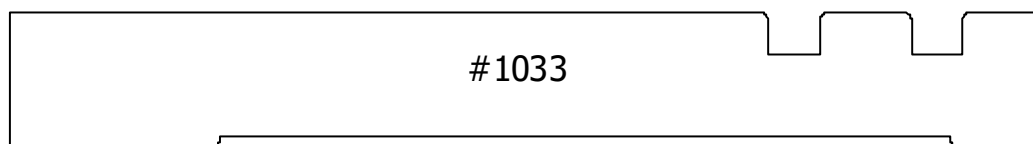
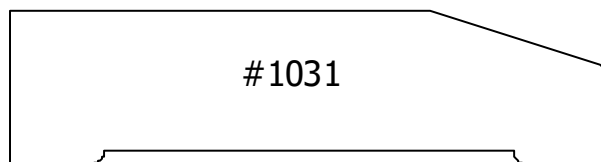

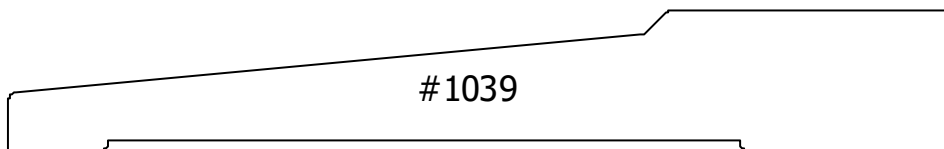
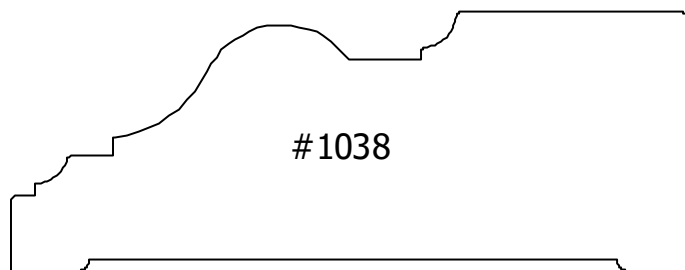
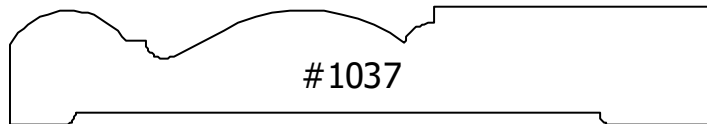
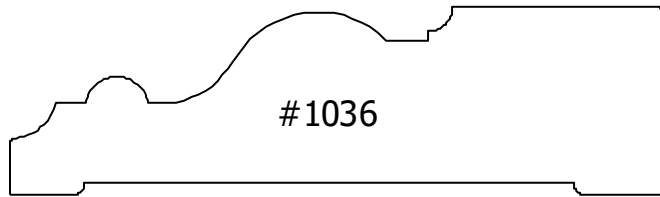
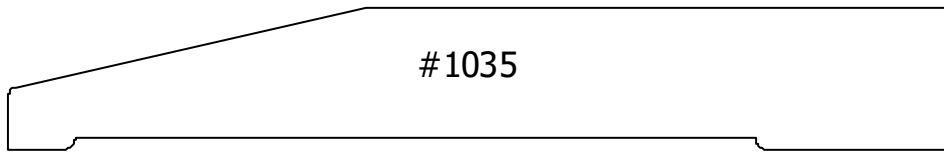

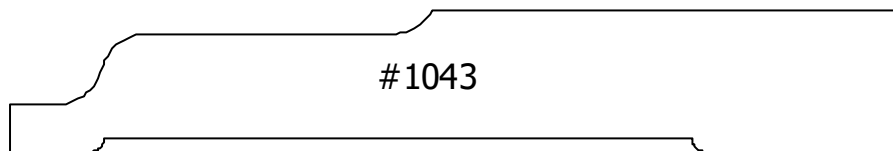
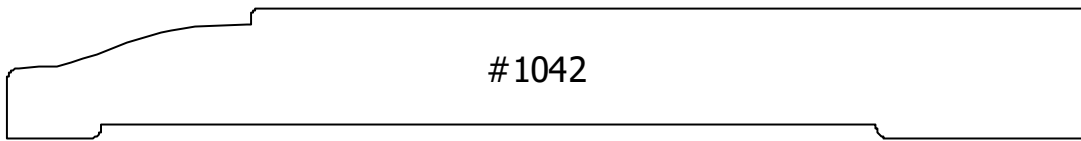
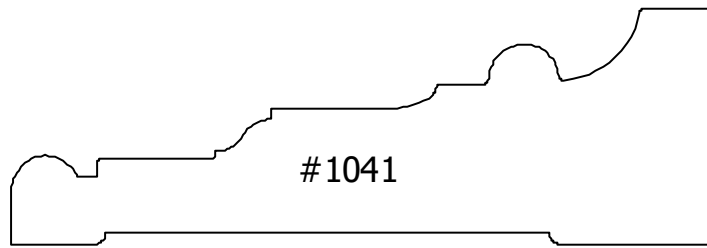

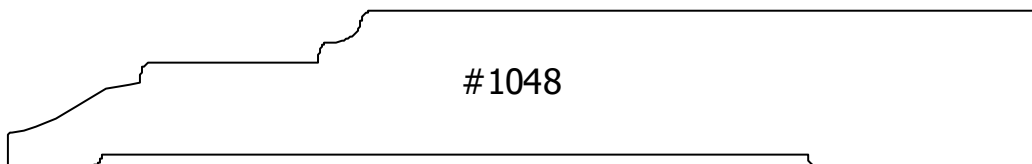
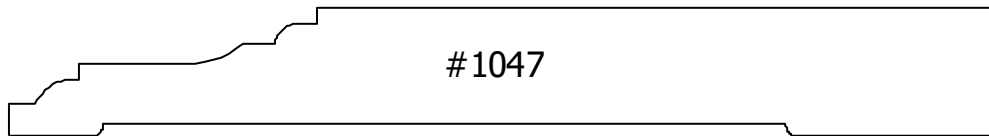
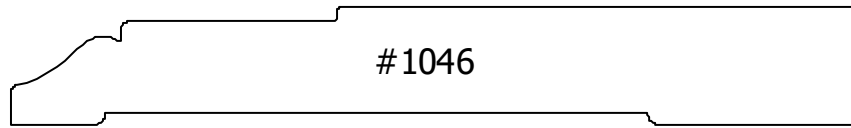

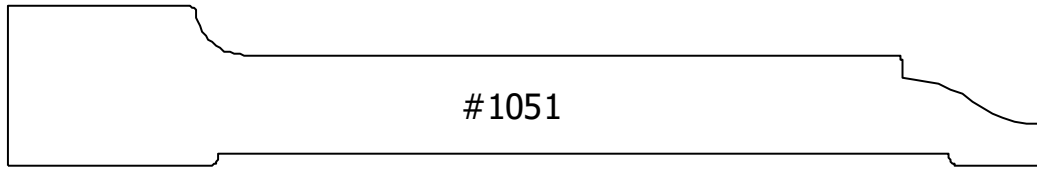

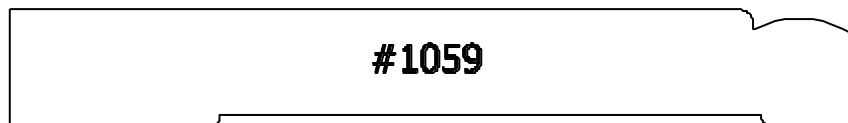
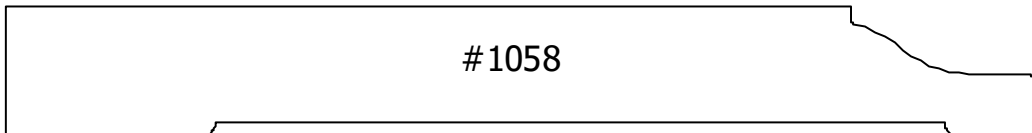
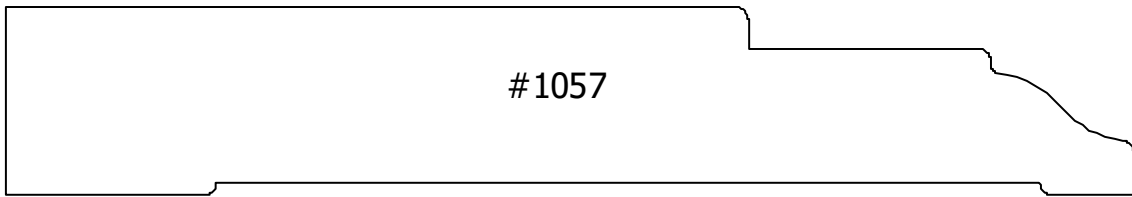
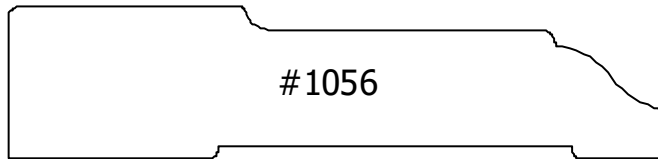
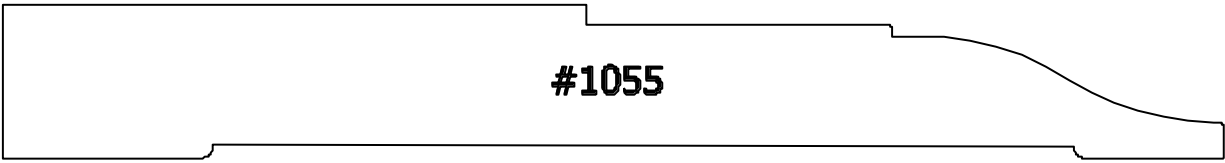



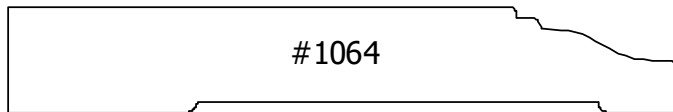
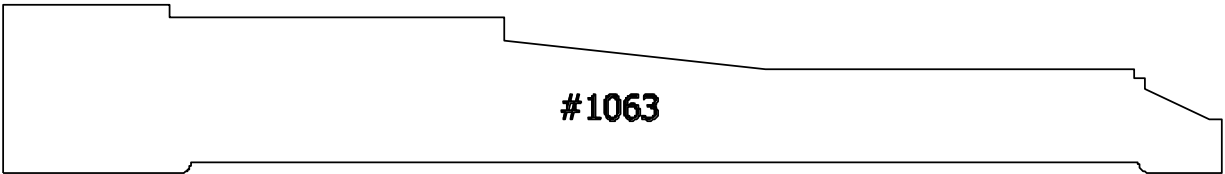
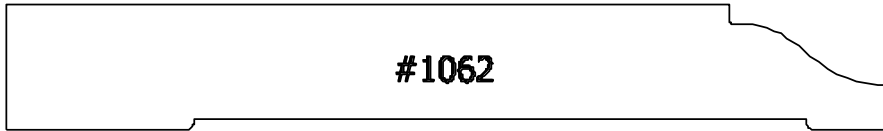
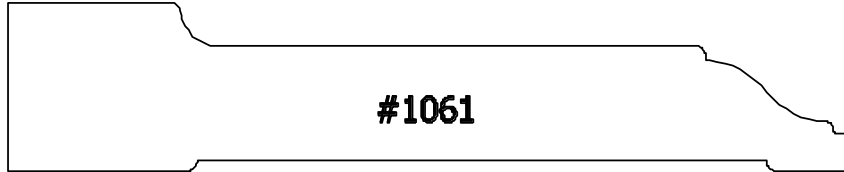
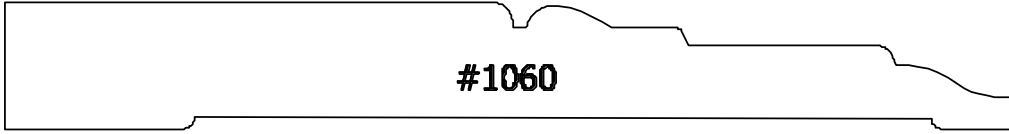

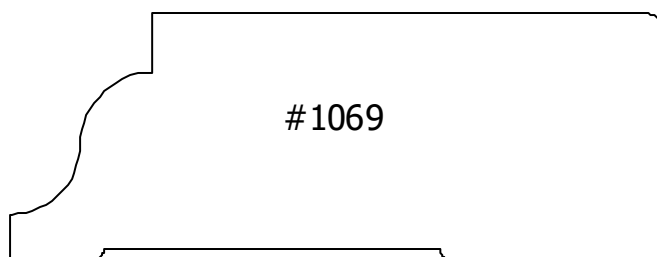
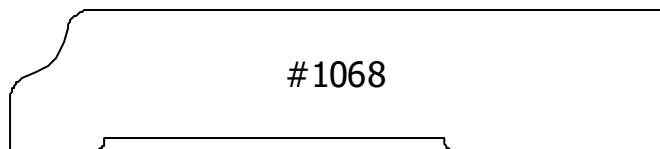
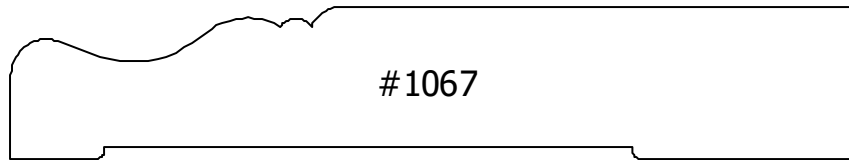
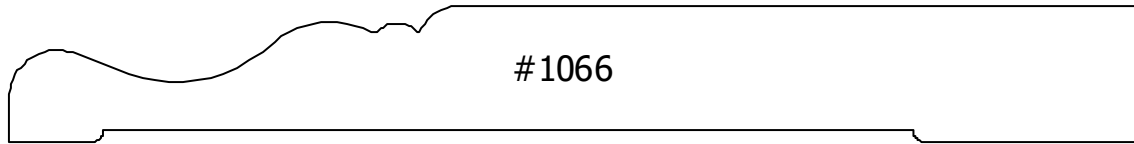
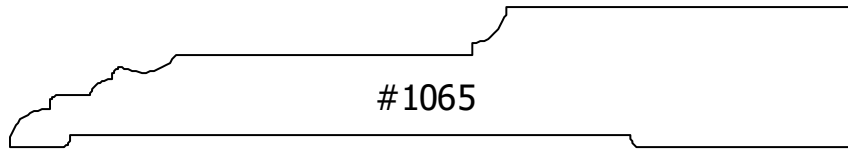

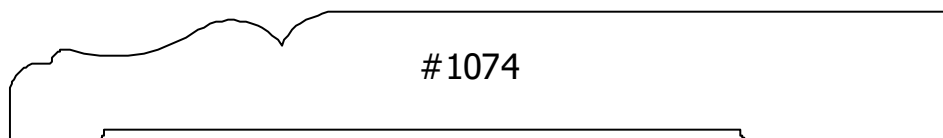
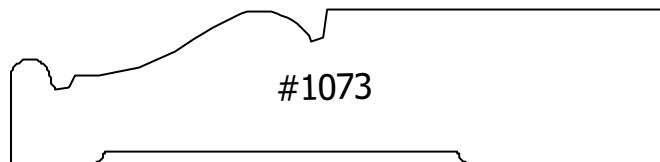
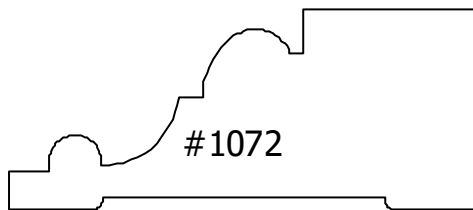
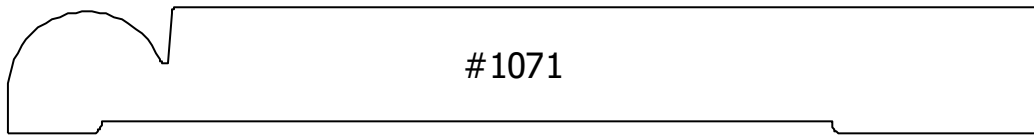
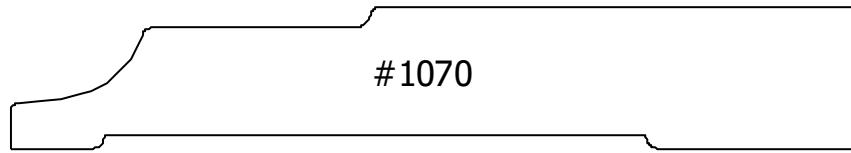

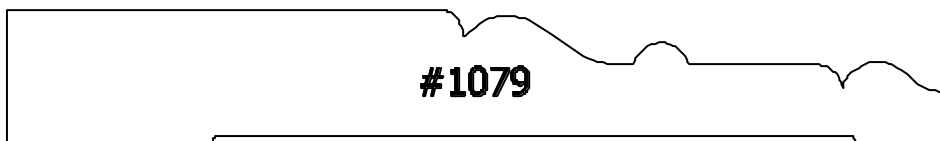
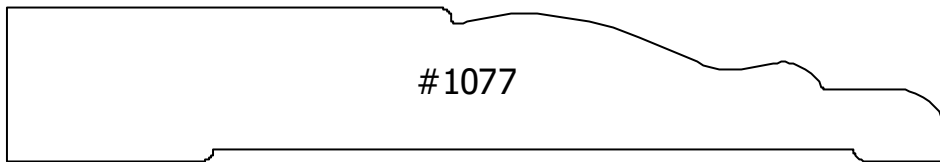
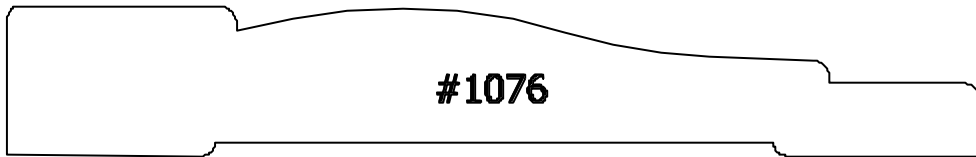

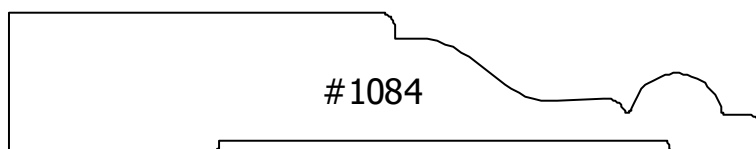
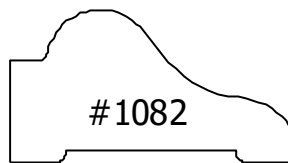
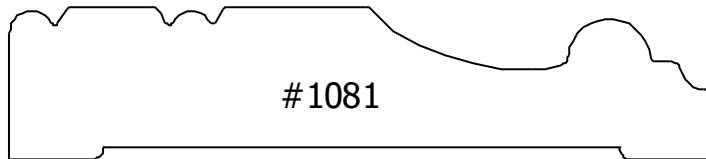
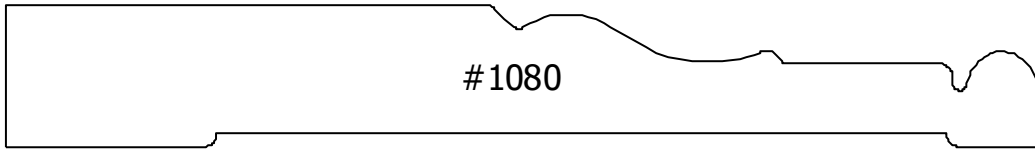

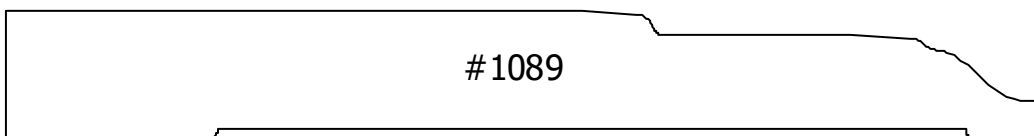
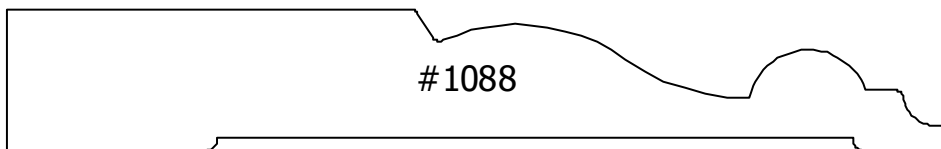
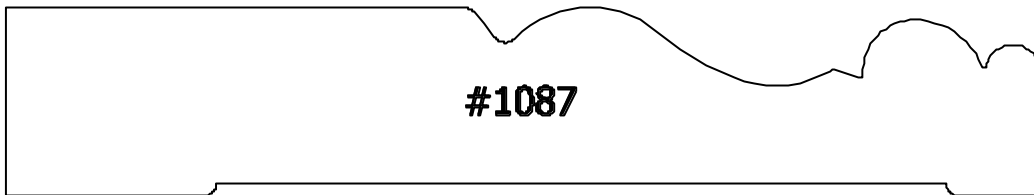
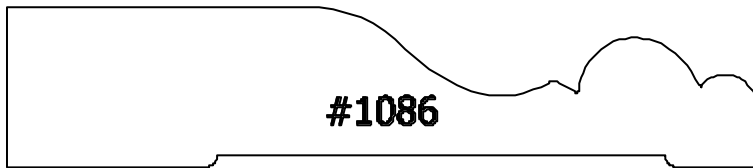
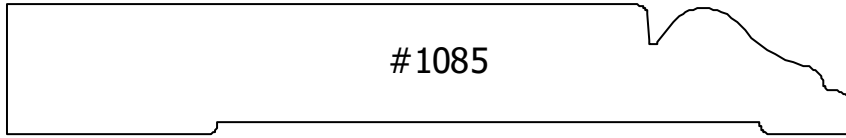

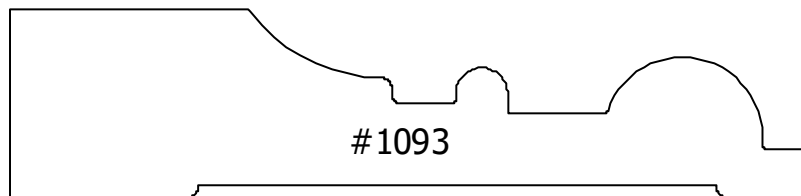
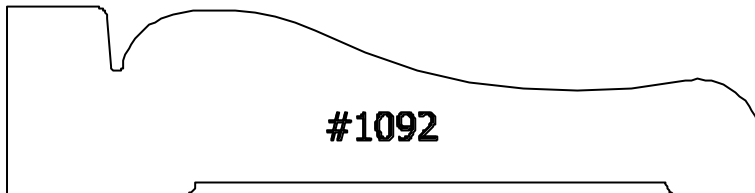
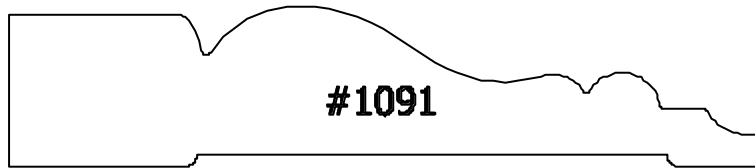

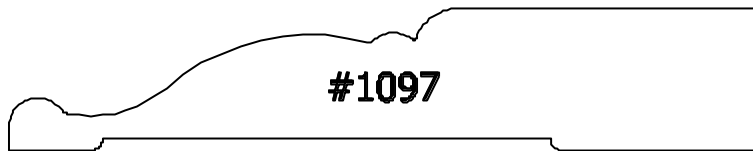
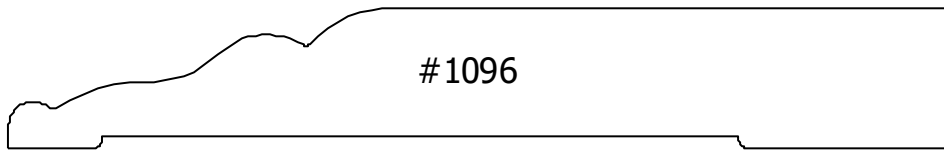
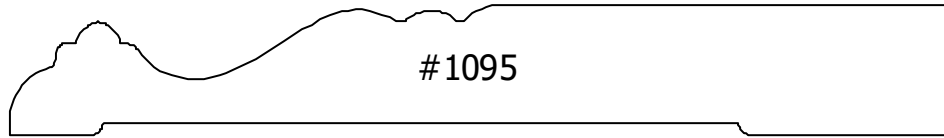



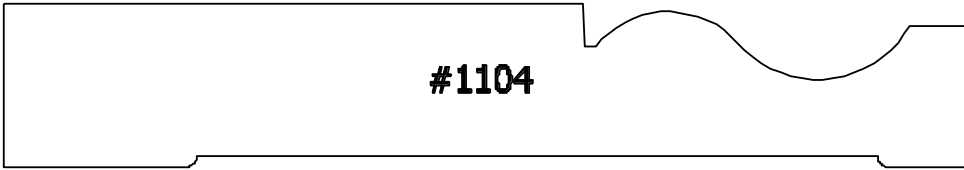
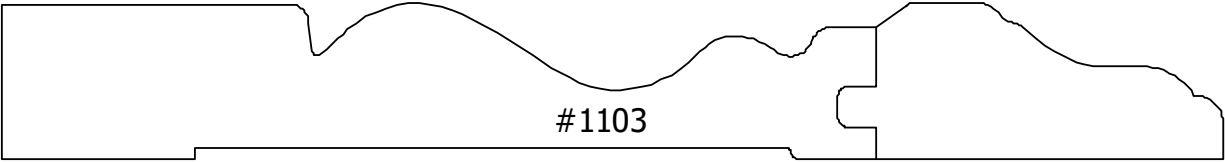
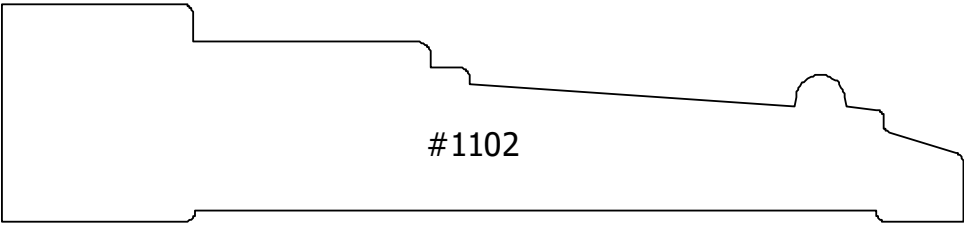
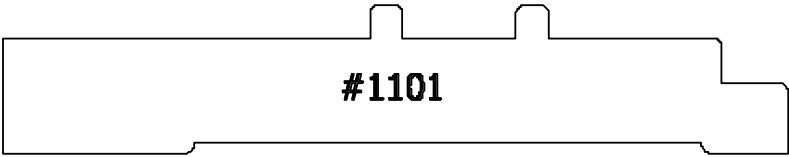
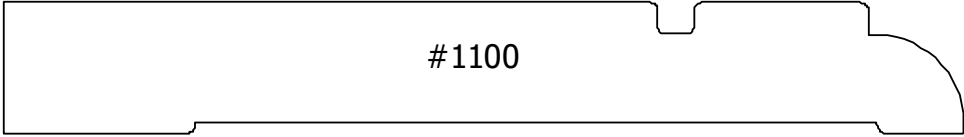

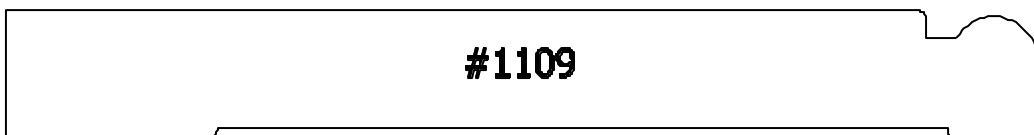
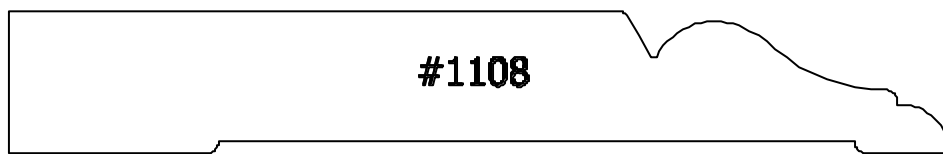
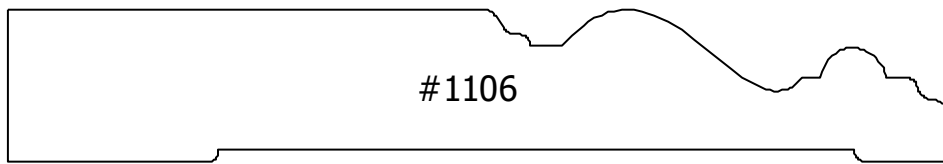
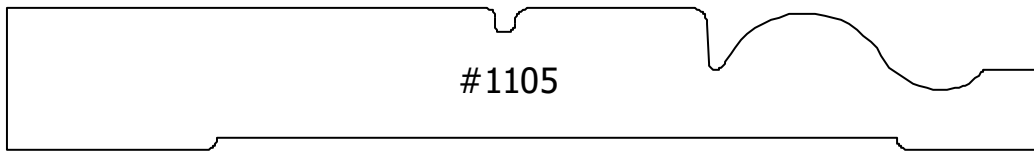

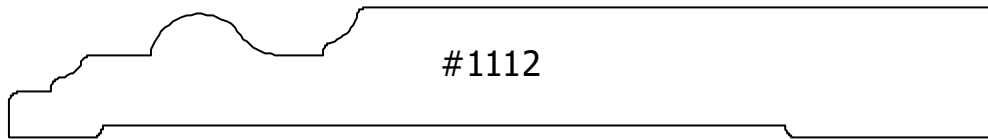
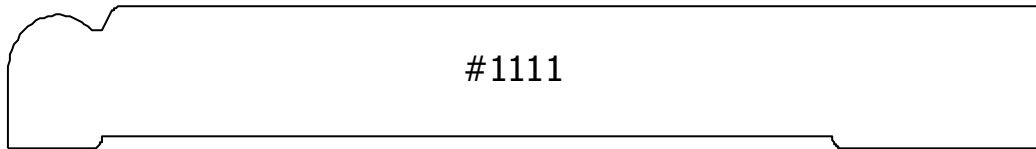
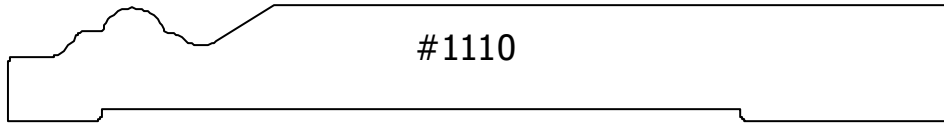

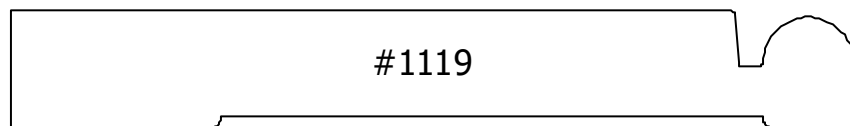
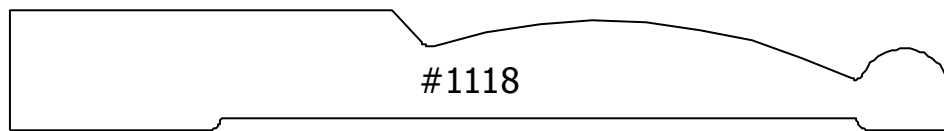
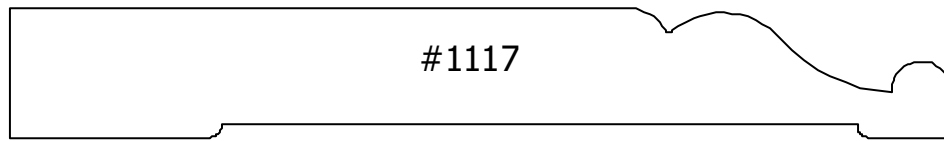
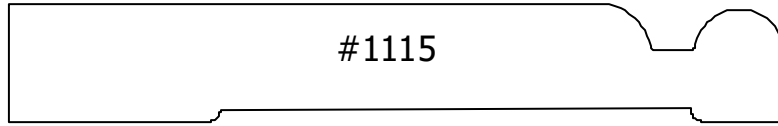

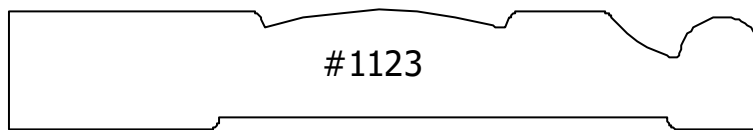
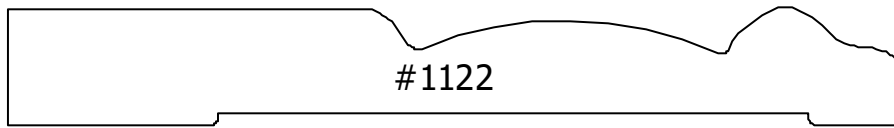
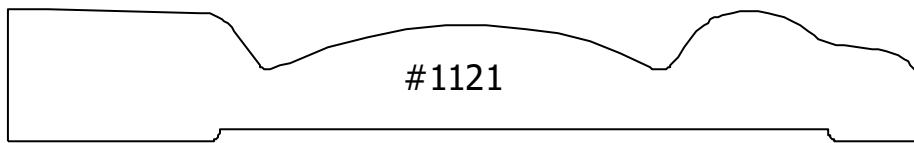
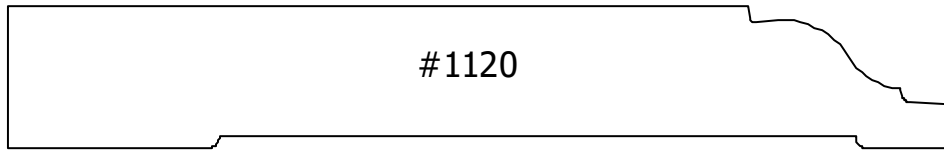

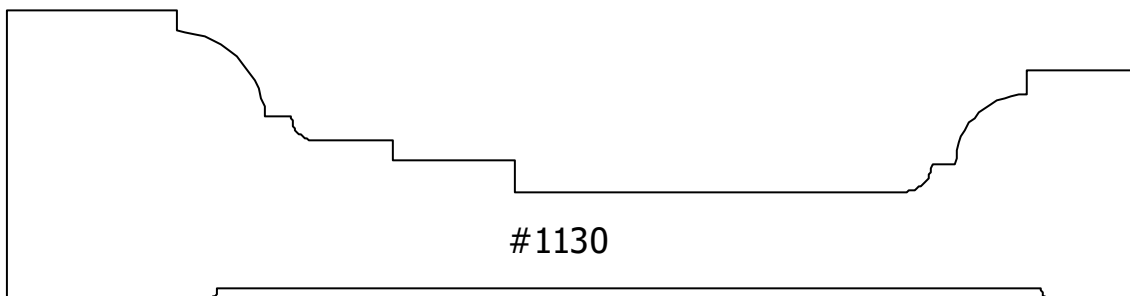
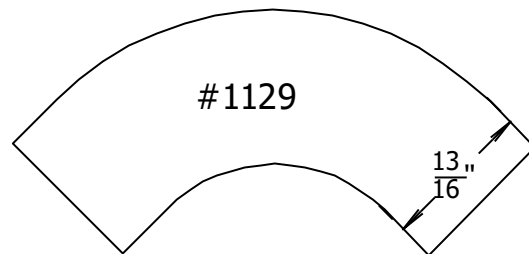
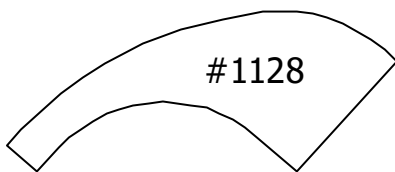
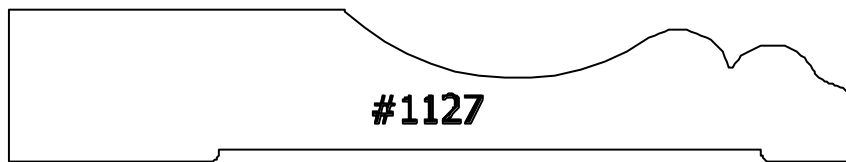
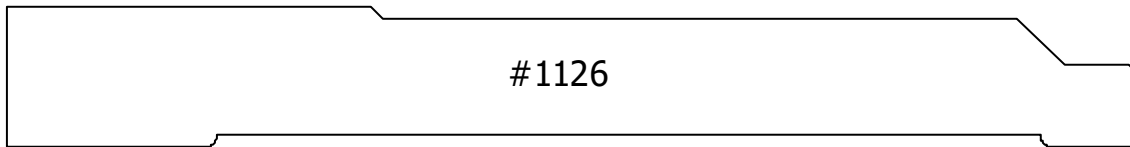

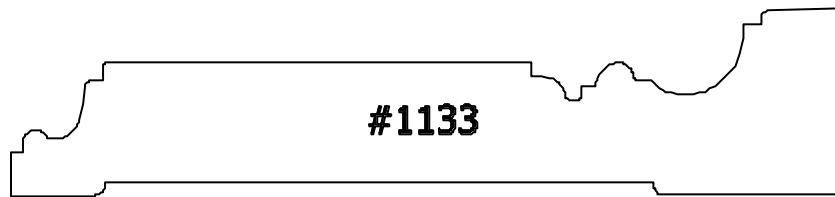
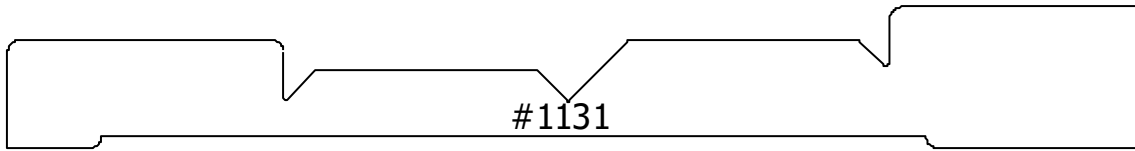

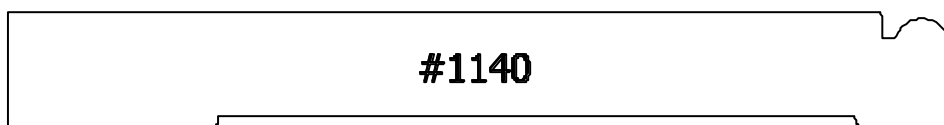
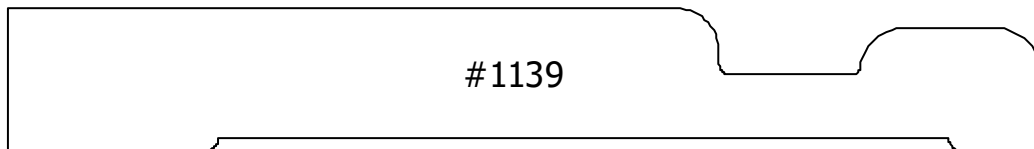
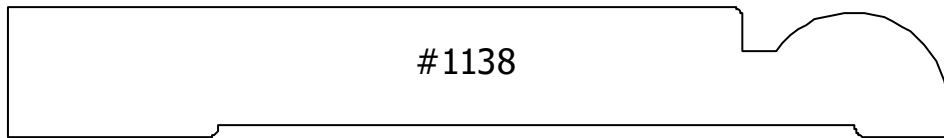
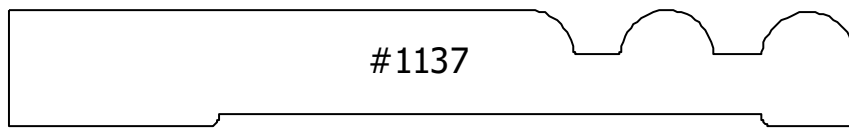
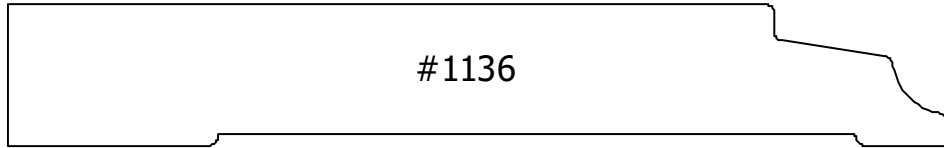



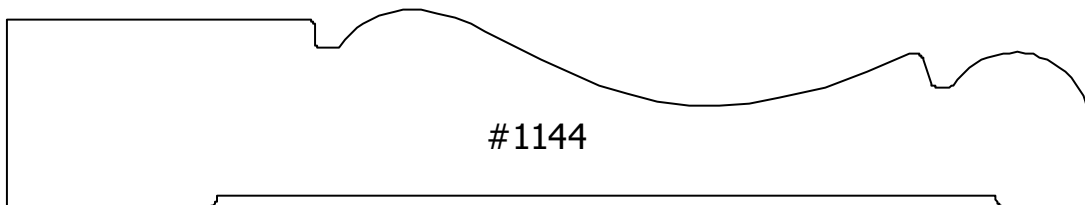
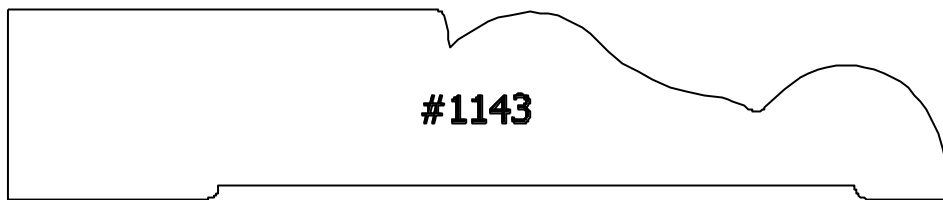
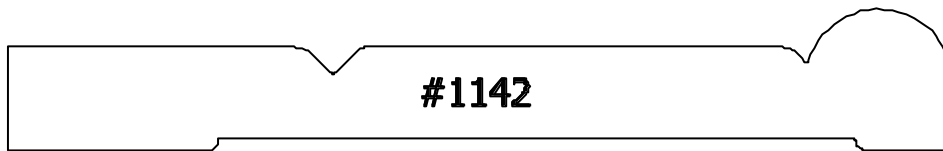
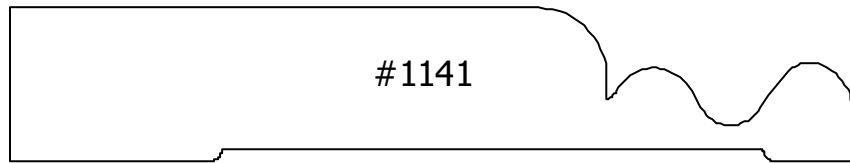

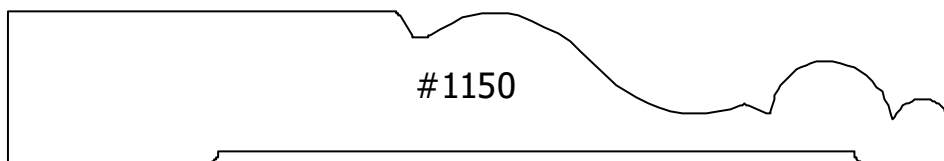
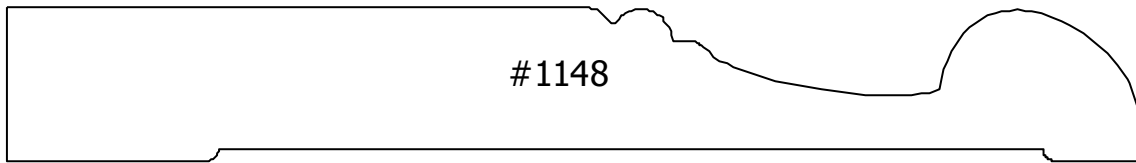
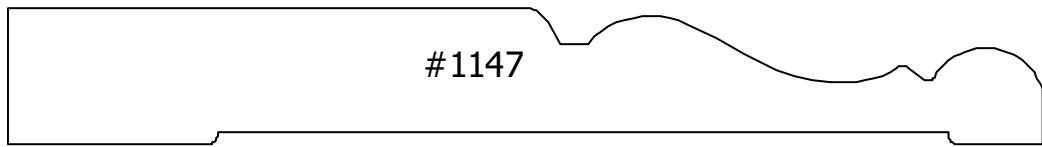
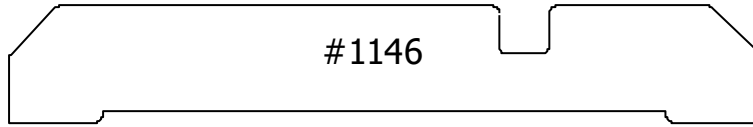

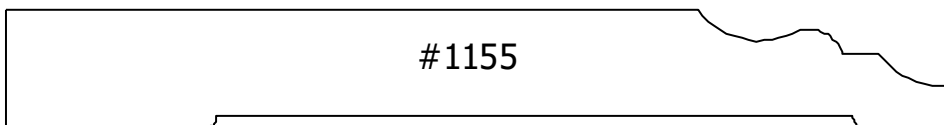
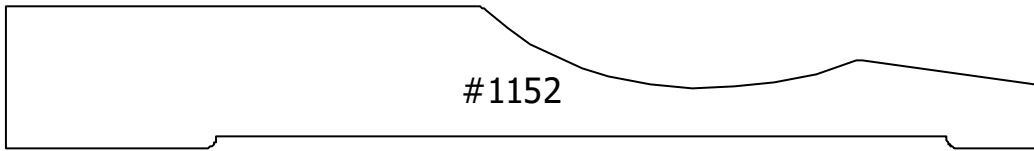
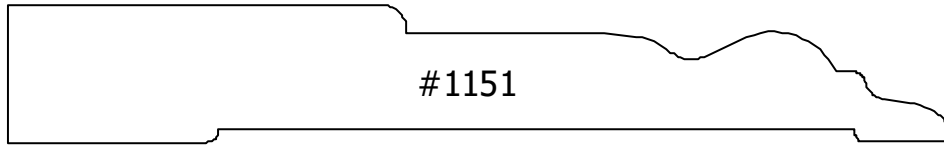

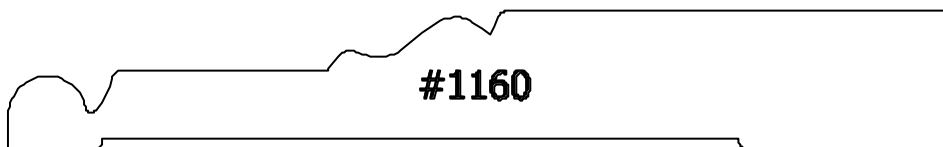
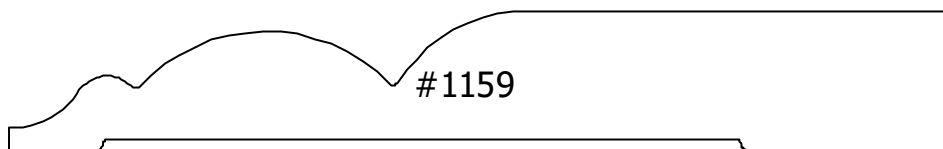
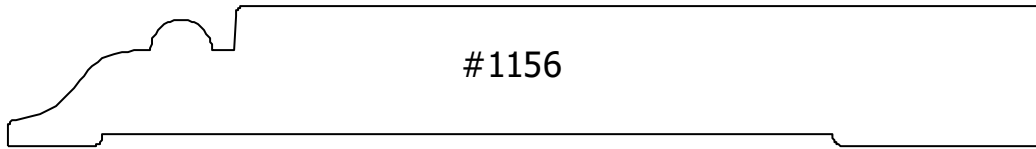

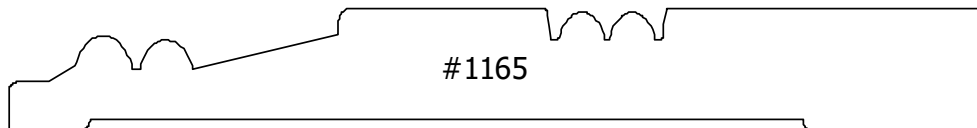
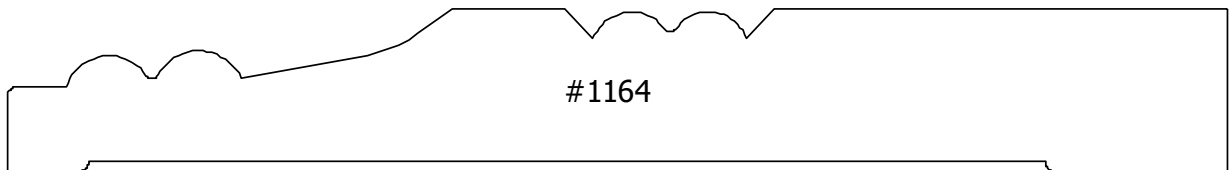
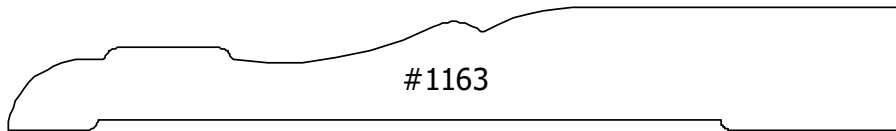
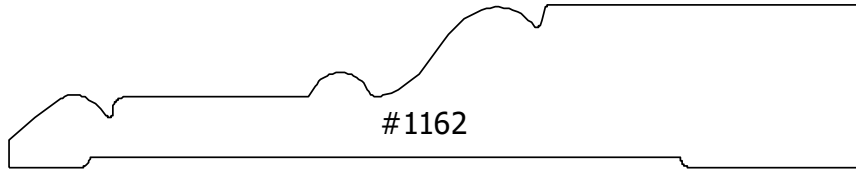

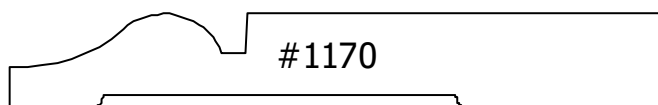
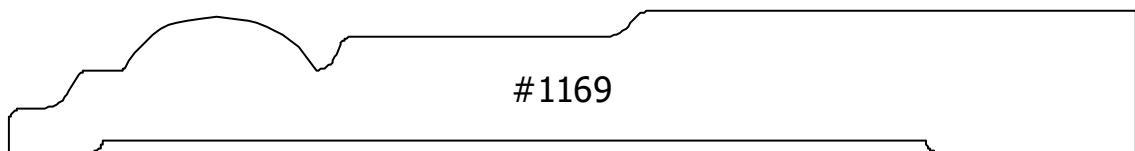
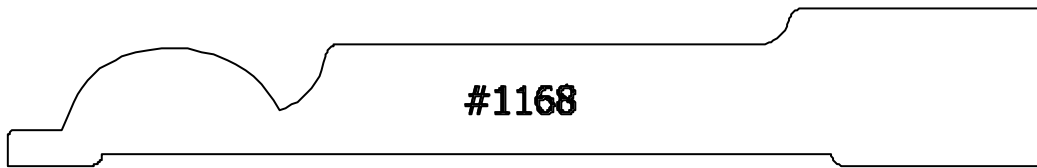
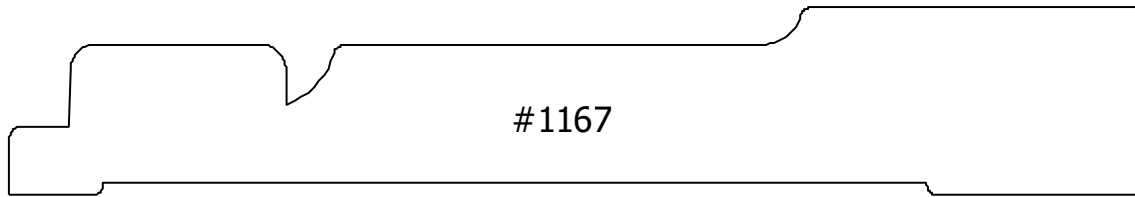
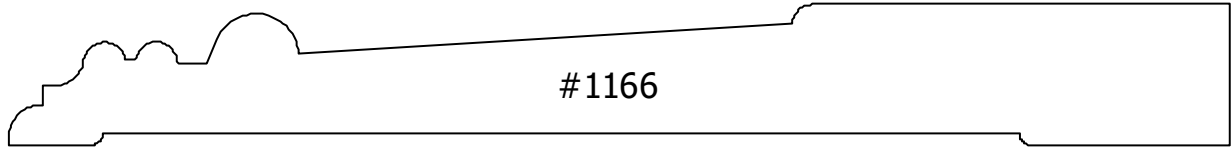

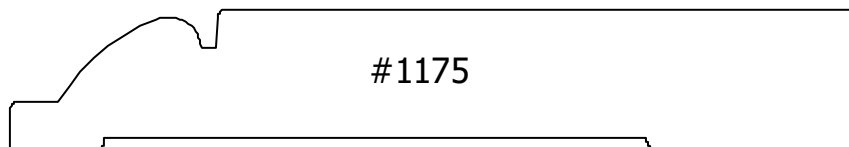
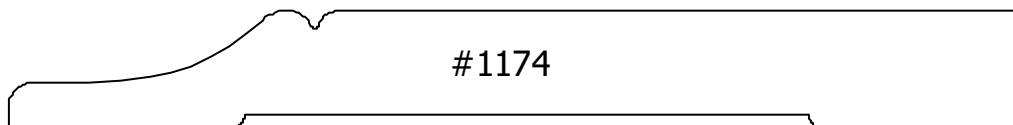
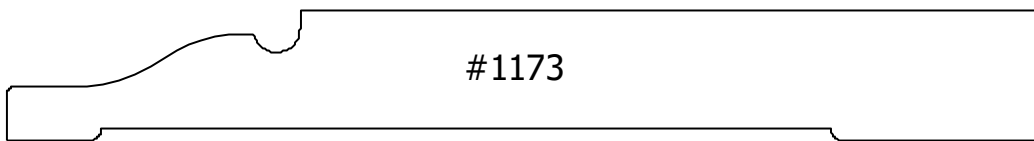

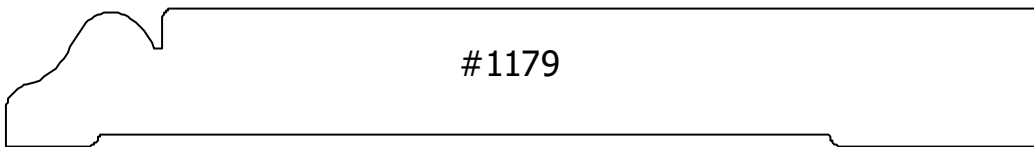
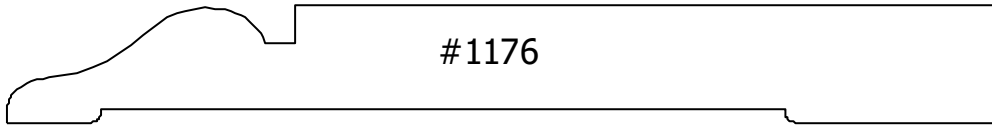



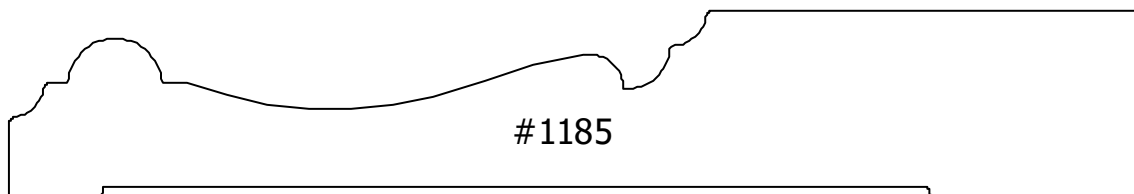
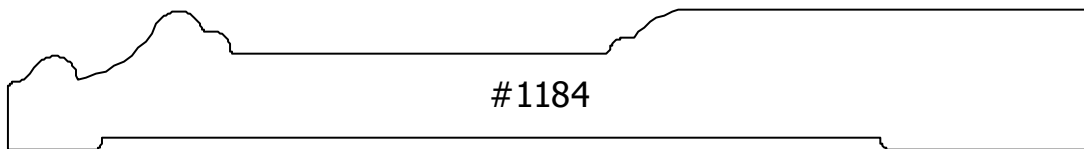
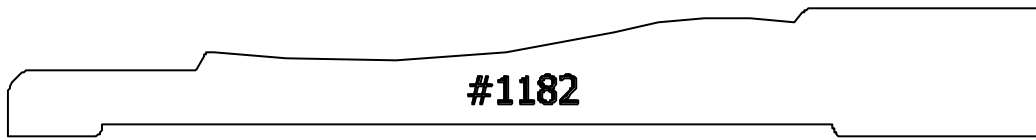
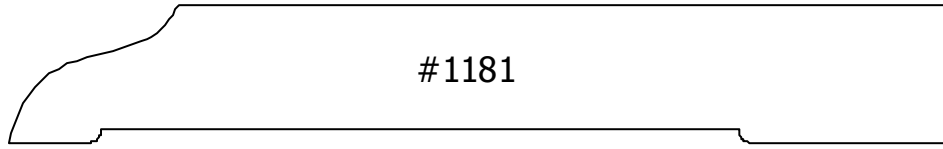

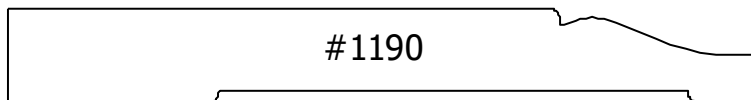
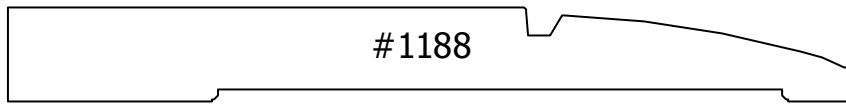
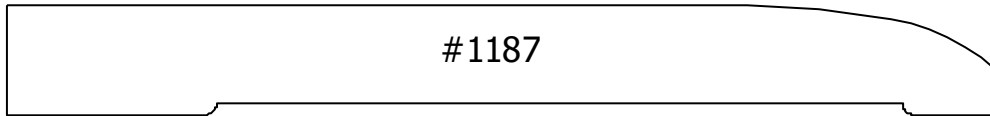
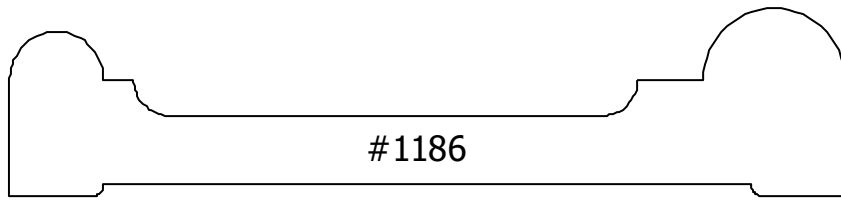

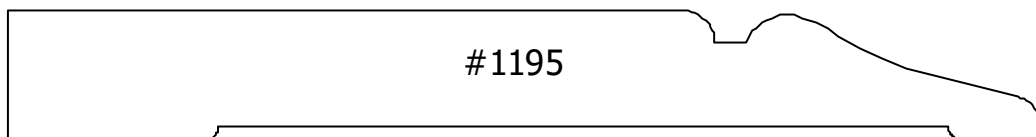
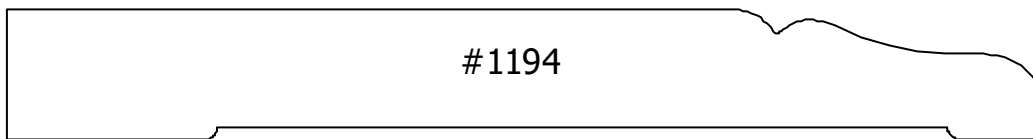
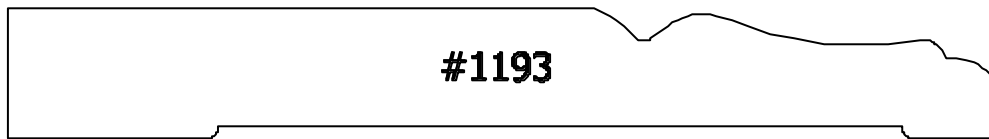
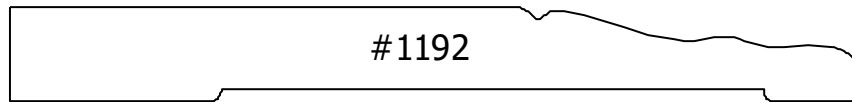
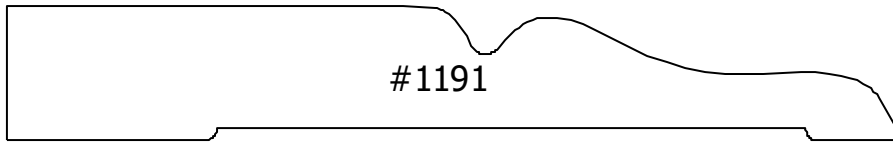

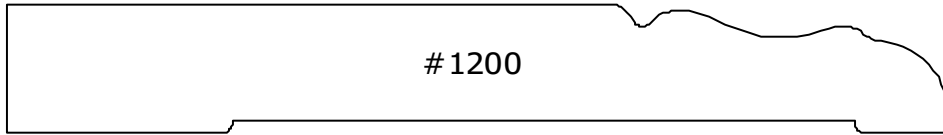
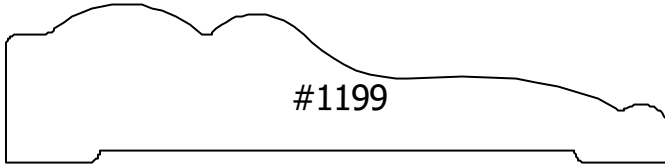
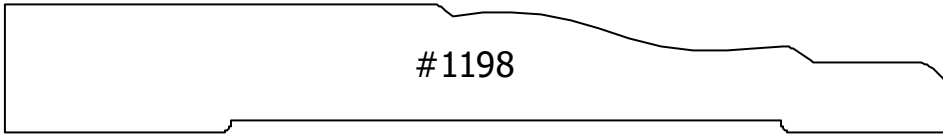
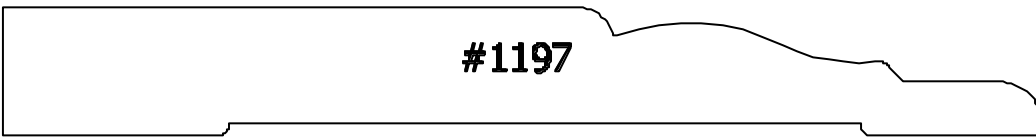
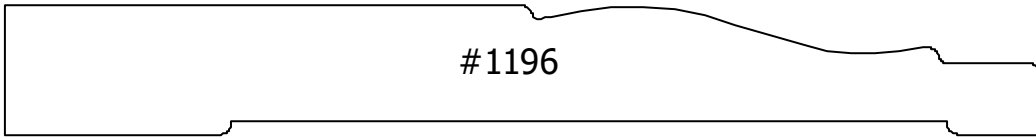

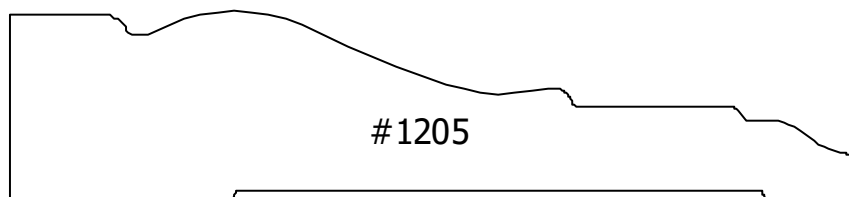
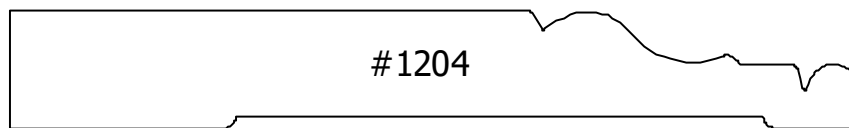
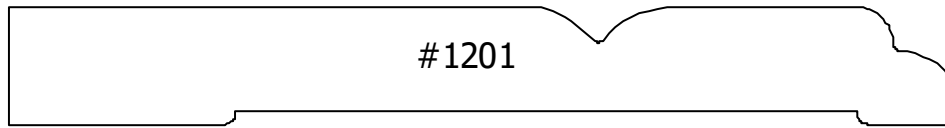

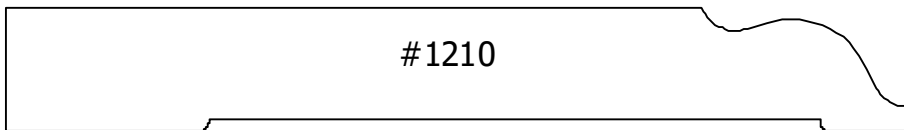
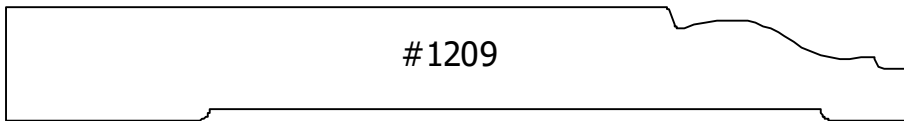
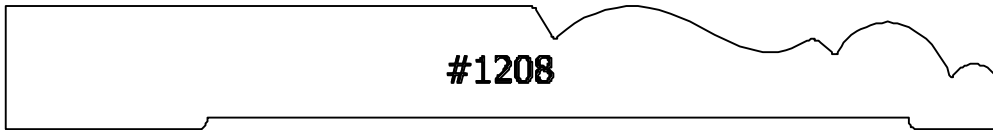
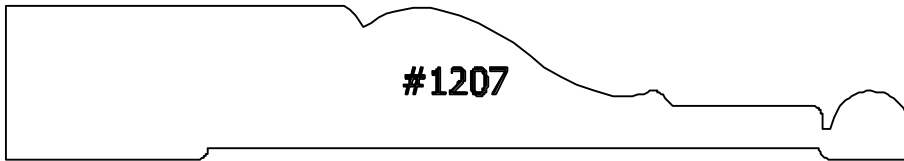

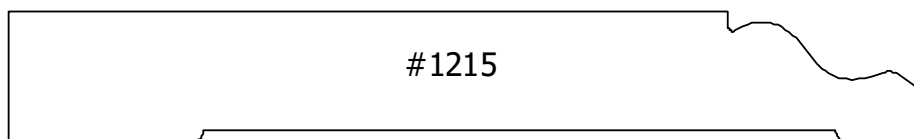
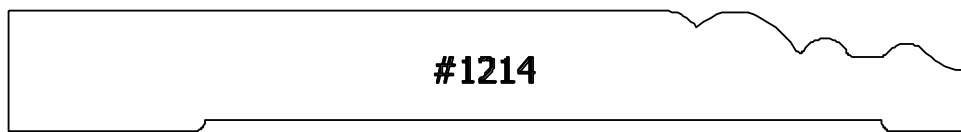
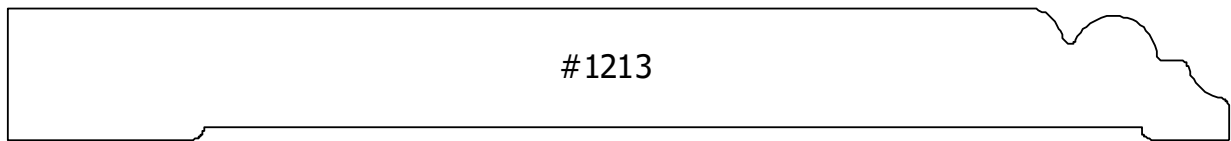
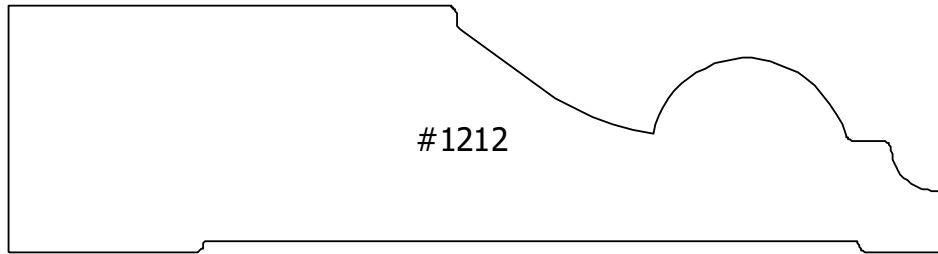
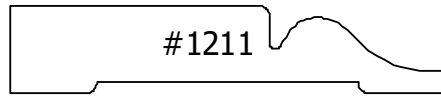

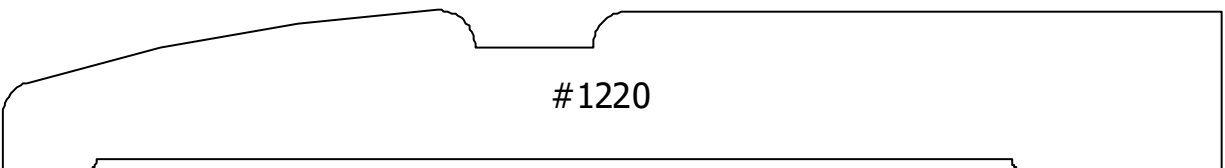
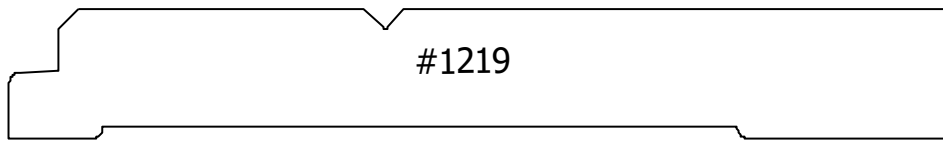
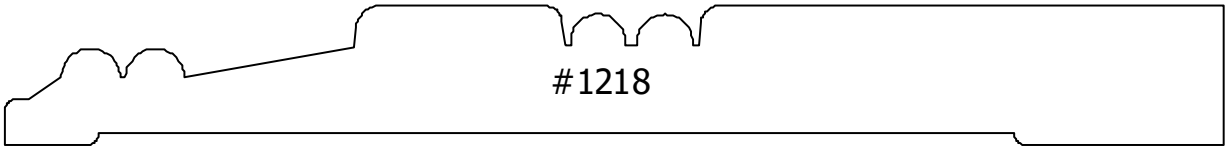
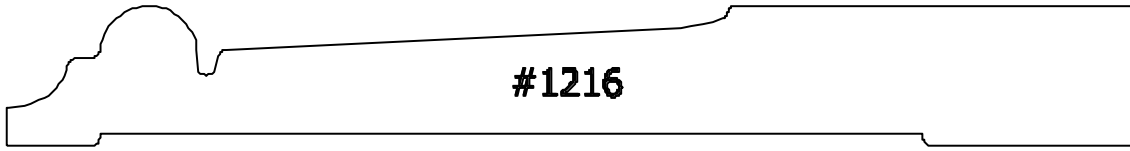



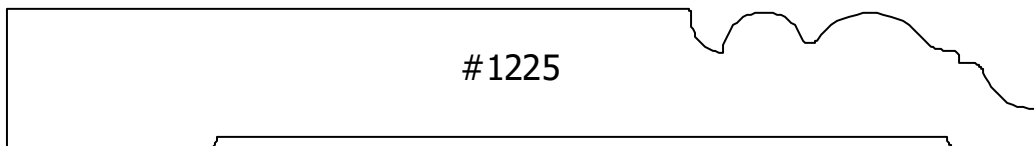
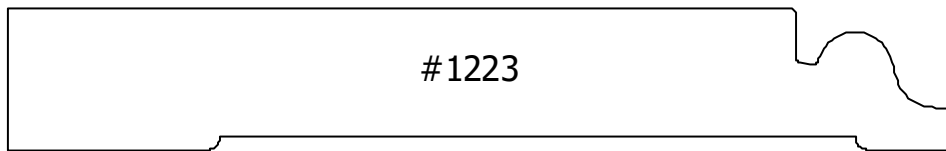
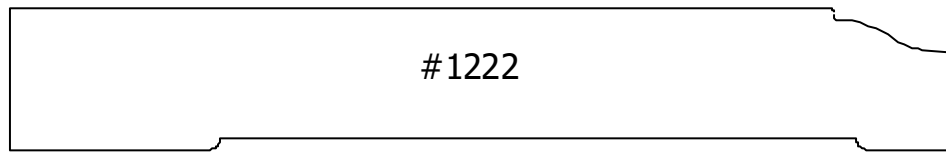
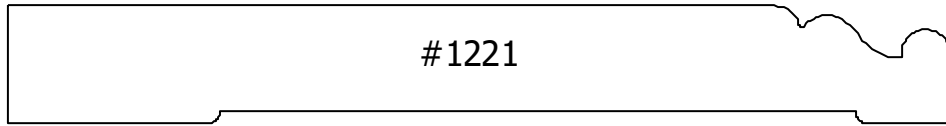

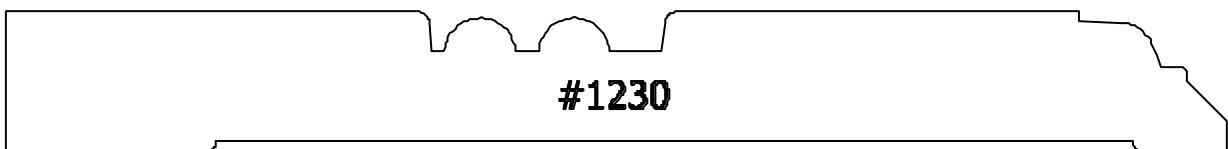
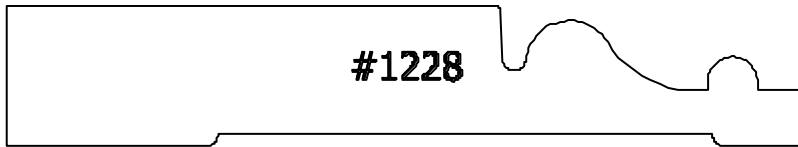
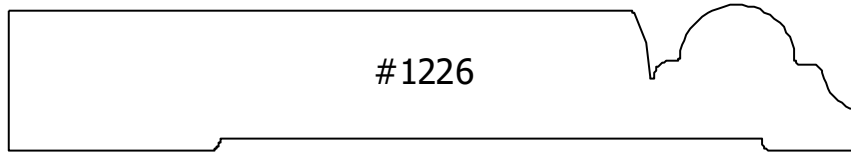

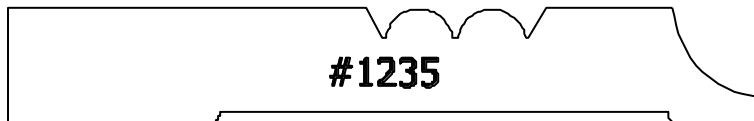
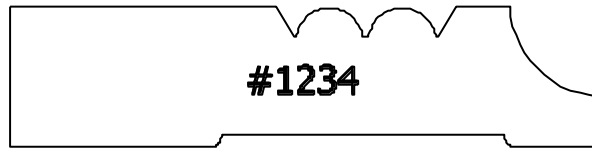
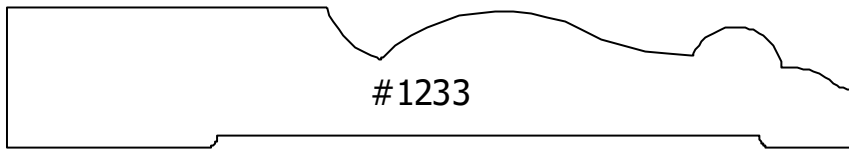
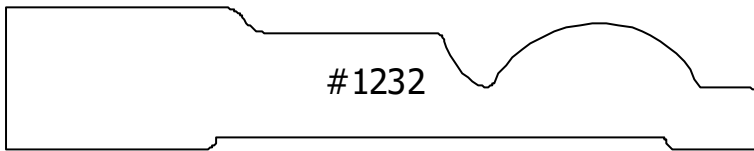
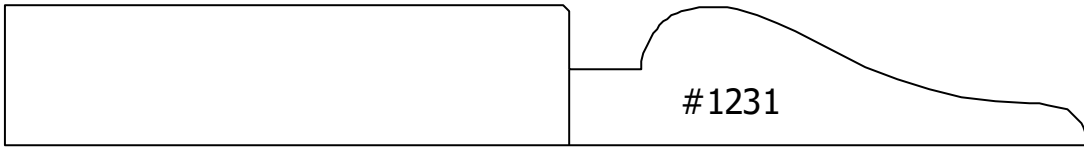

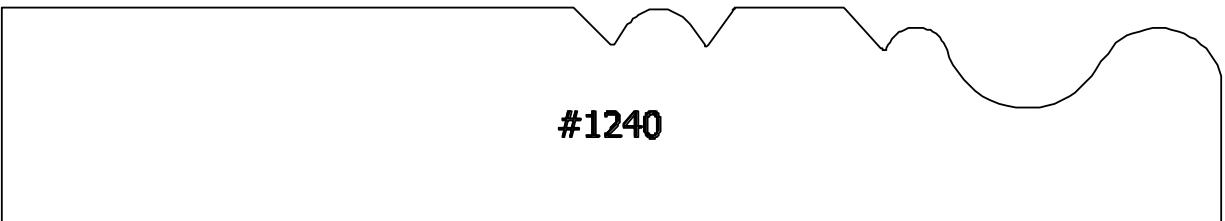
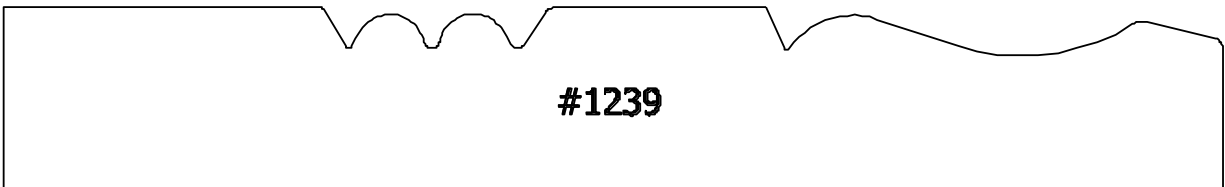
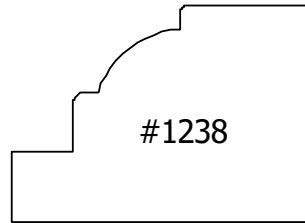
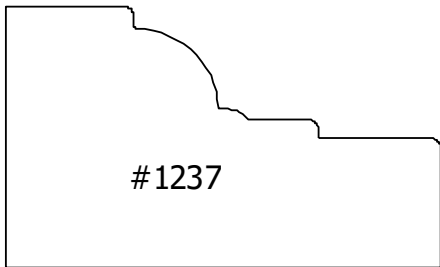
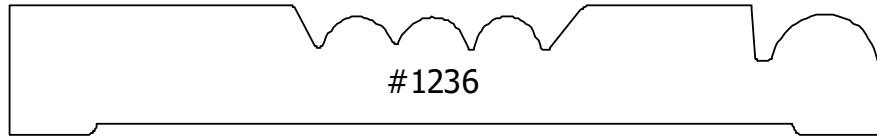

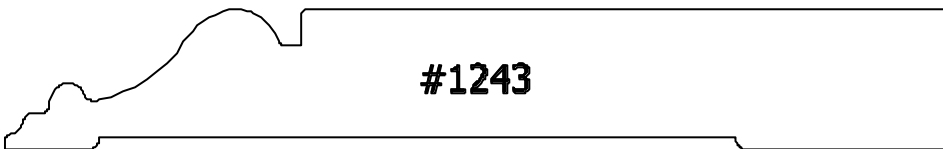

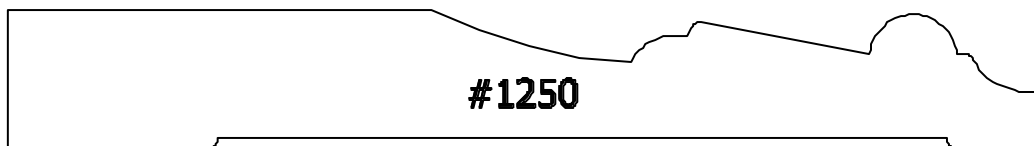
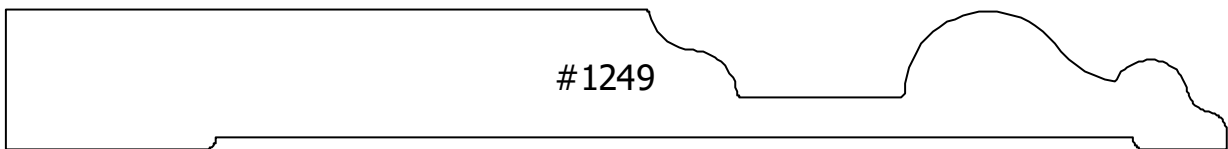
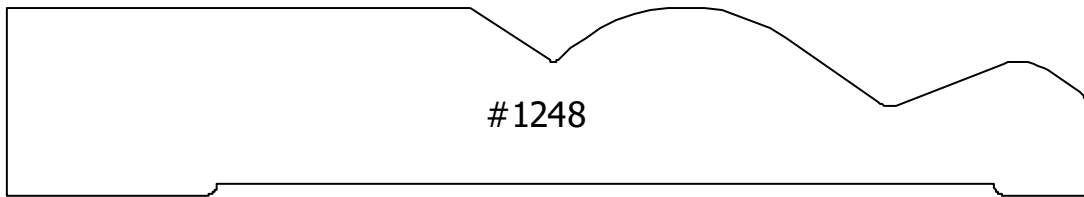

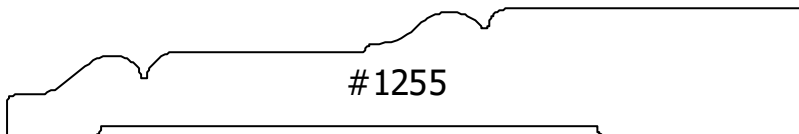
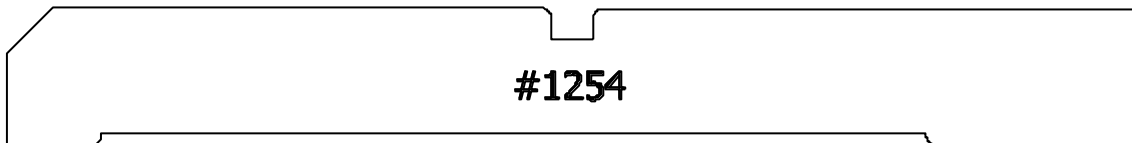
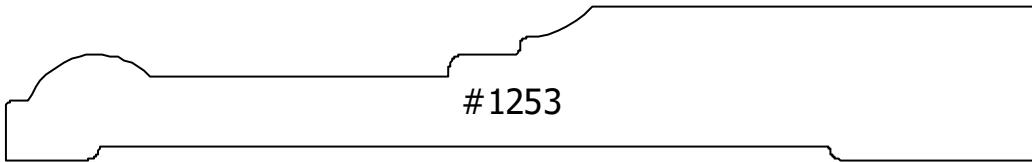
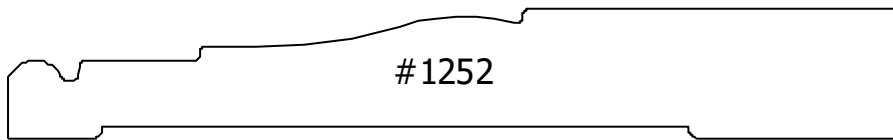

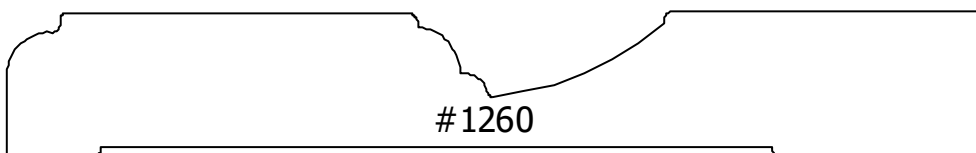
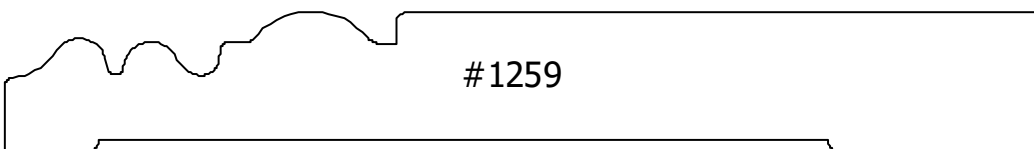
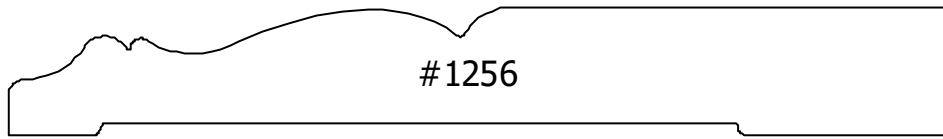



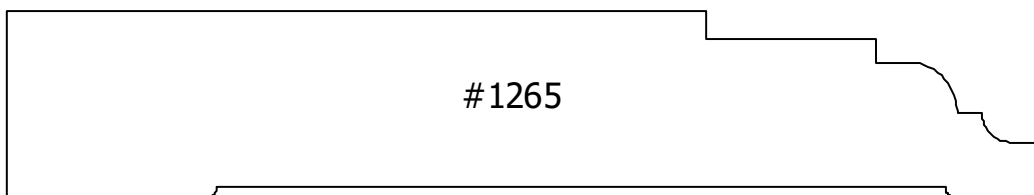
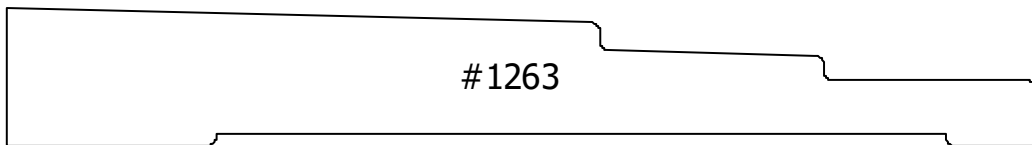

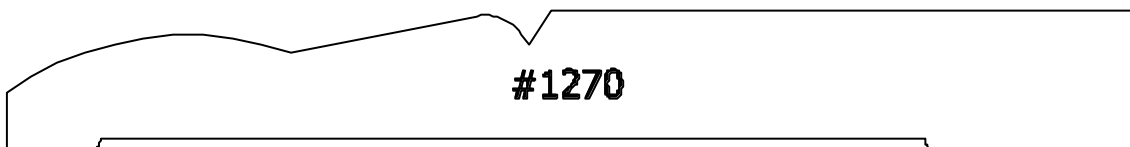
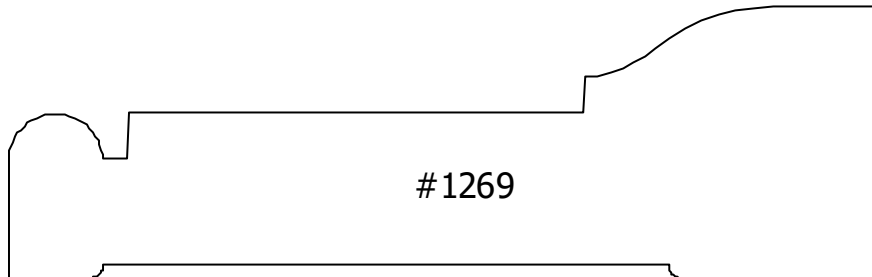
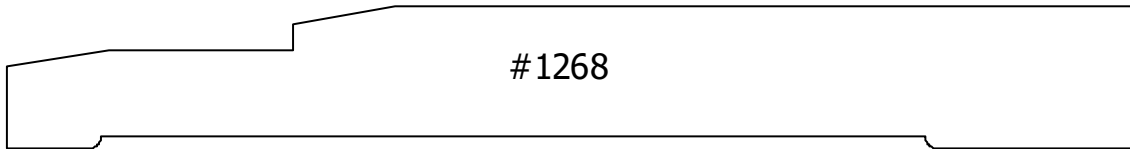
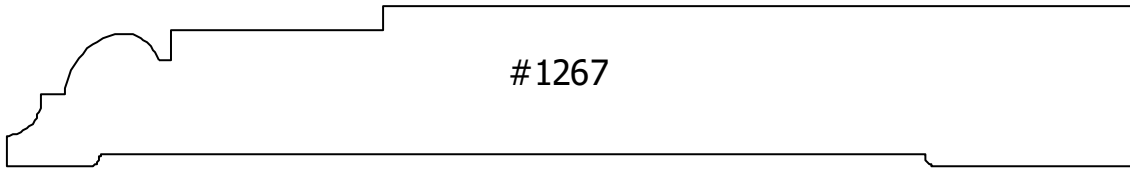
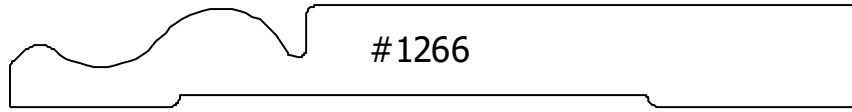

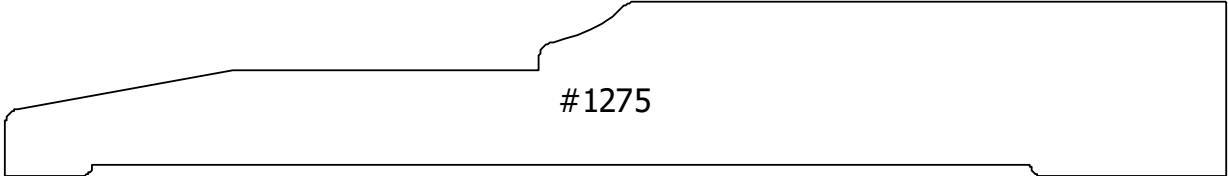
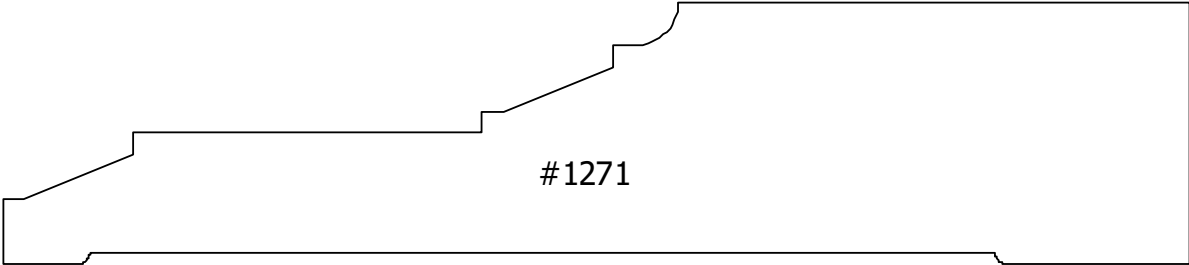

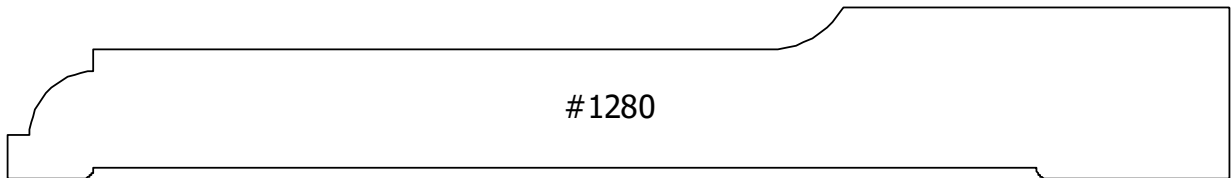
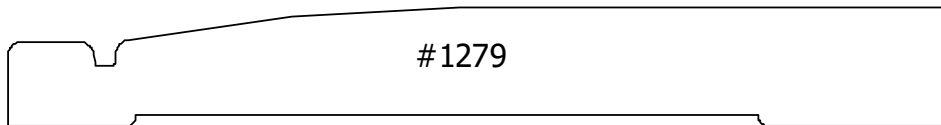
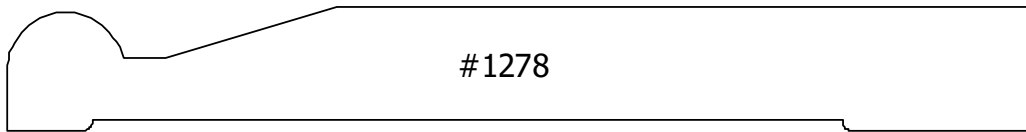

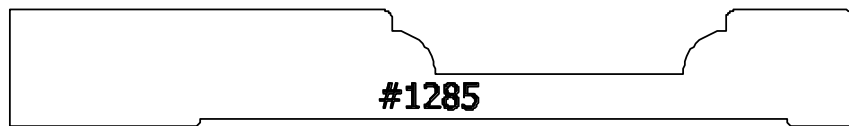
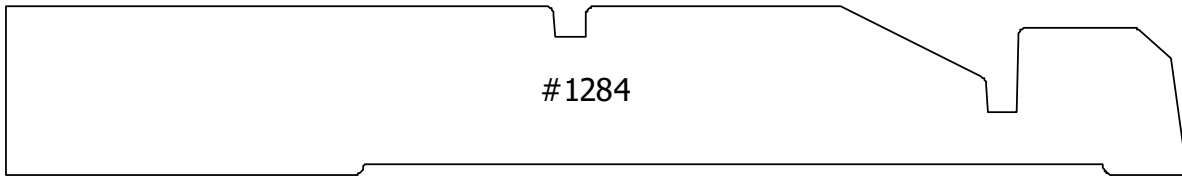
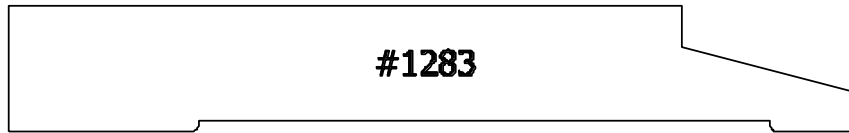
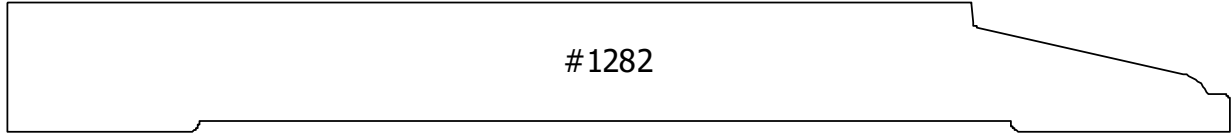

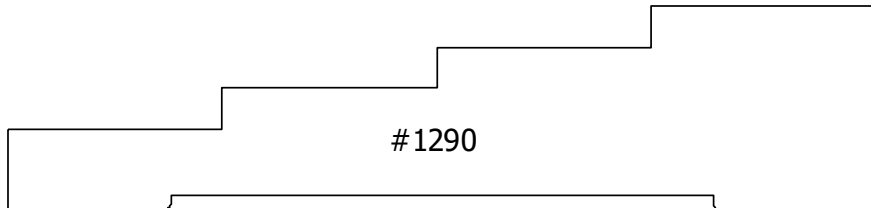
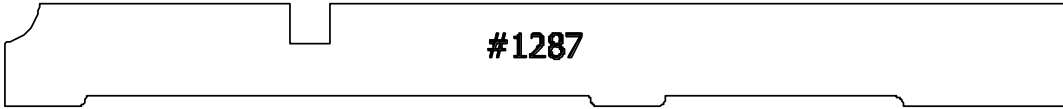
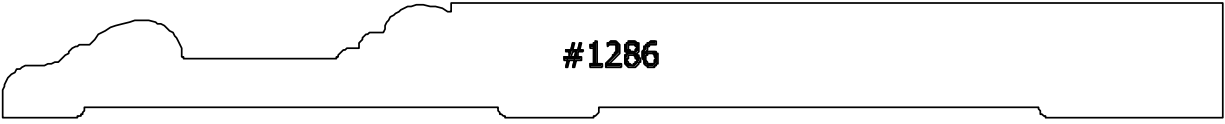

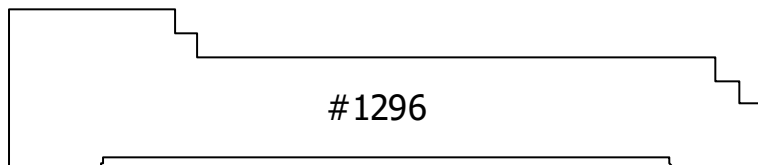
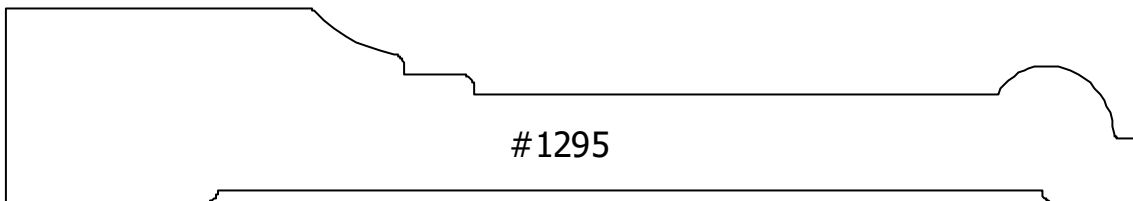
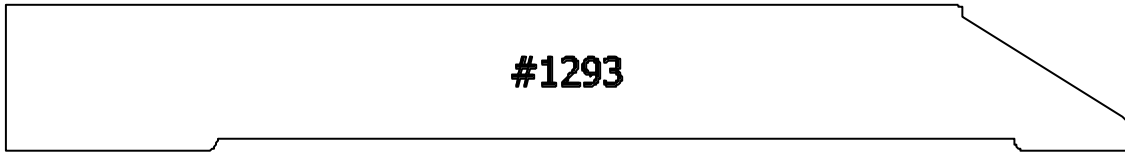
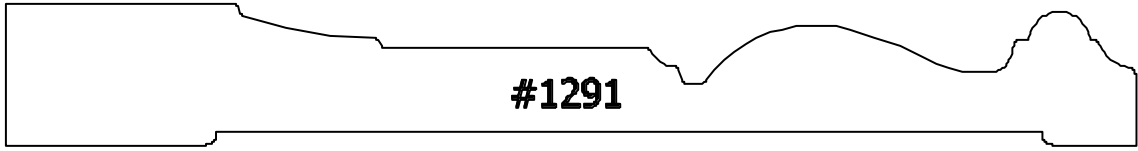

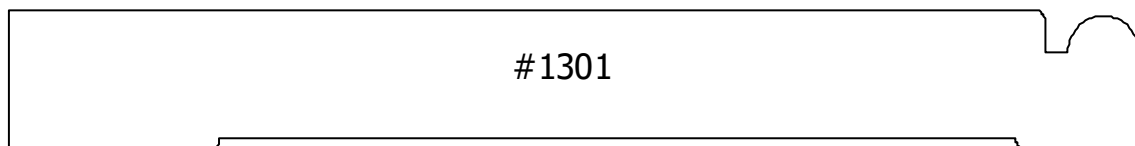
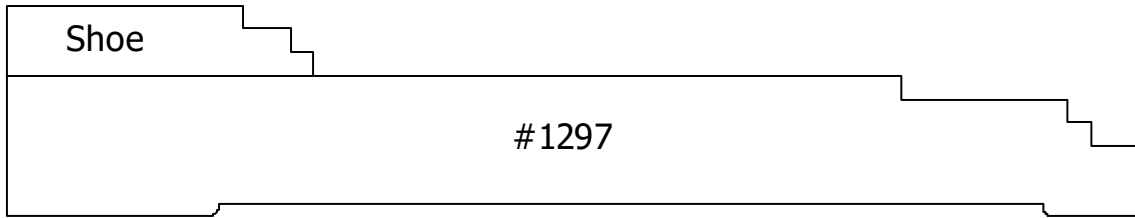



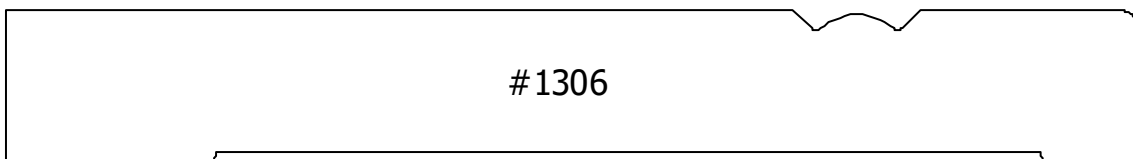
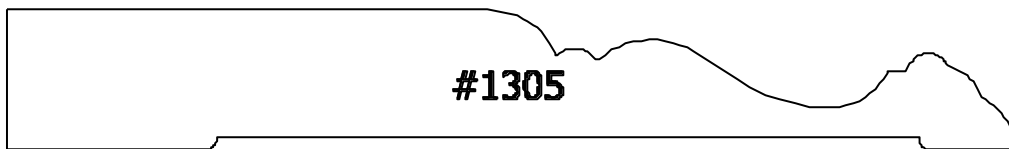
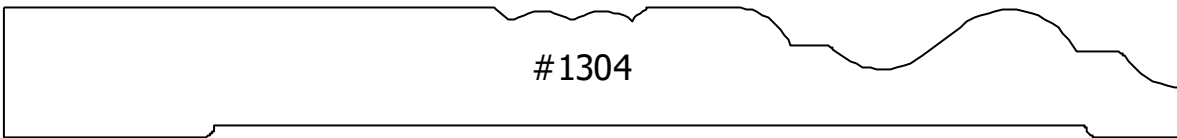
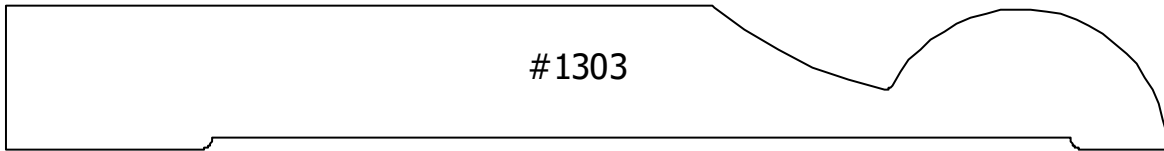
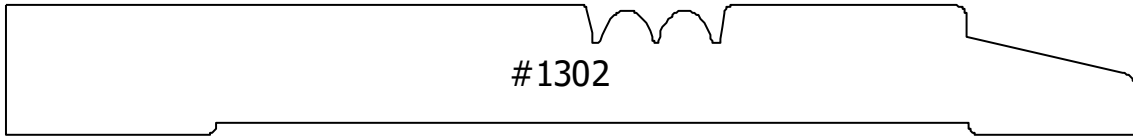

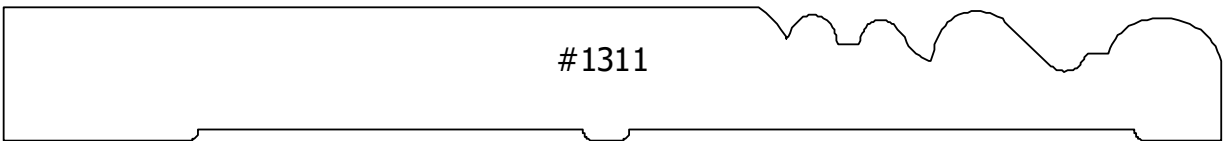
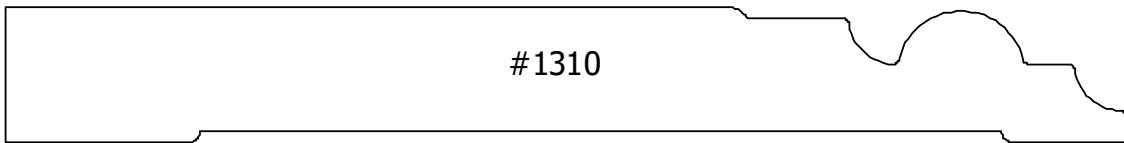
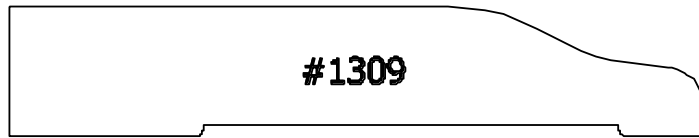
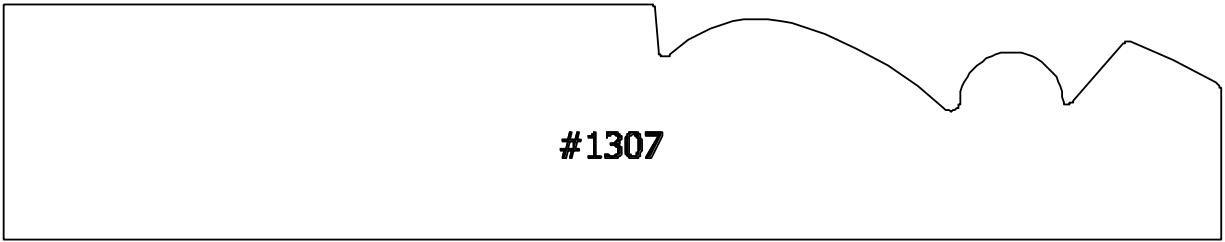

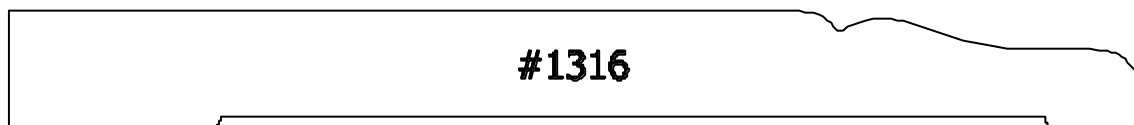
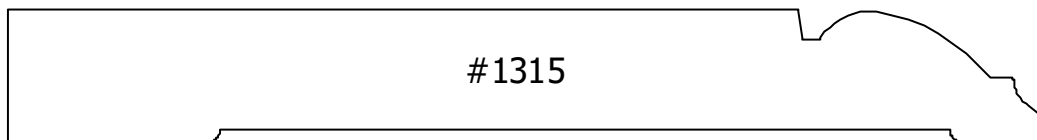
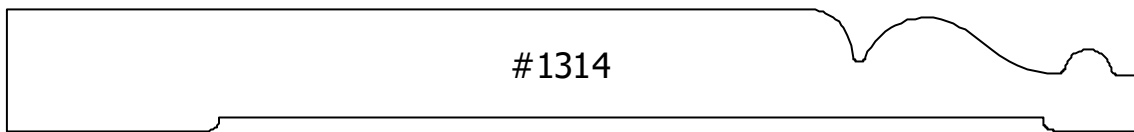
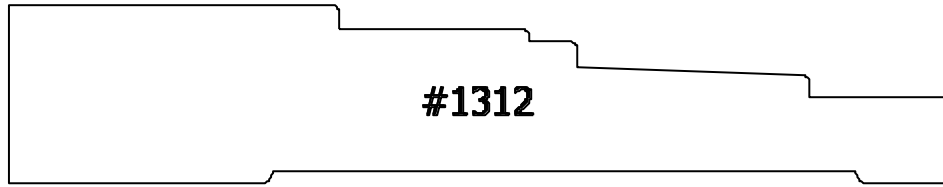

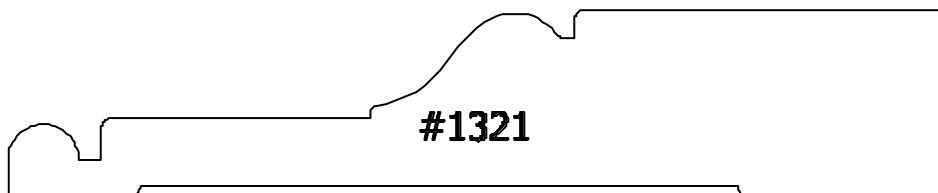
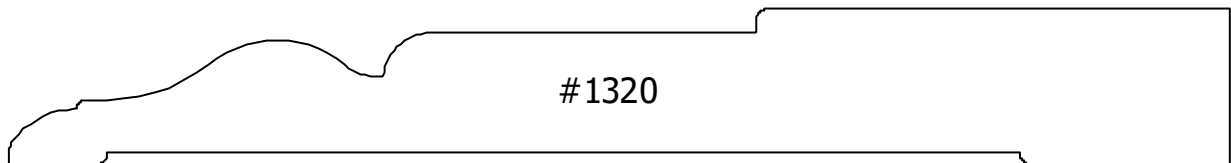
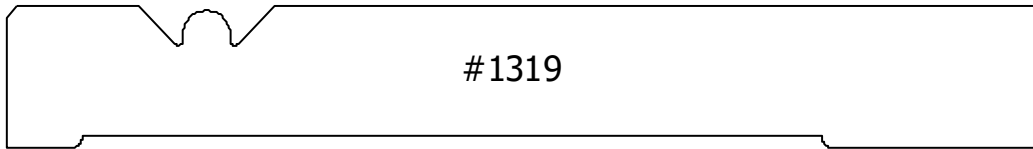
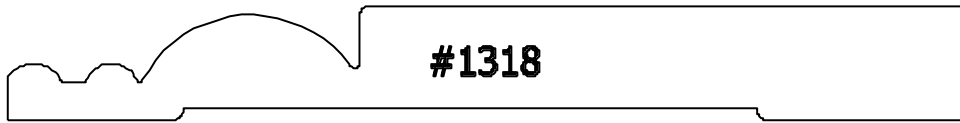

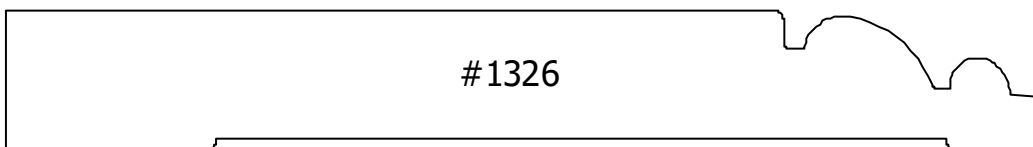
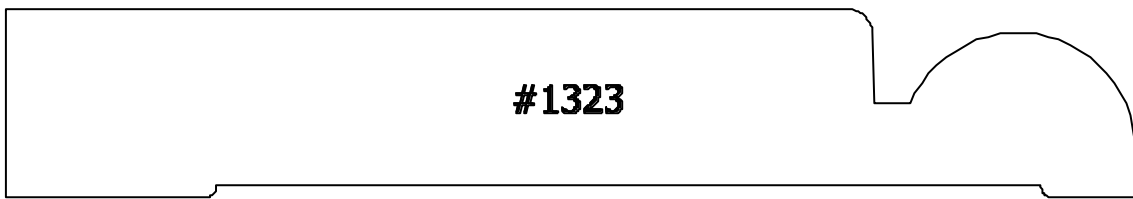

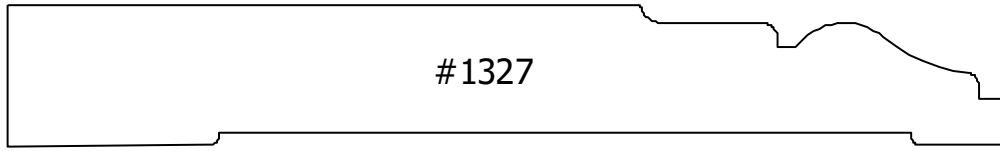

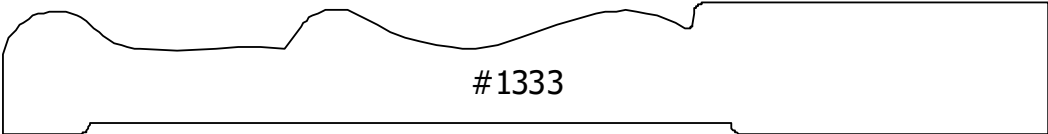

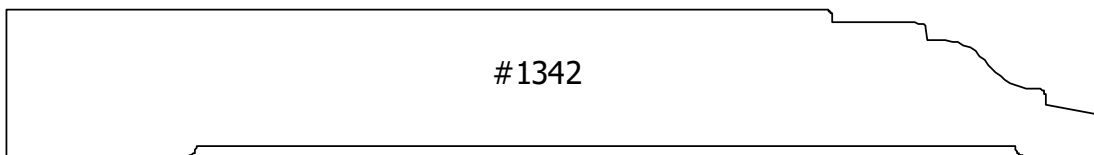
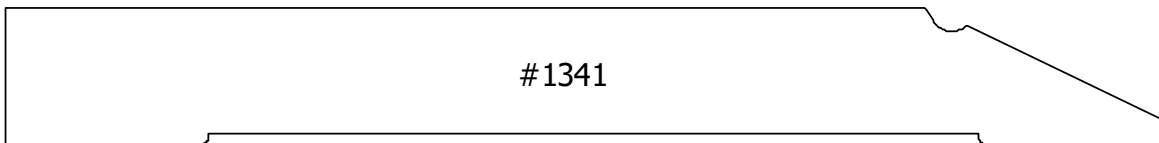
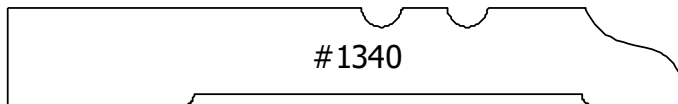
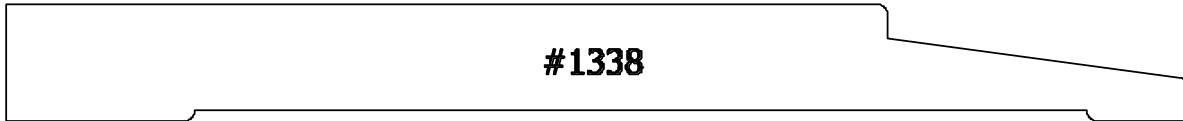
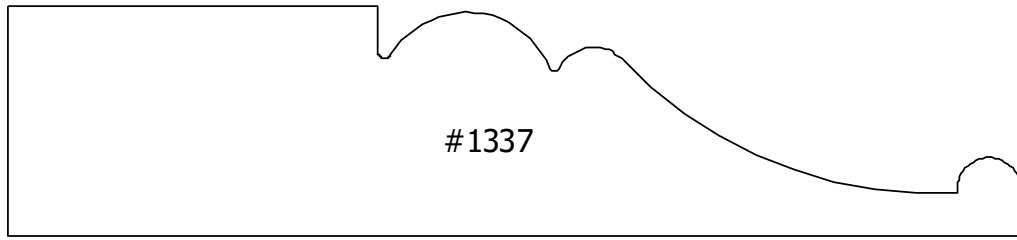



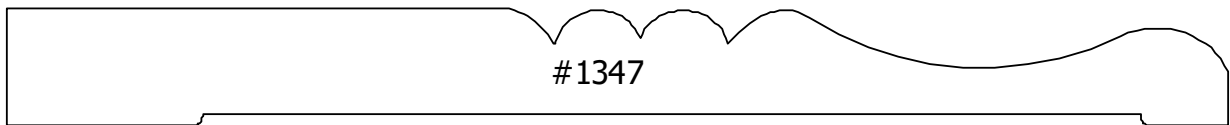
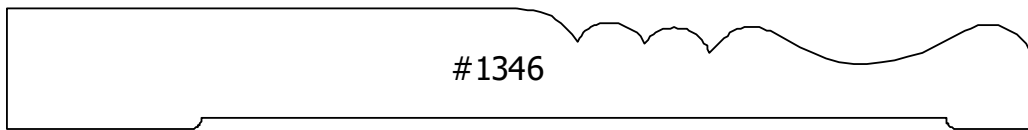
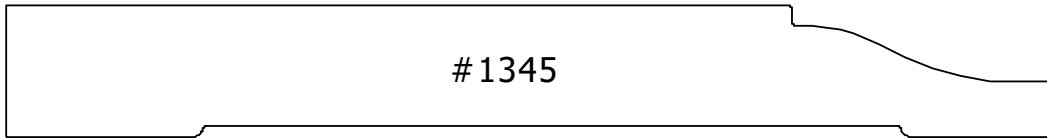
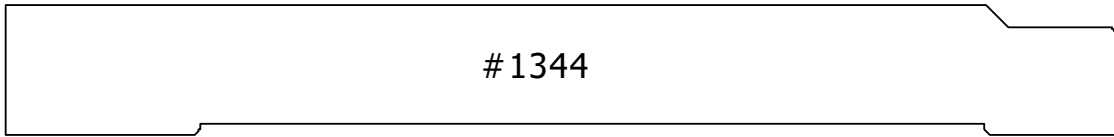
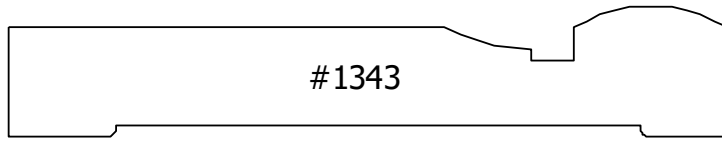

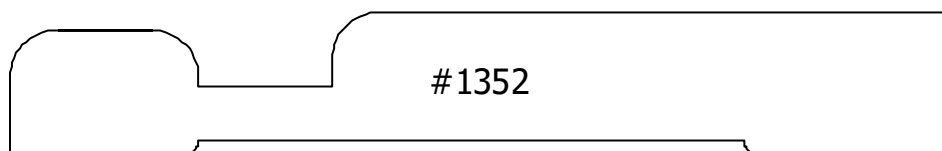

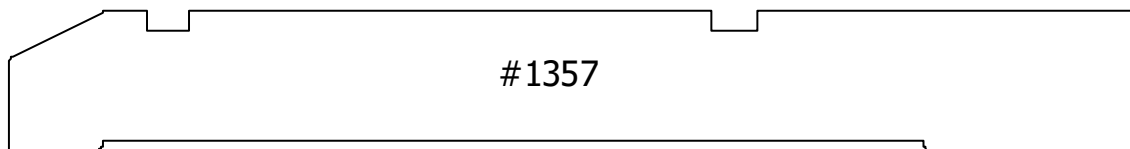
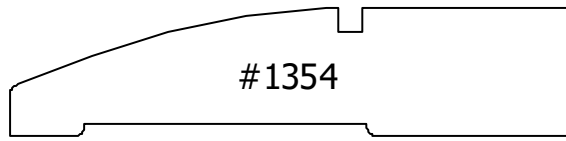
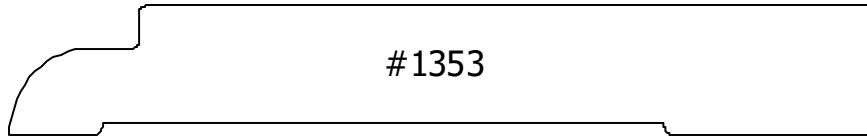

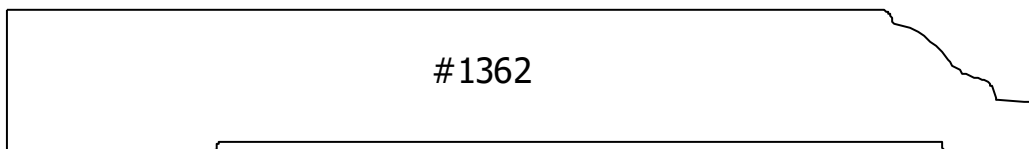
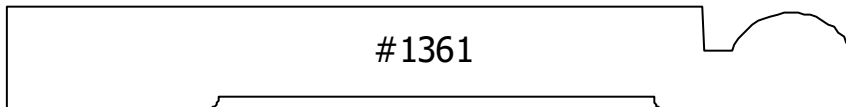
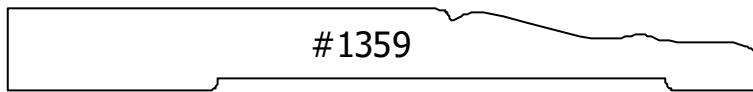
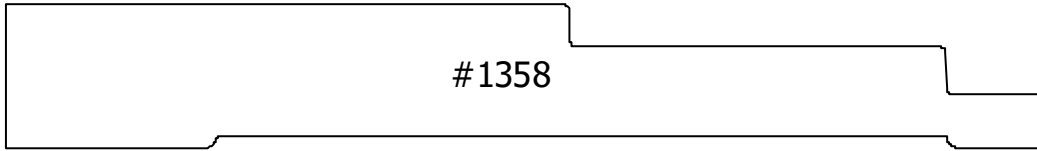

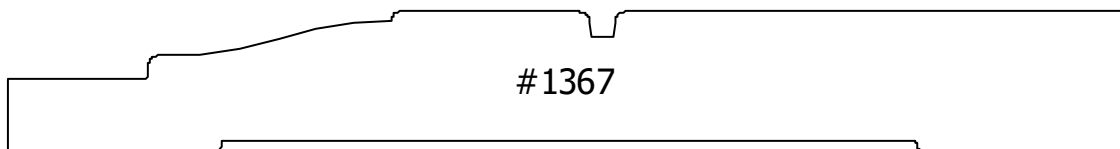
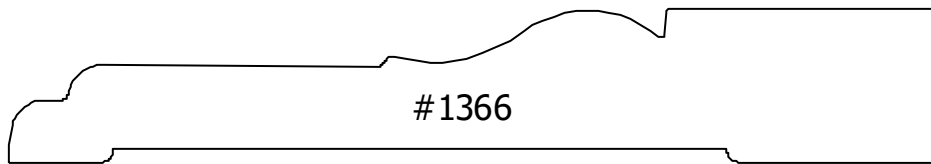
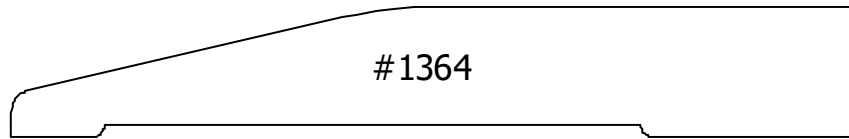
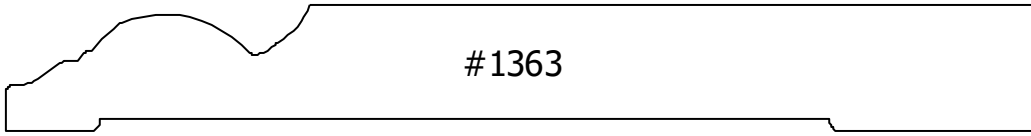

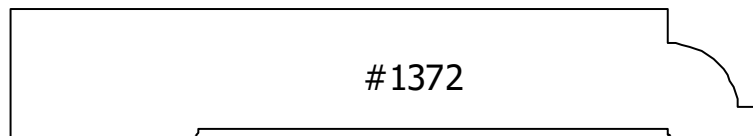
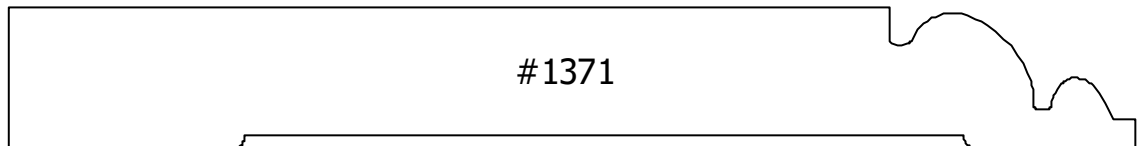
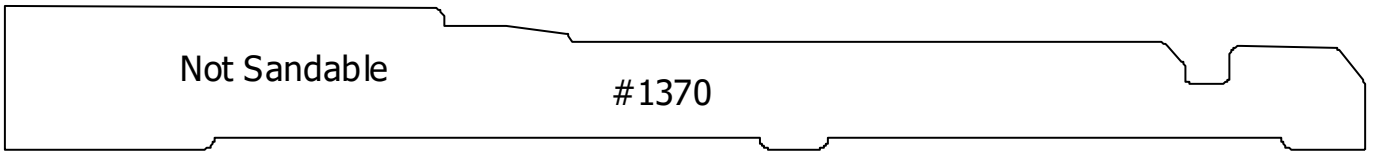

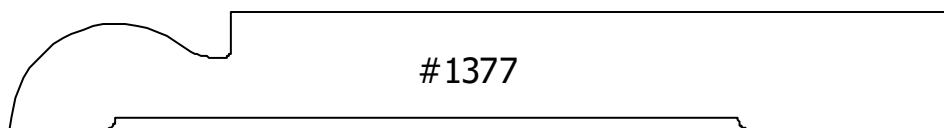
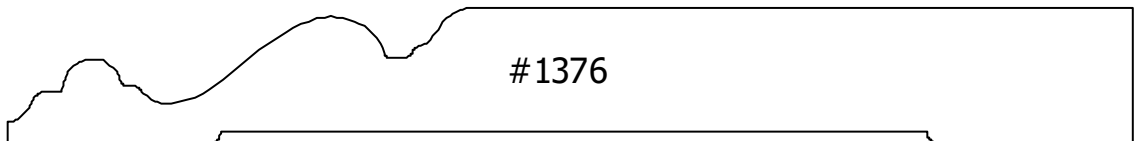
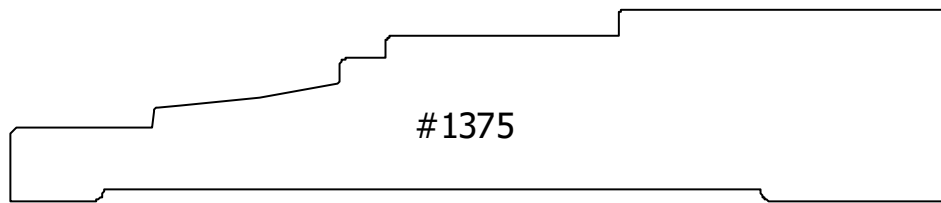

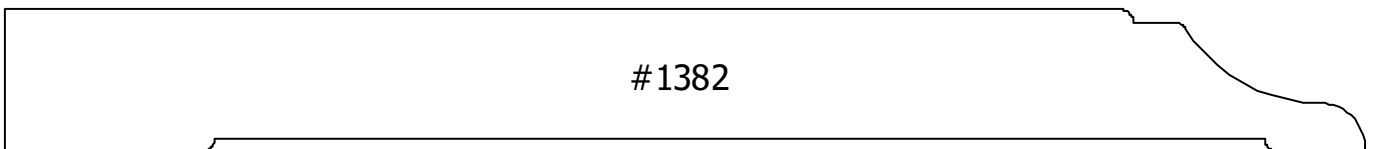
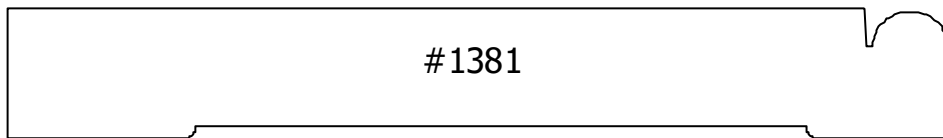
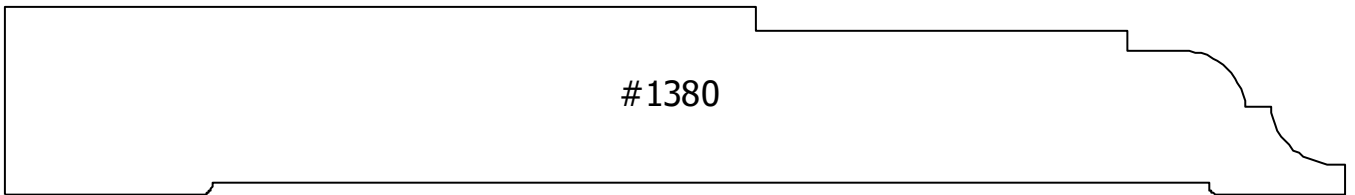
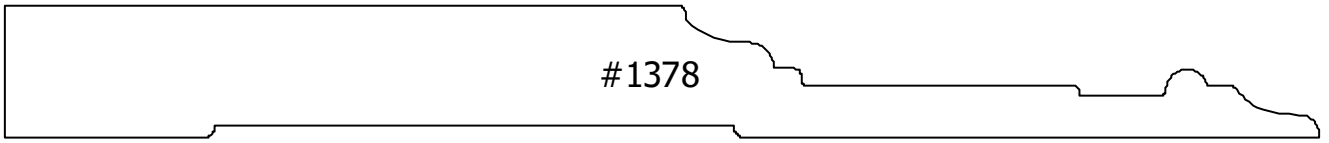



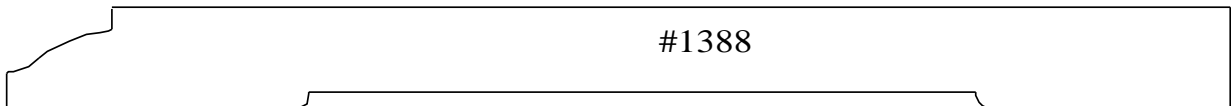
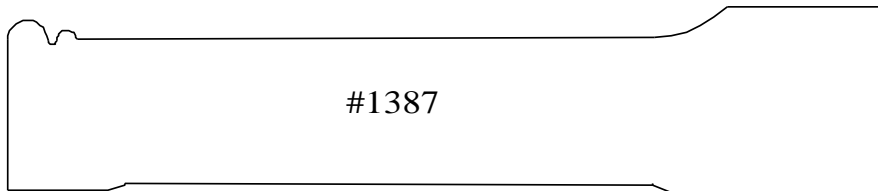
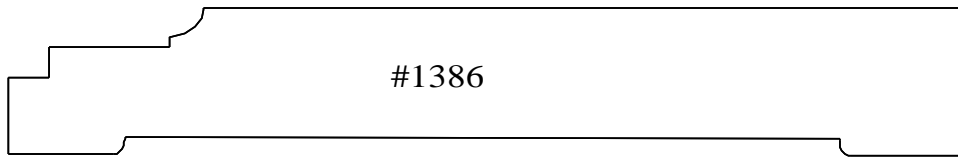
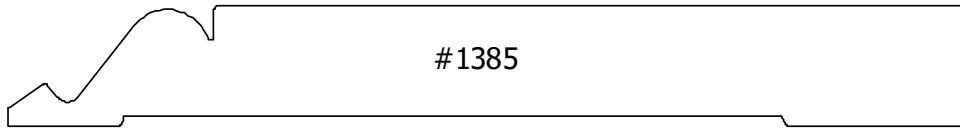
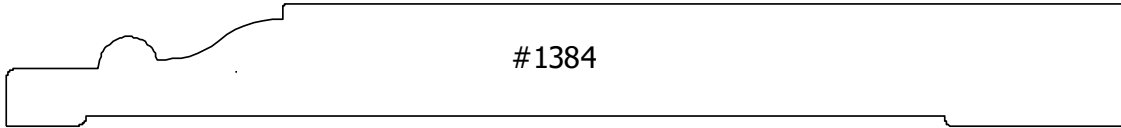
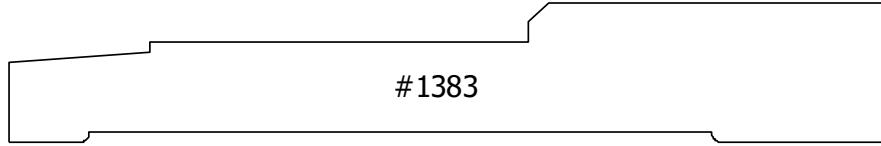

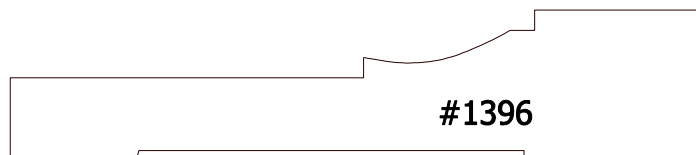
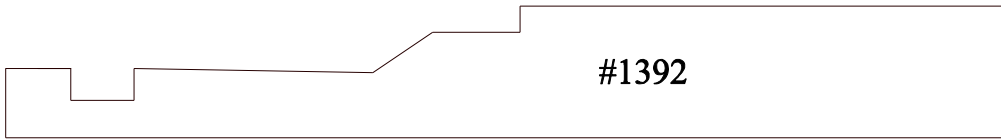
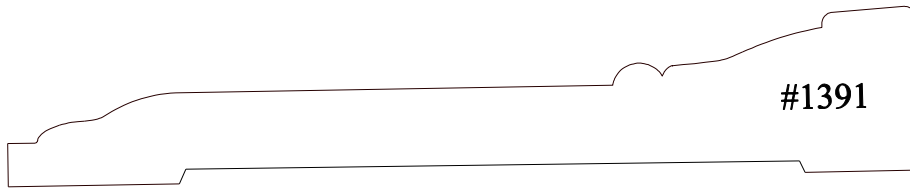
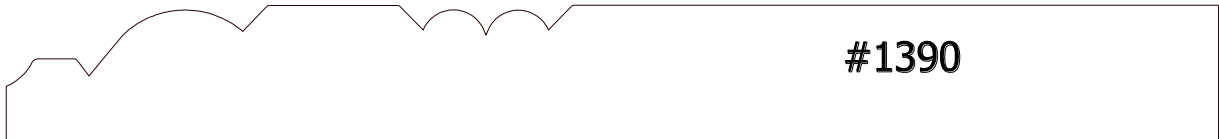
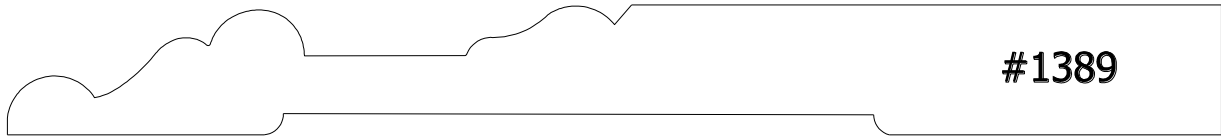







# 1397

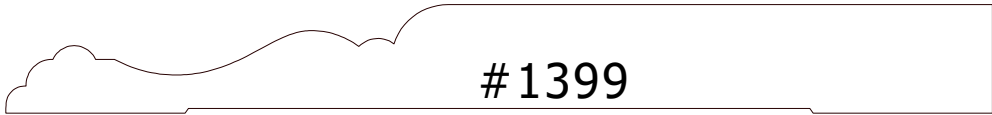

# 1398



# 1399



#1400

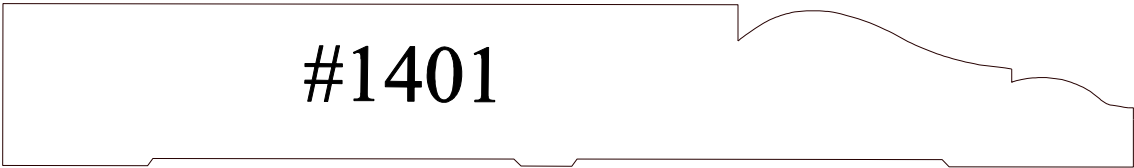

#1401

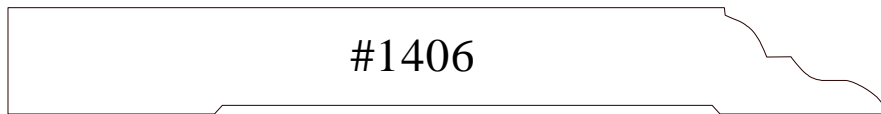
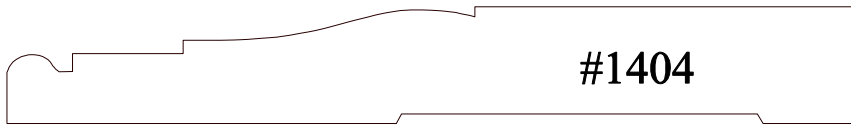

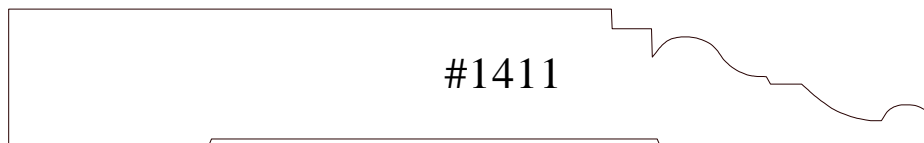
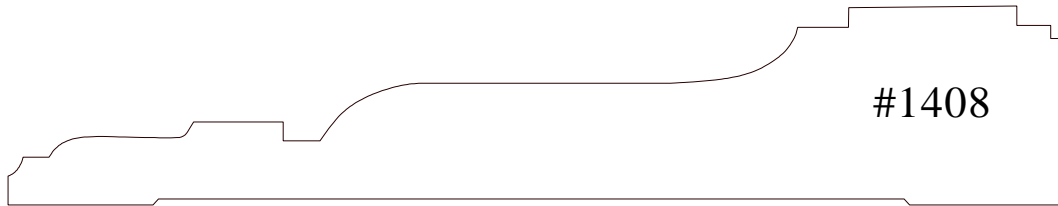
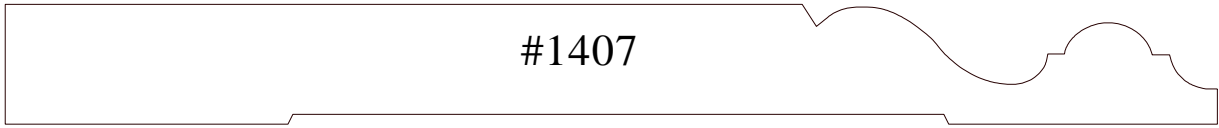

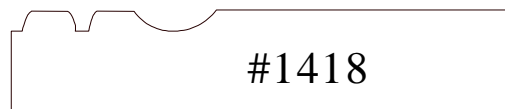
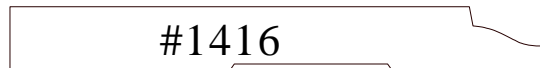
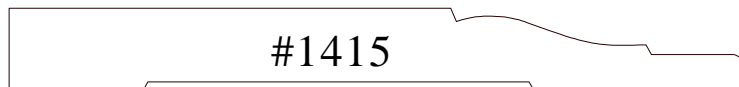
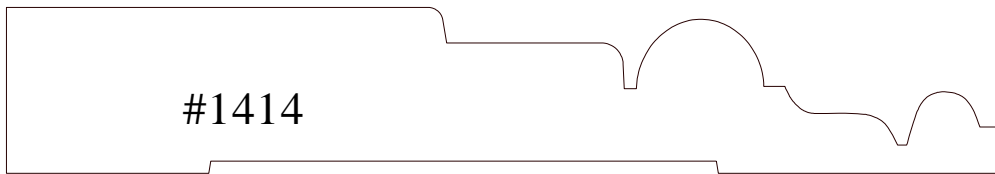
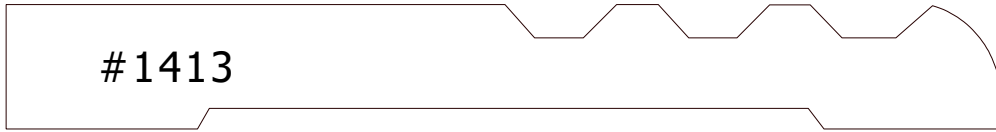

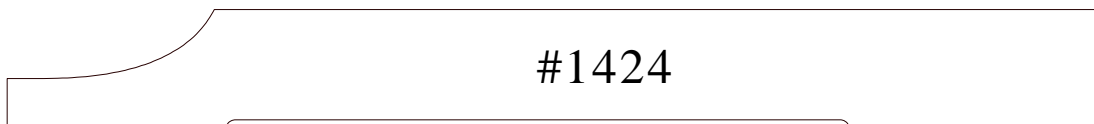
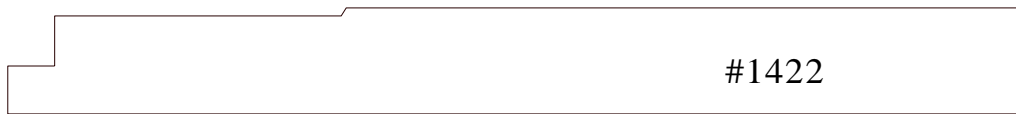
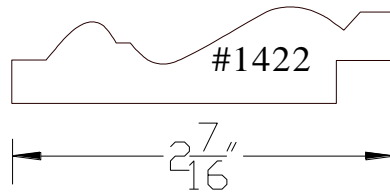

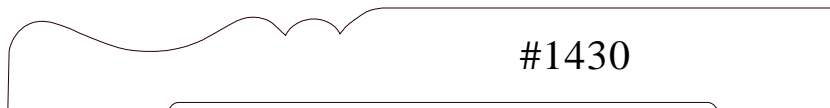
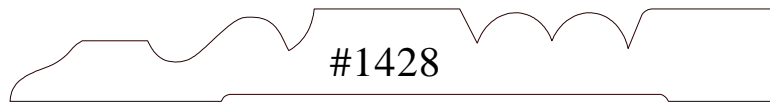
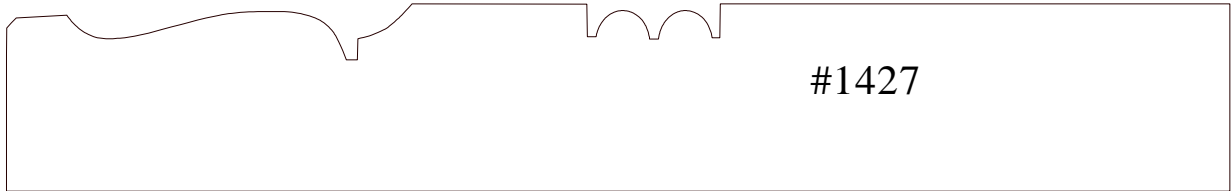



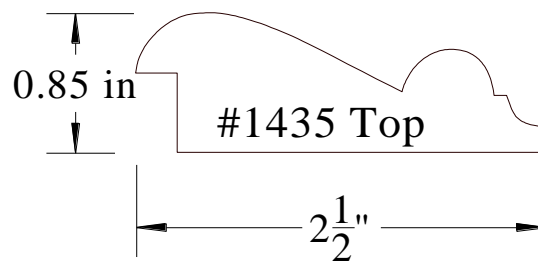
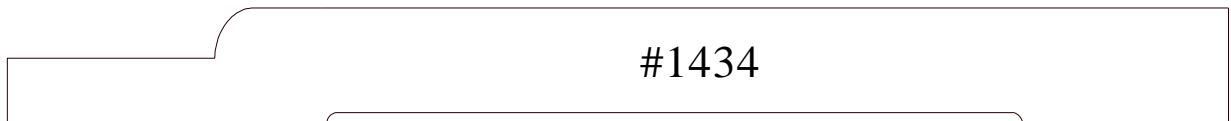
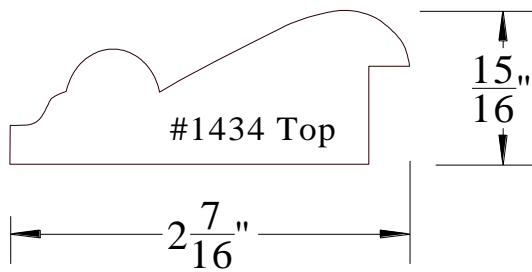
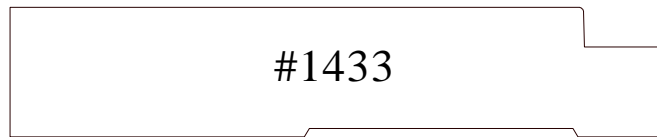

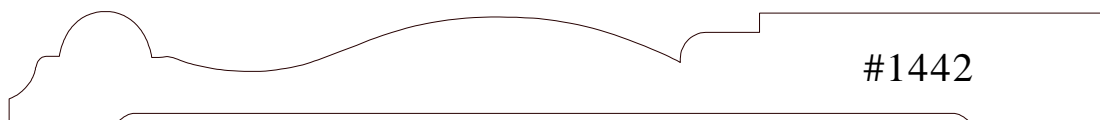
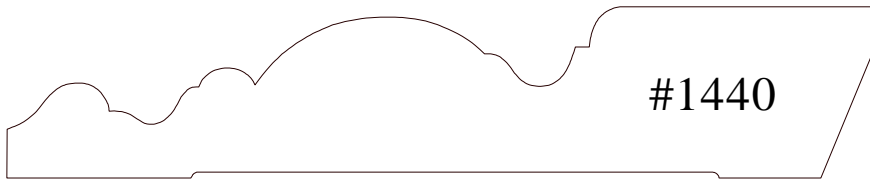
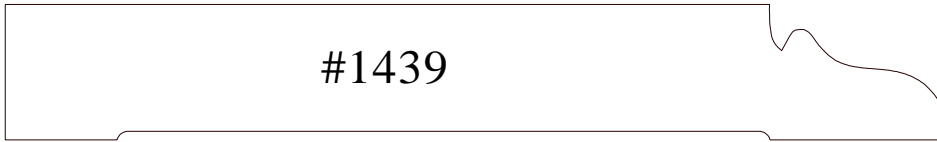
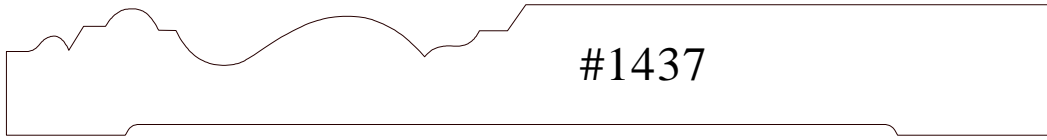

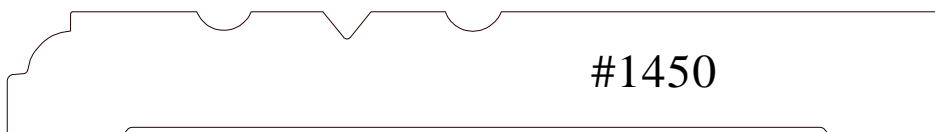
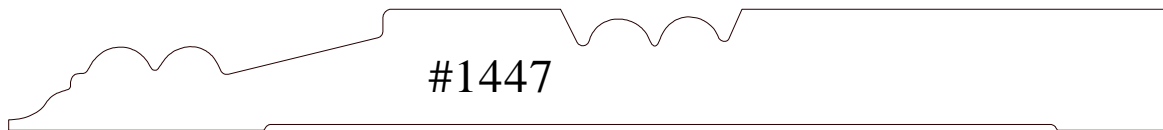
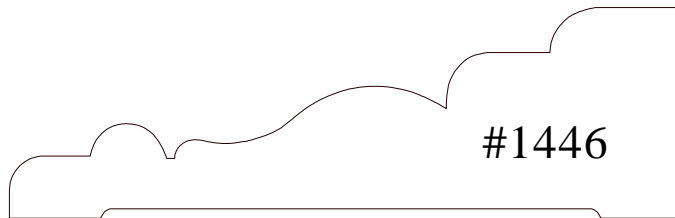
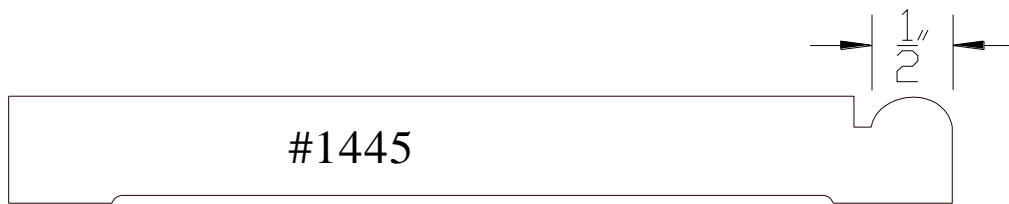

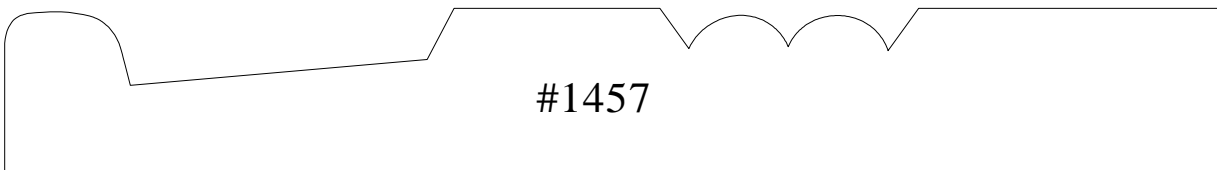
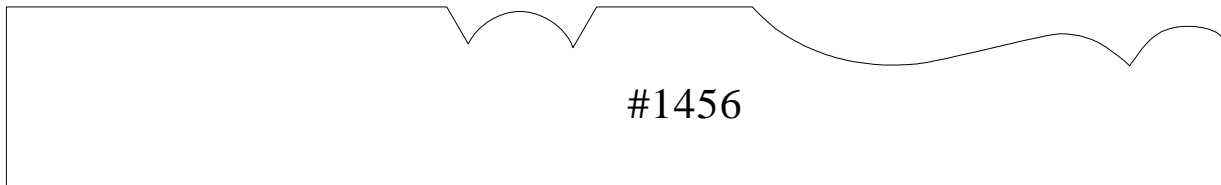
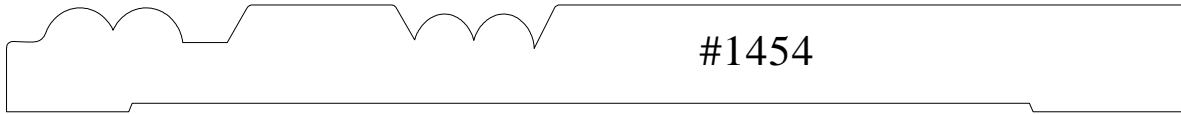
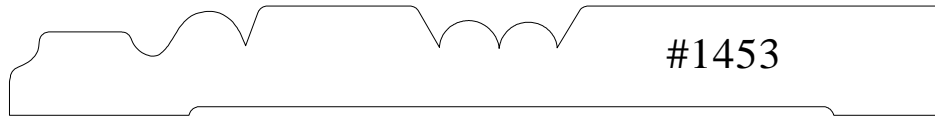
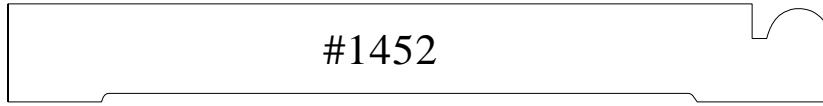
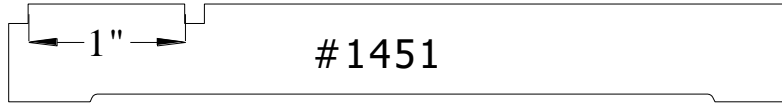

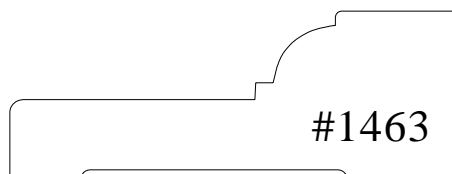
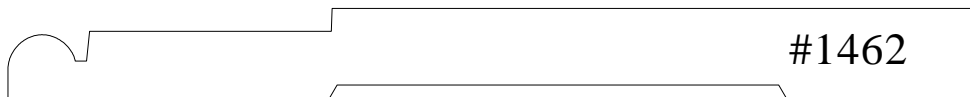
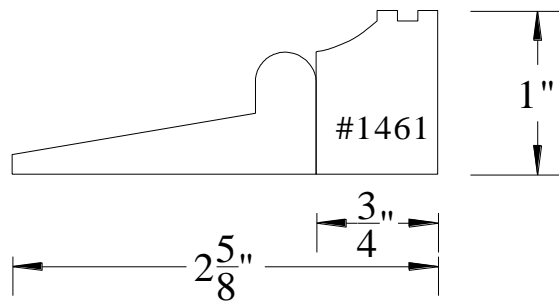
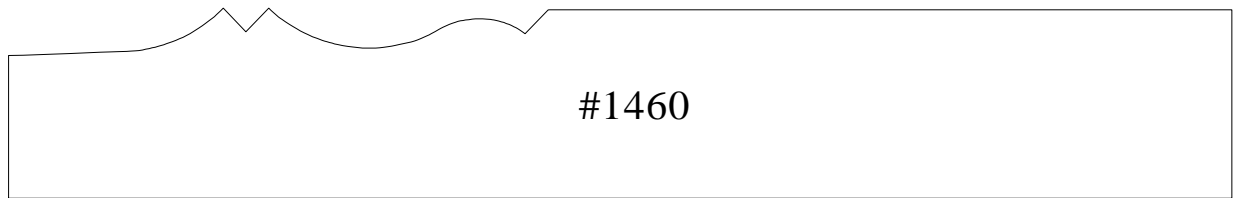
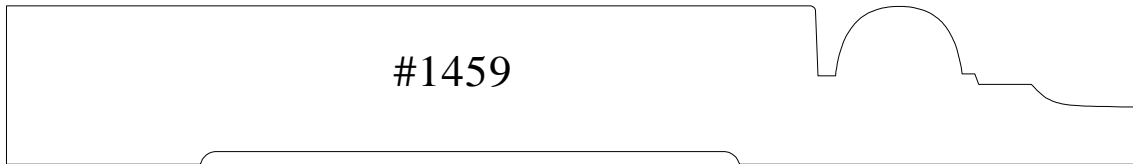
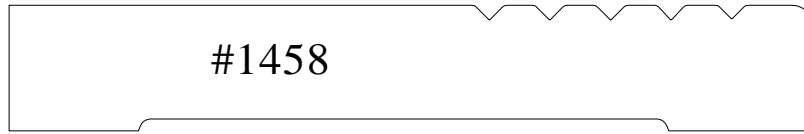

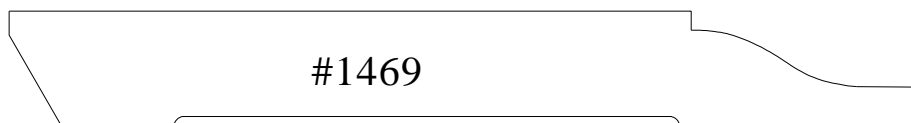
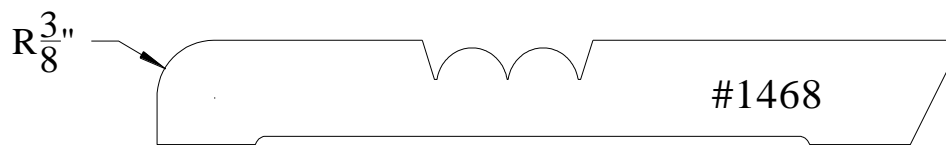
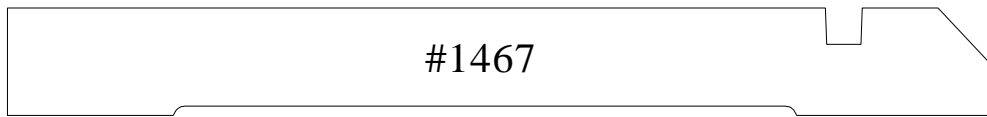
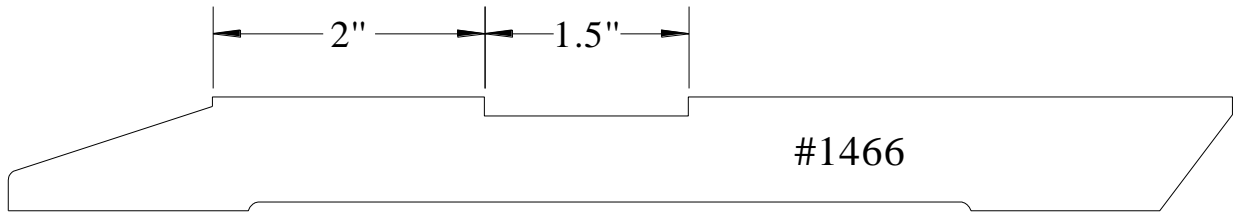
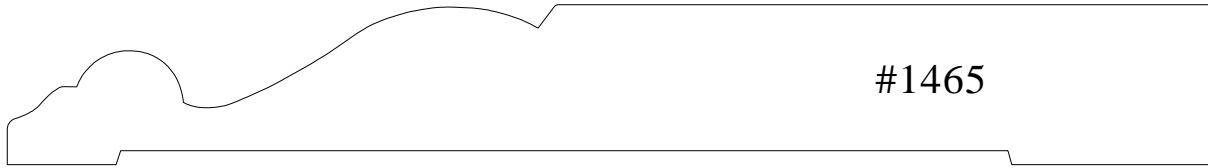
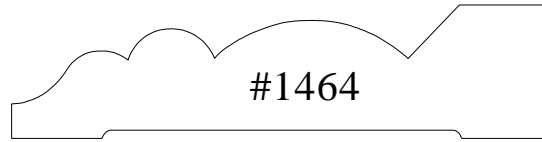

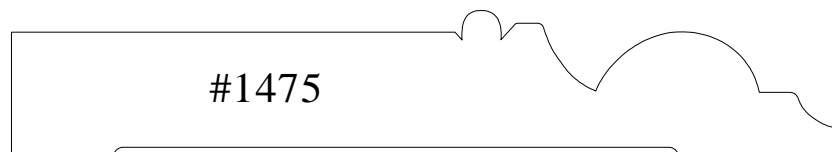
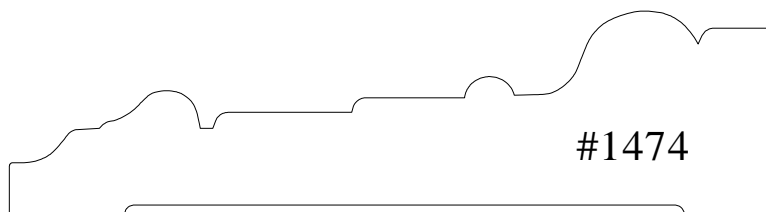
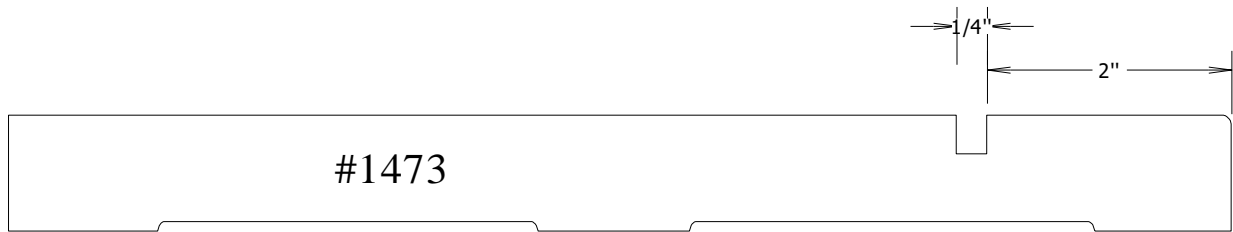
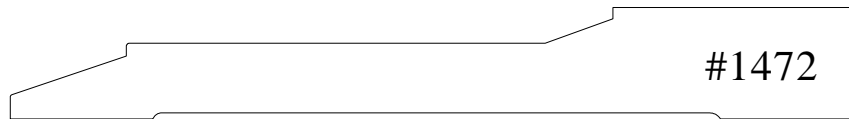
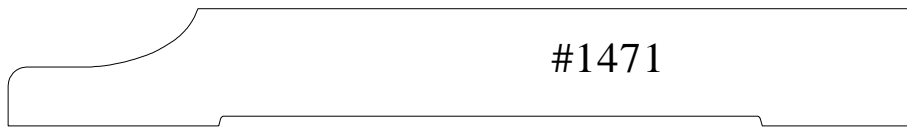
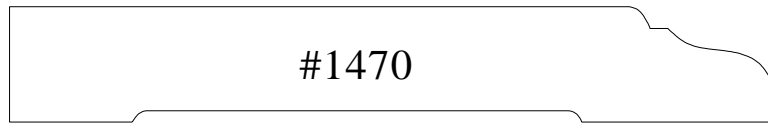

# Case Pages

These profiles generally can only be made into case.

Typically, casings stand proud of the base in thickness by  $1/8''$ .

We can make the case thicker or thinner than what is shown and in some instances narrower but not wider.

The thickest we can mill a case using  $4/4$  stock is  $13/16''$ , using  $5/4$  stock is  $1''$ , using  $6/4$  stock is  $1/25''$  and using  $8/4$  stock is  $1.625''$ .



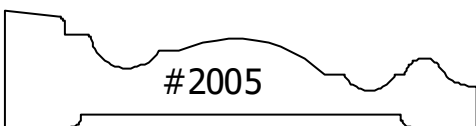
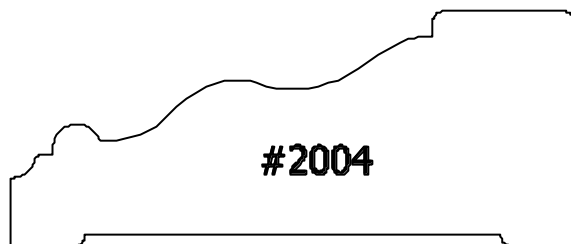
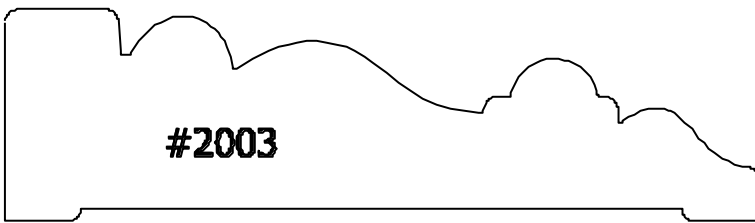
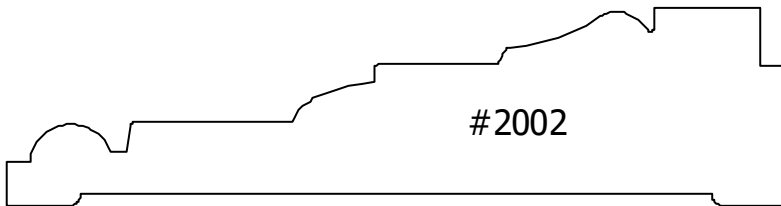
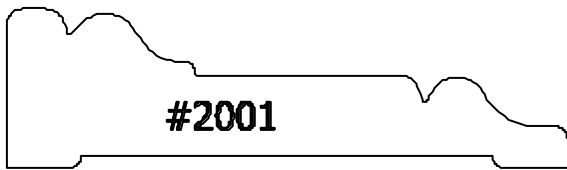
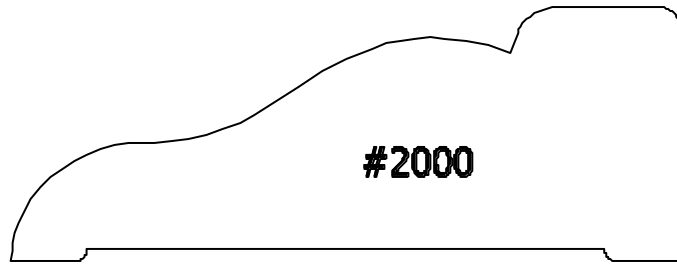

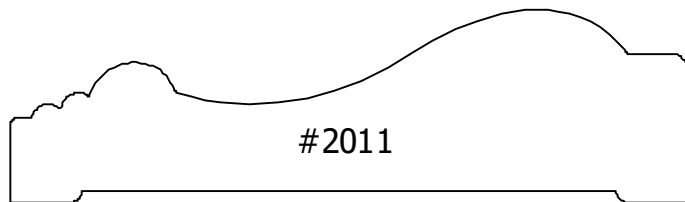
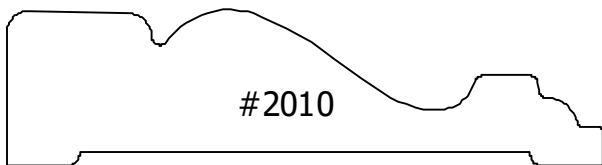
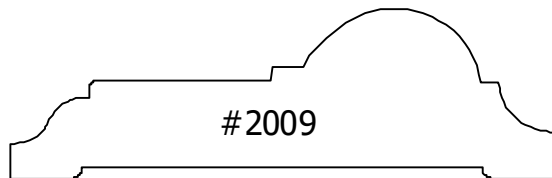
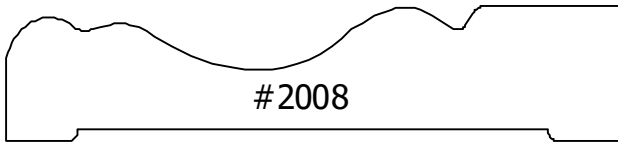
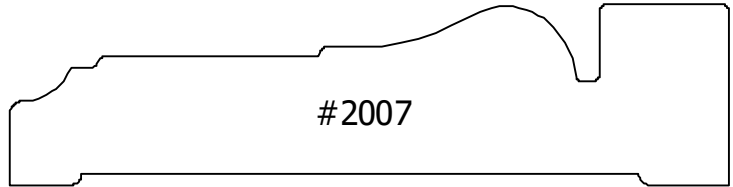

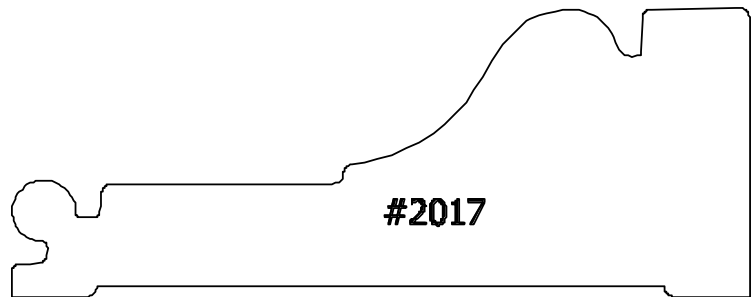
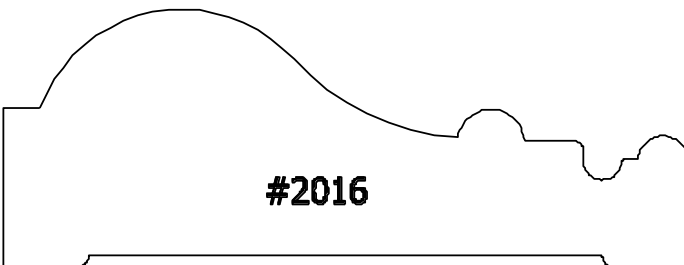
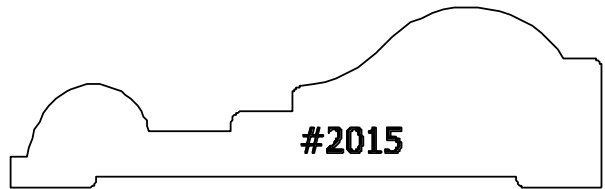
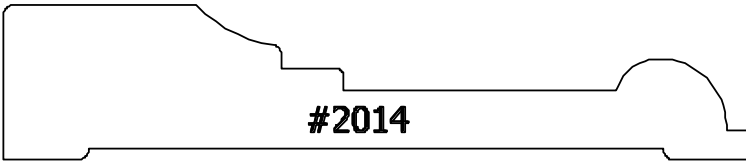
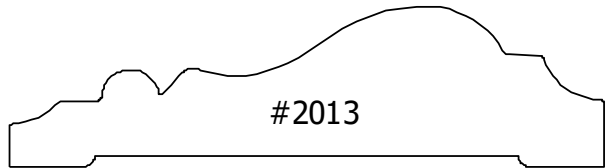
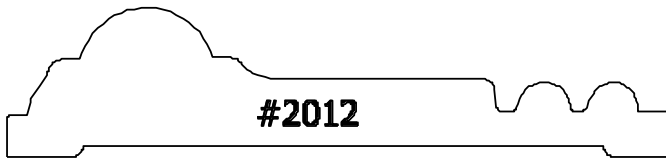

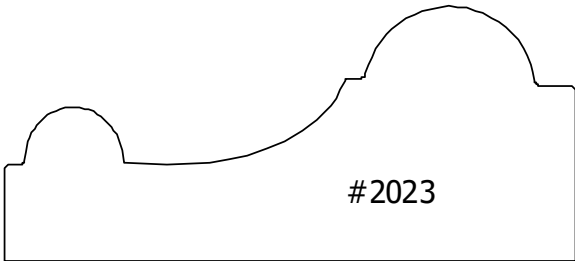
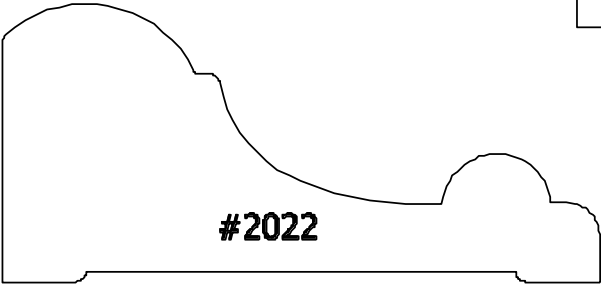
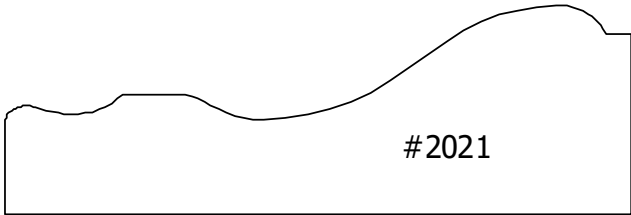
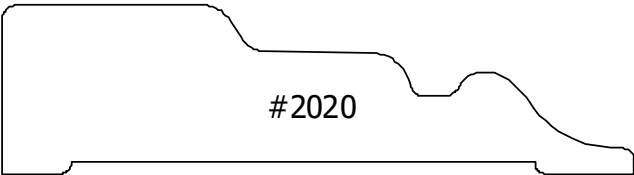
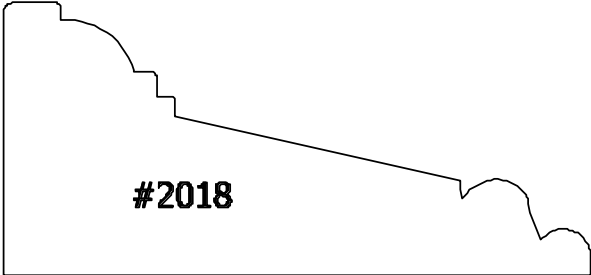

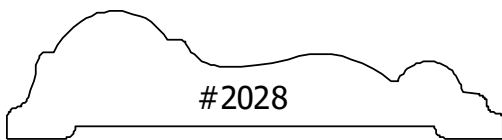
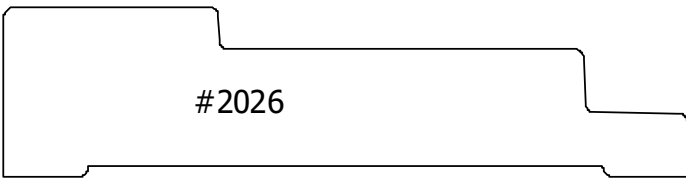
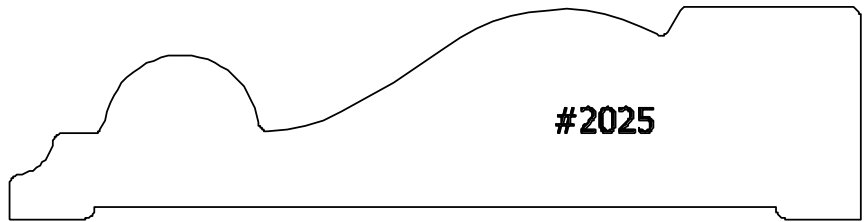
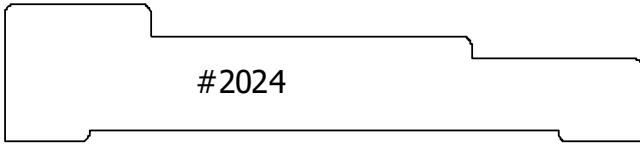

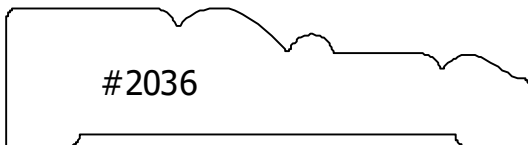
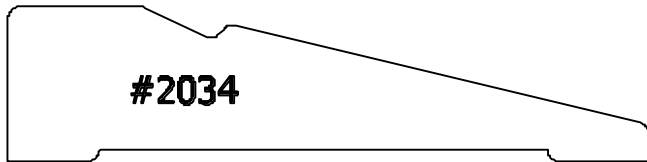
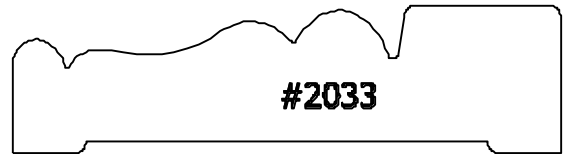
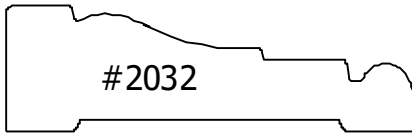
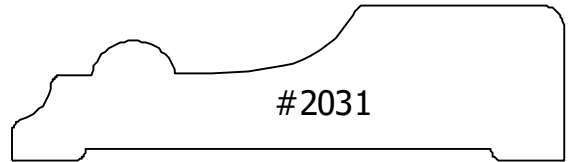
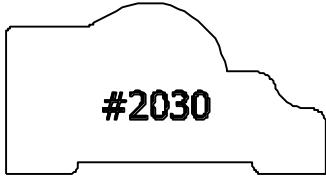

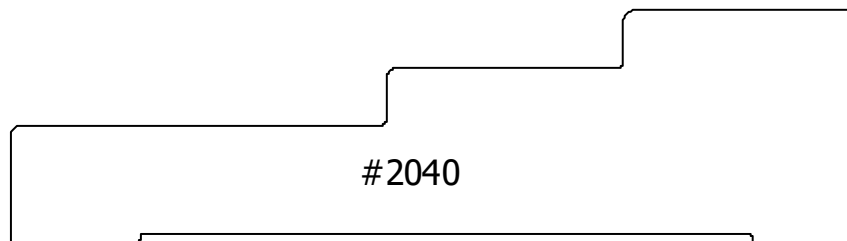
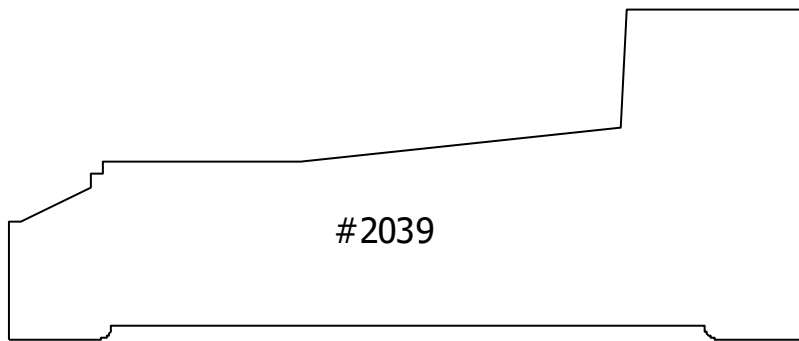
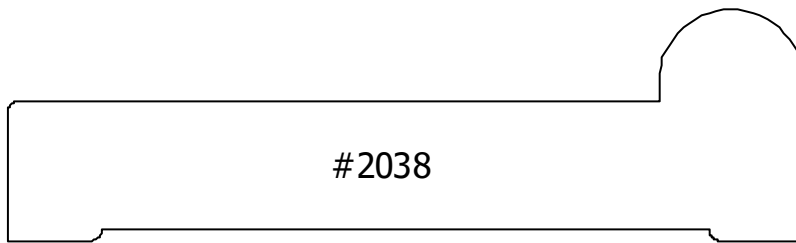
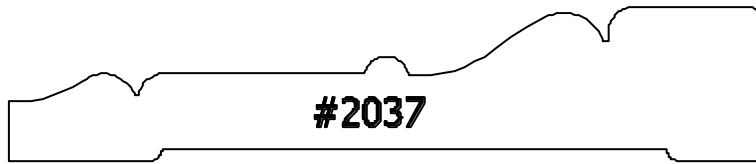

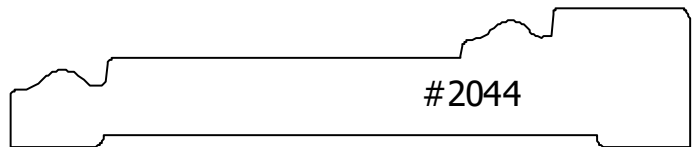
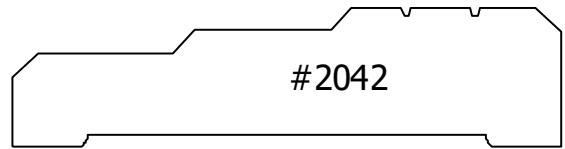



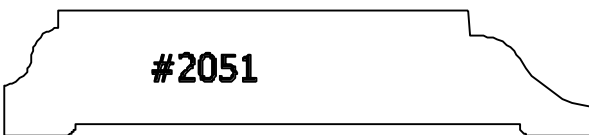
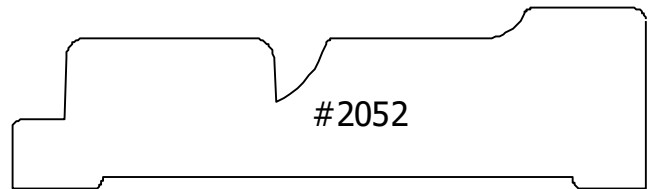
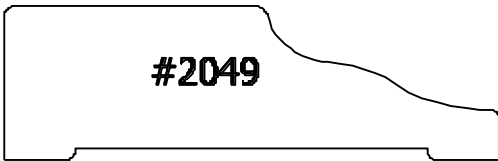
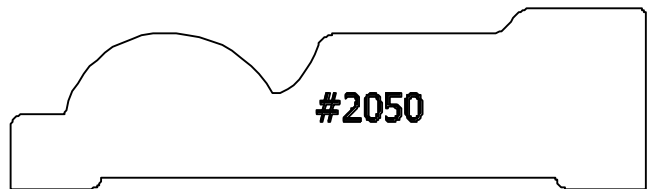
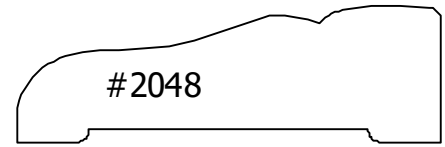

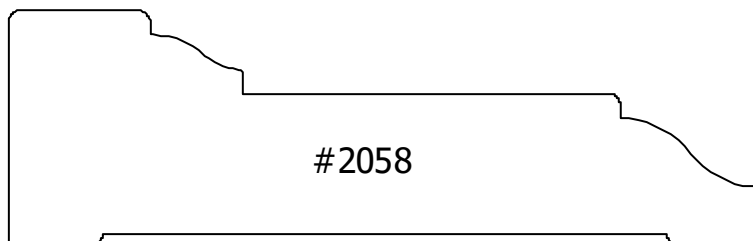
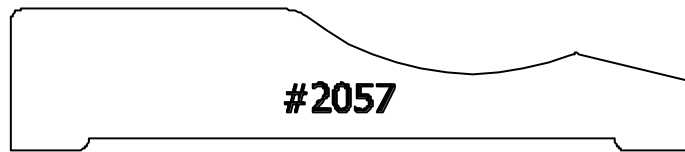
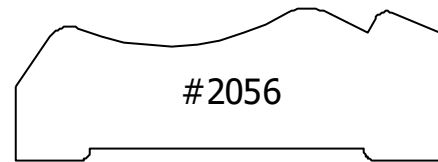
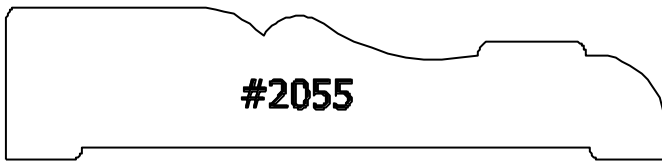
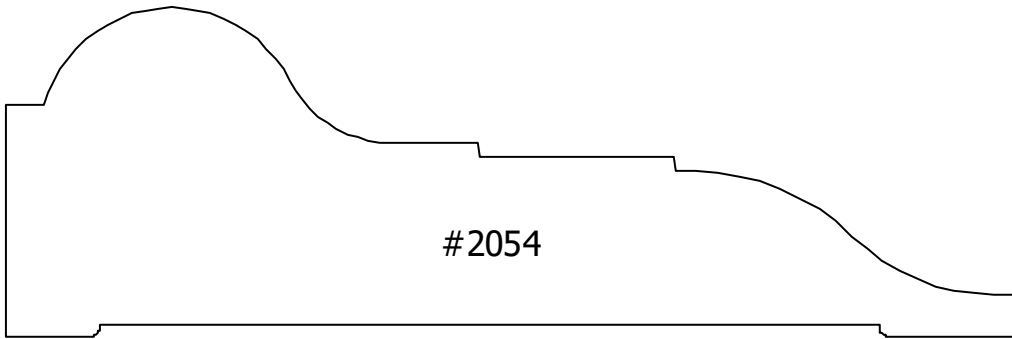

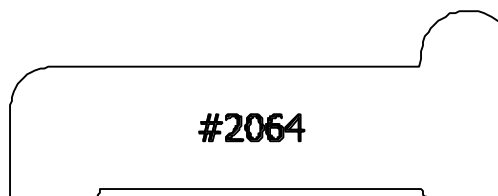
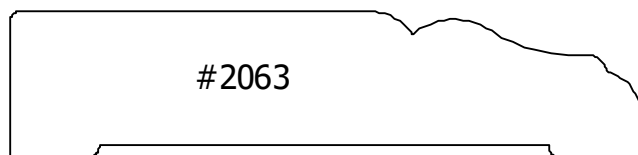
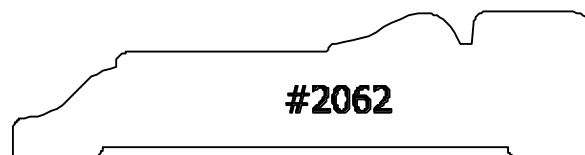
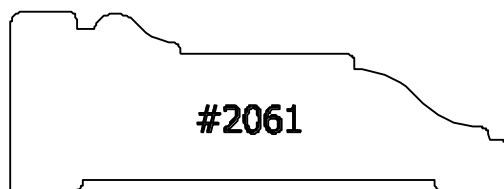
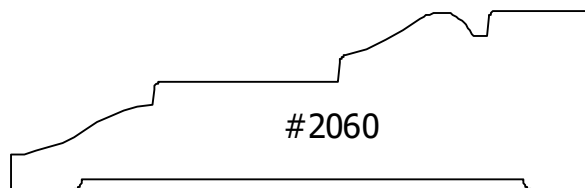
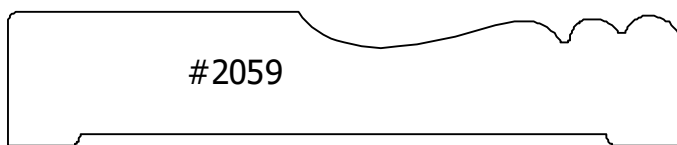

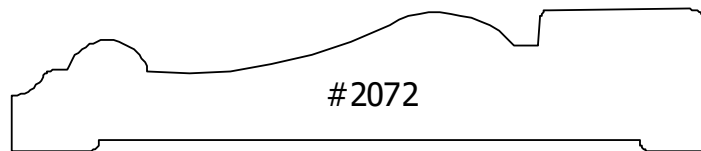
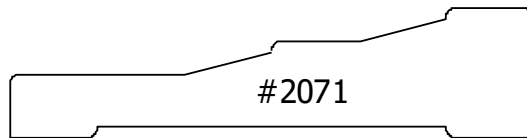
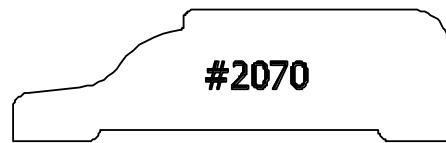
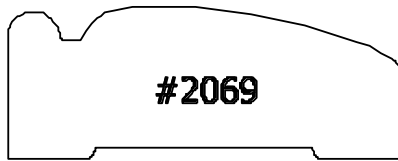
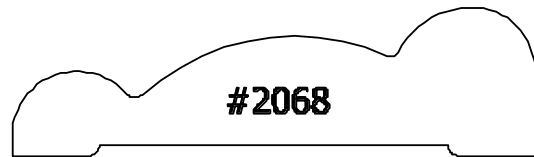
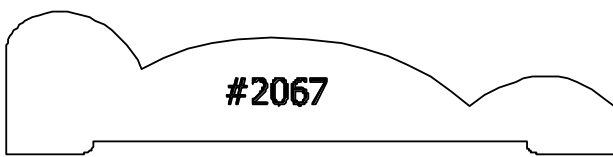
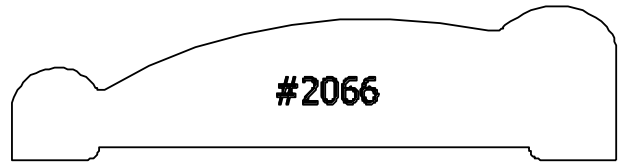
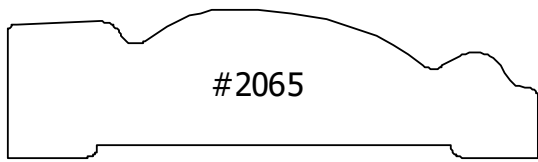

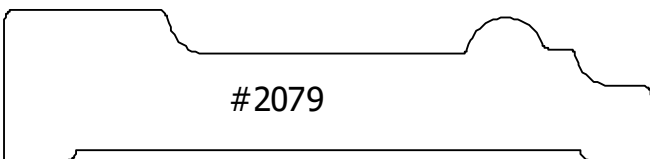
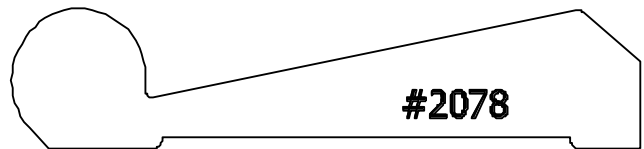
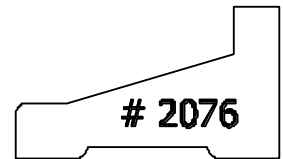
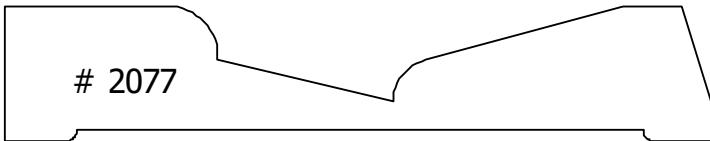
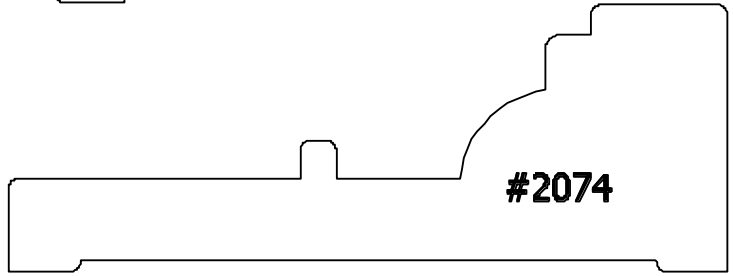
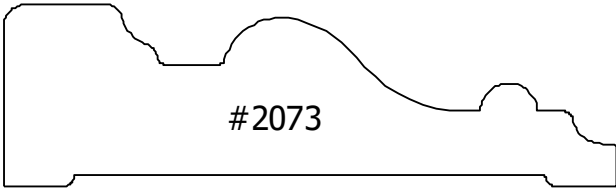

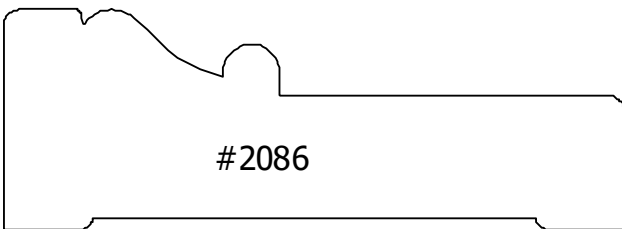
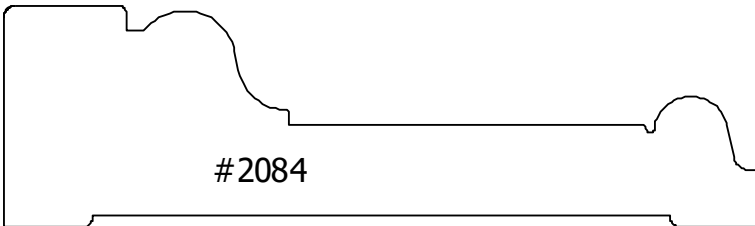
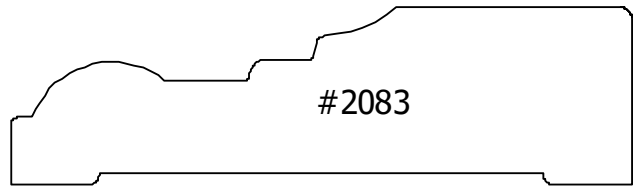
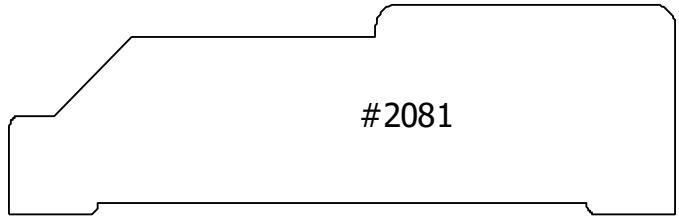
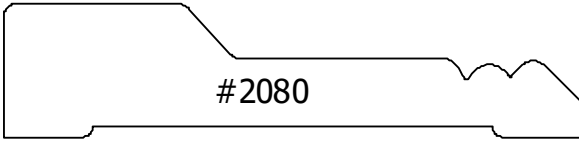

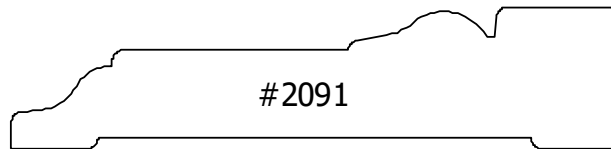
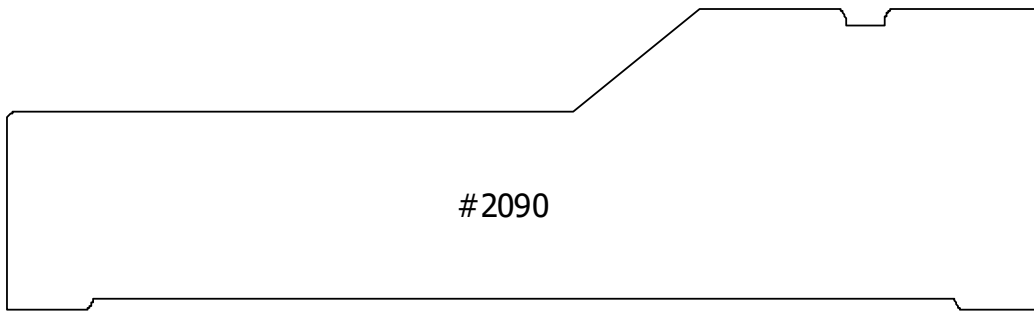
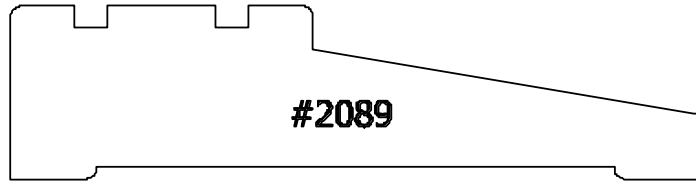
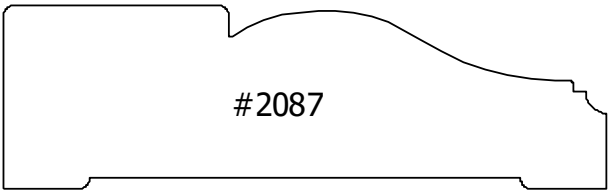

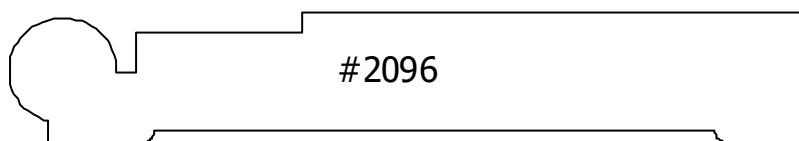
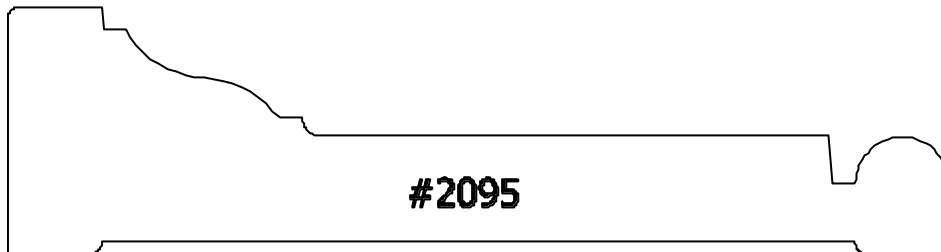
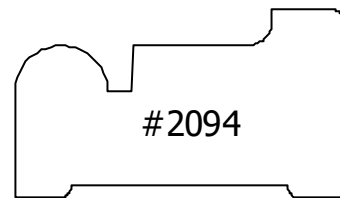
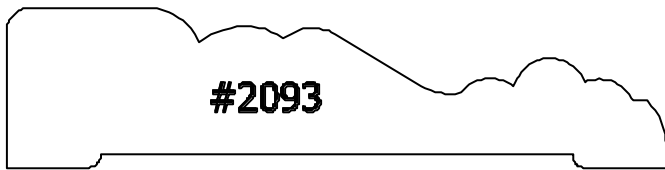
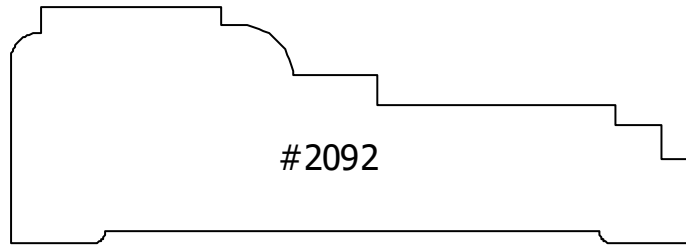



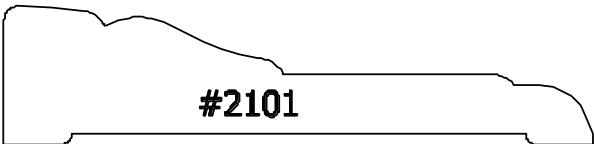
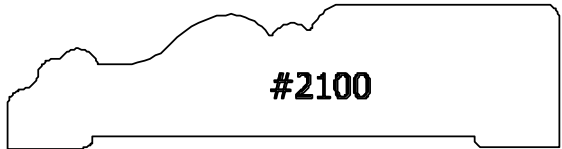
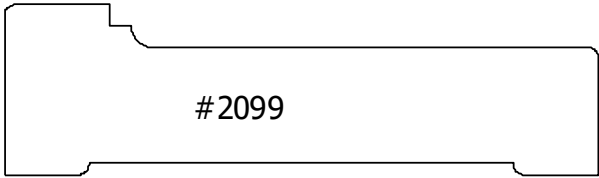
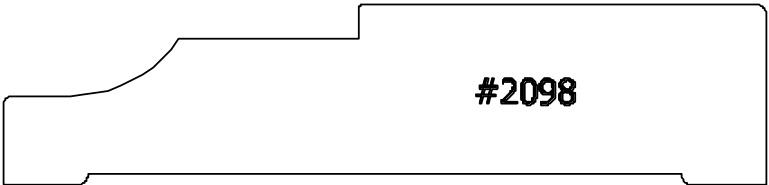
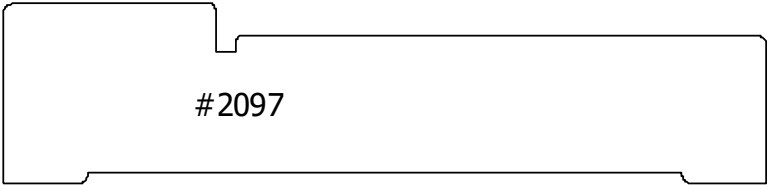

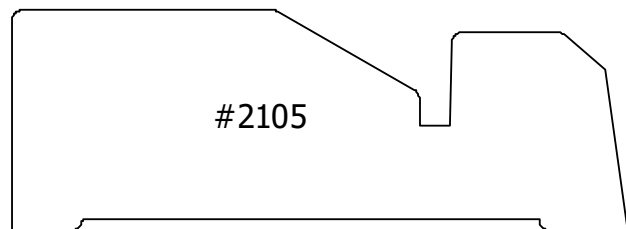
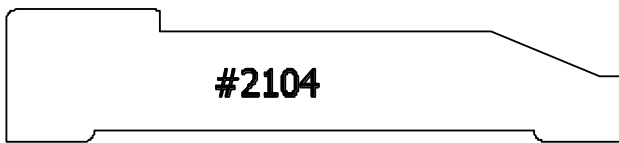

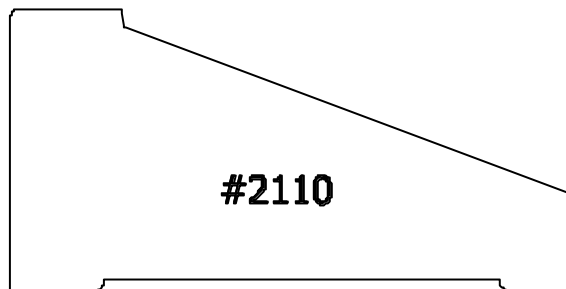
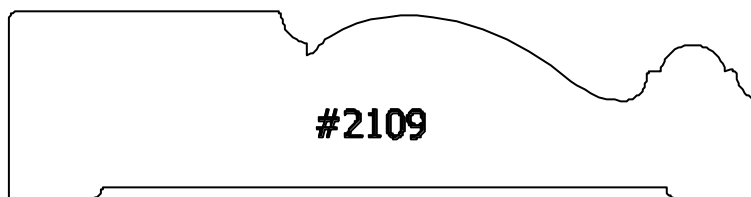
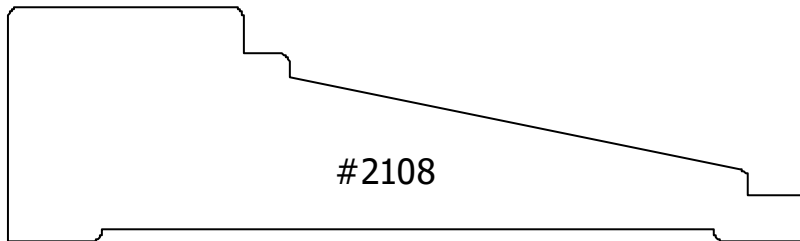
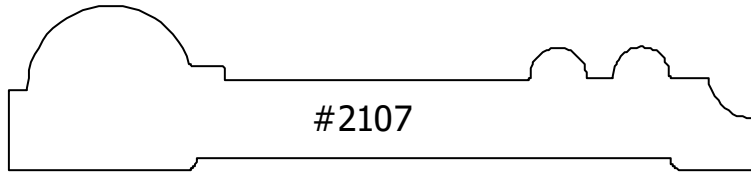

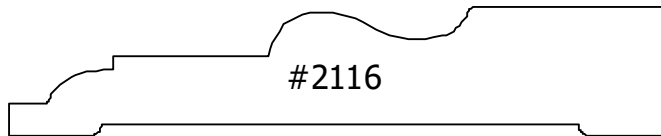
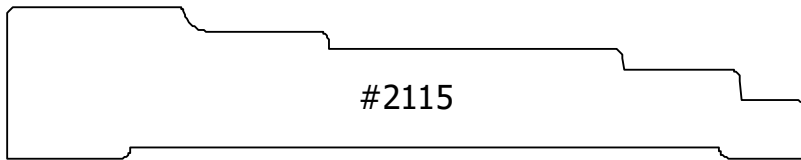
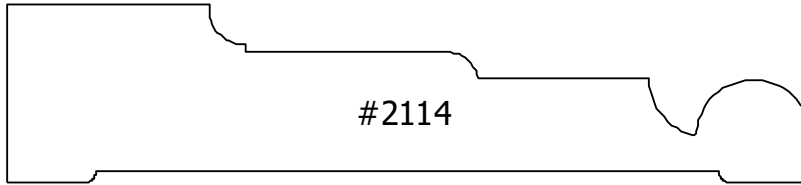
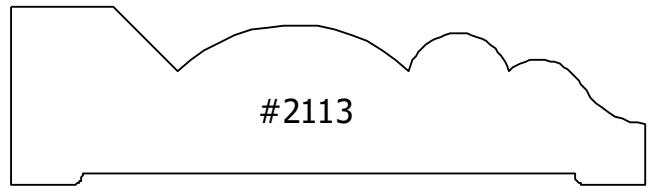
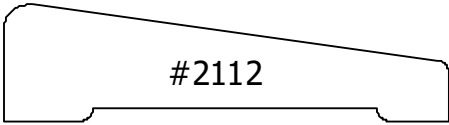
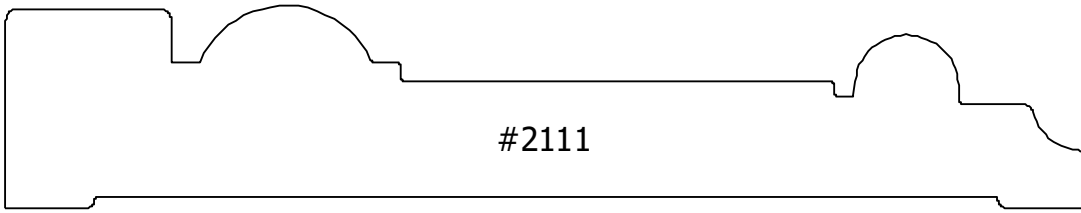

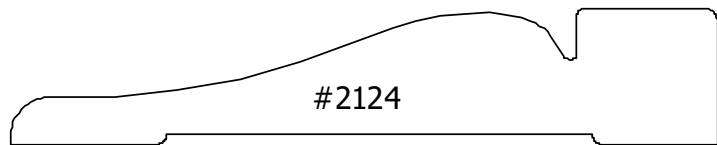
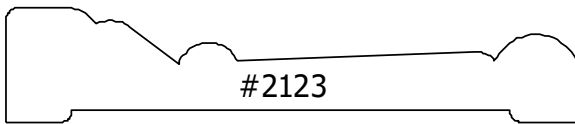
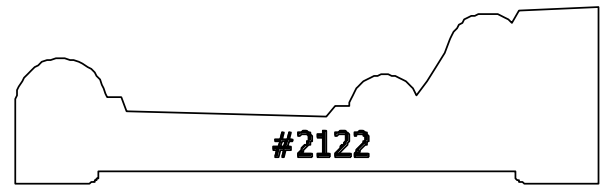
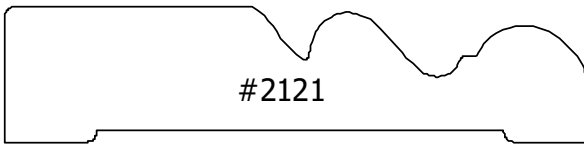
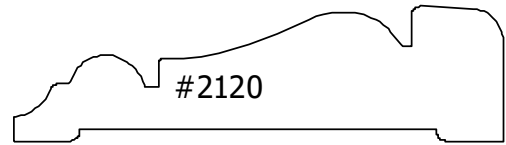
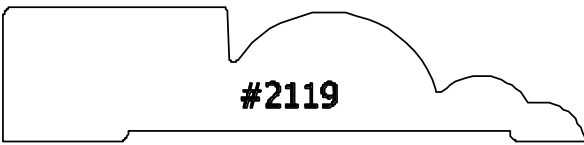
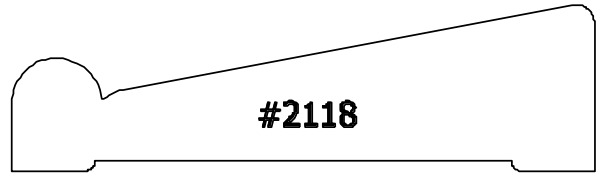
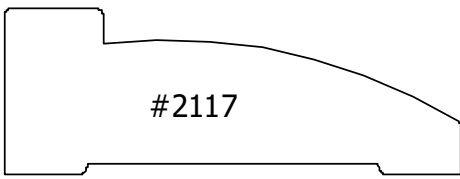

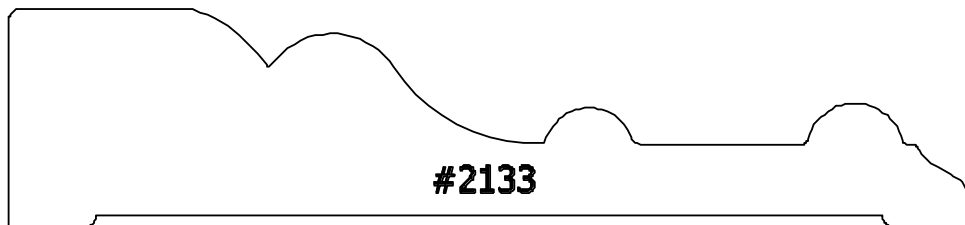
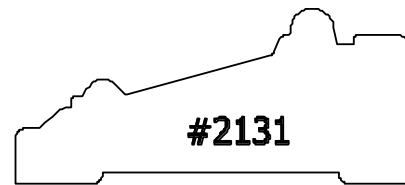
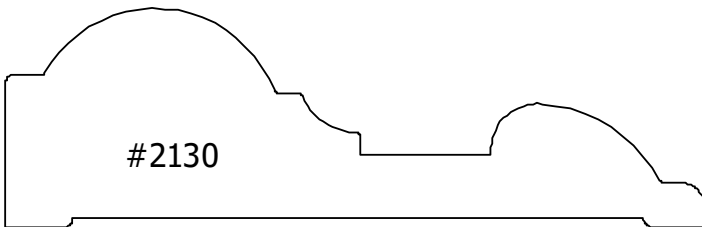
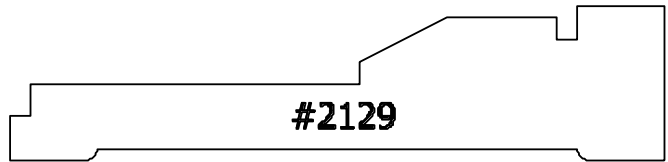
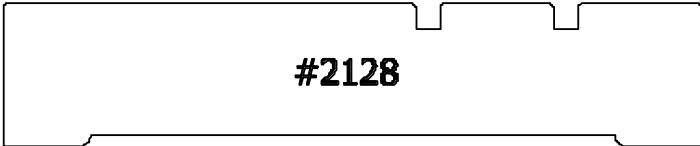
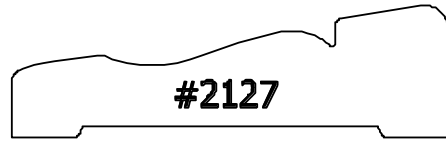
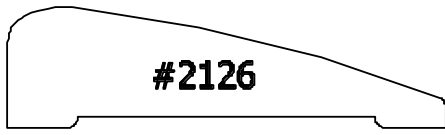

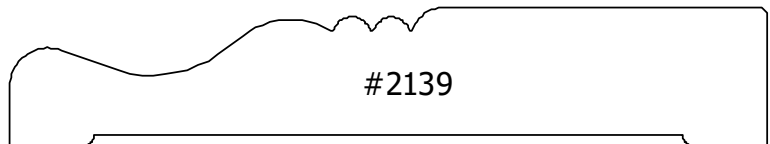
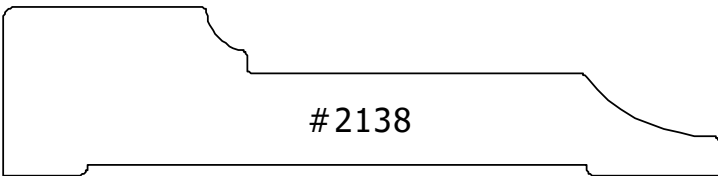
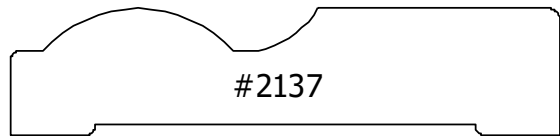
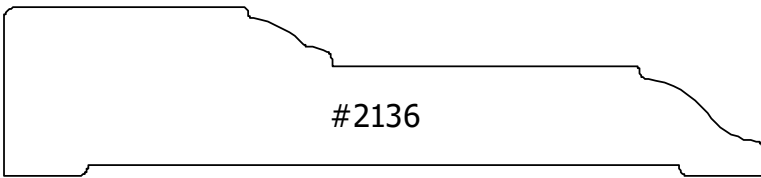
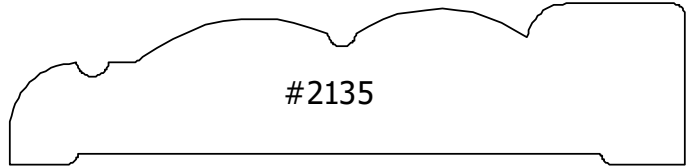
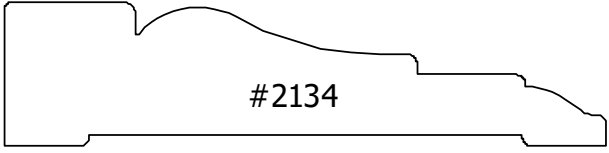

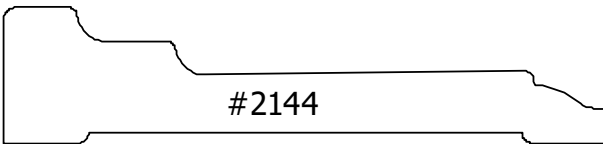
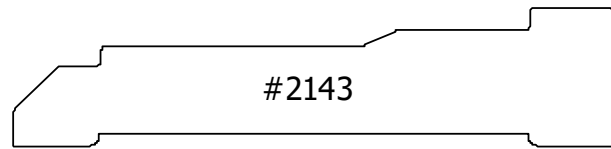
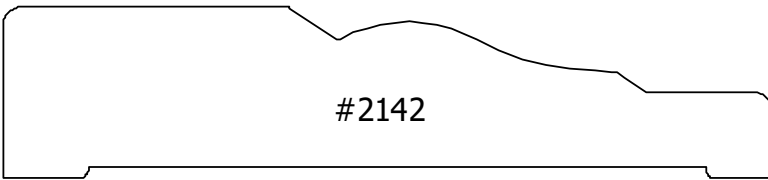
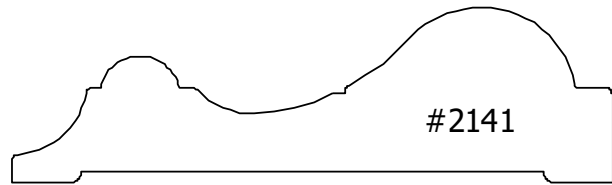
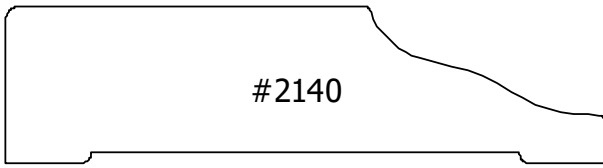



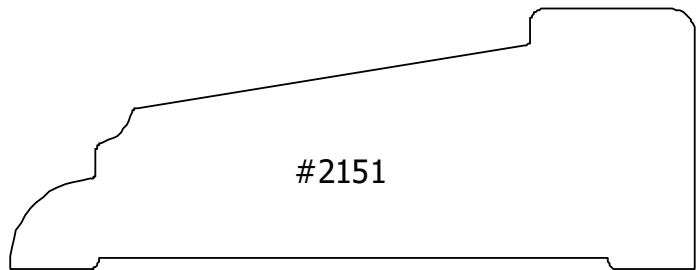
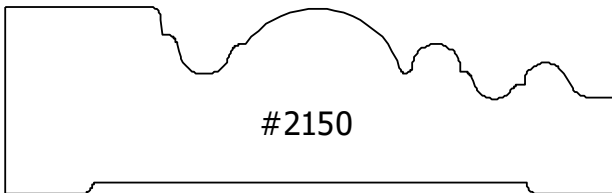
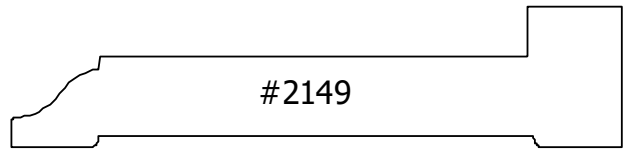
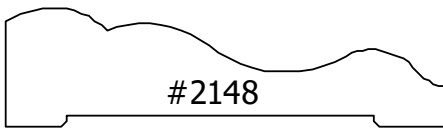
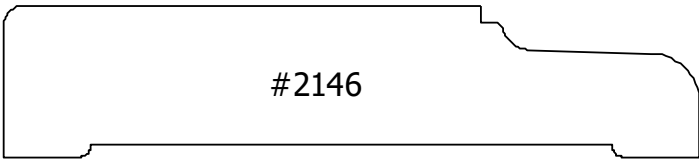

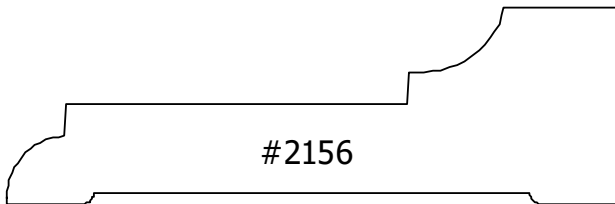
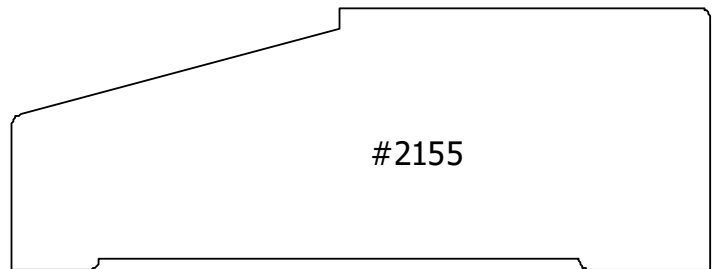
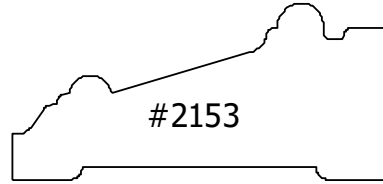

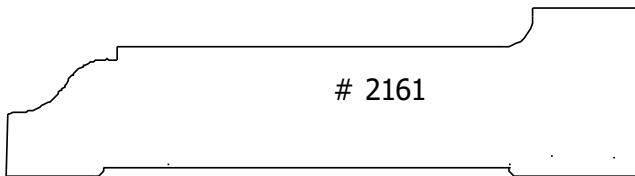
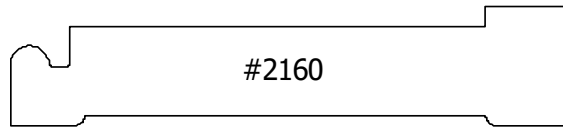
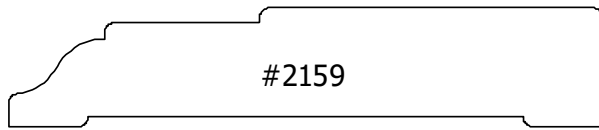
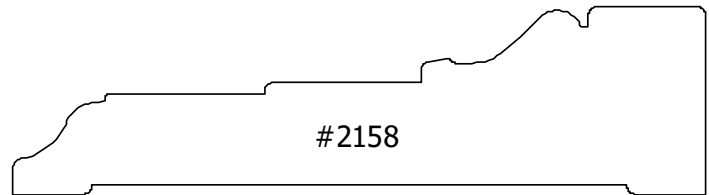
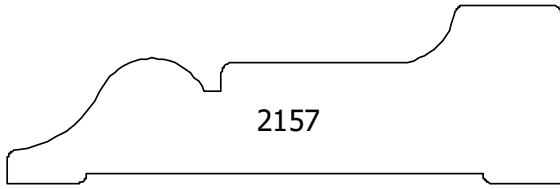

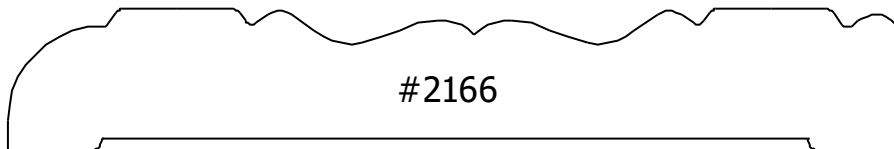
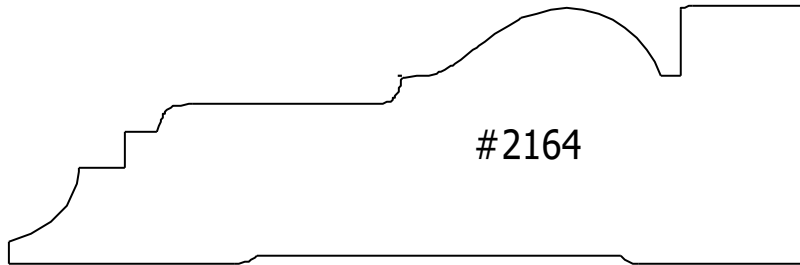
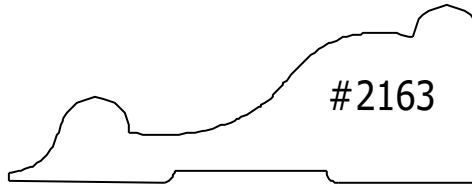

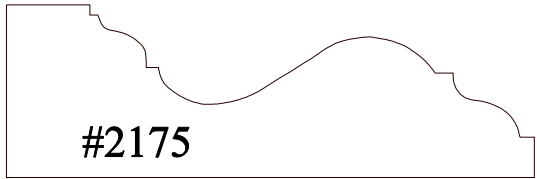
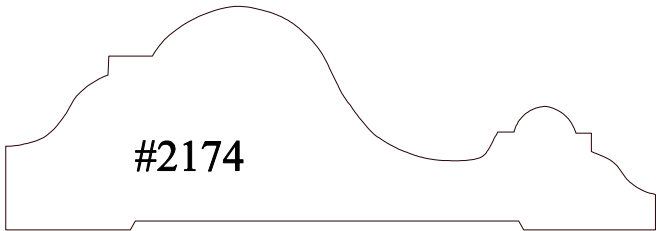
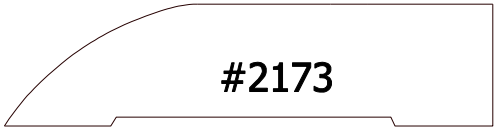
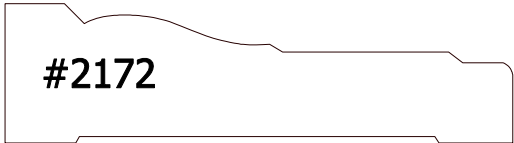
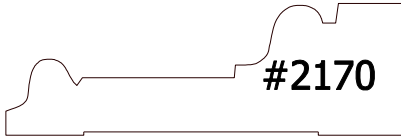
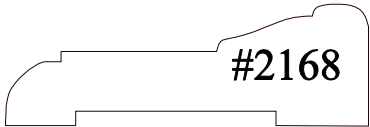

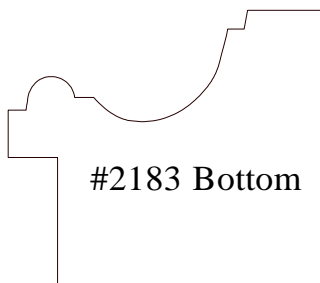
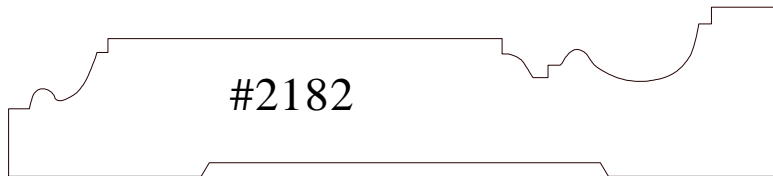
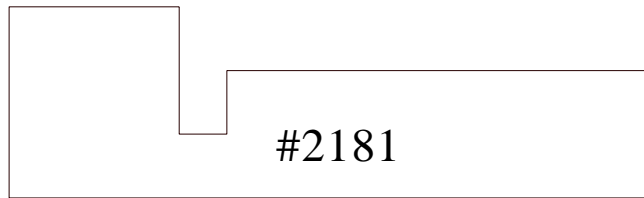
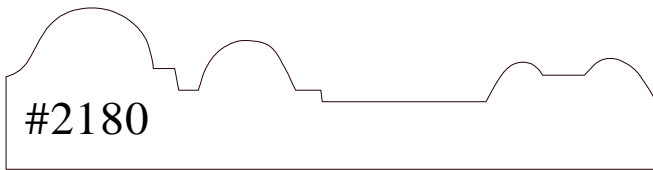
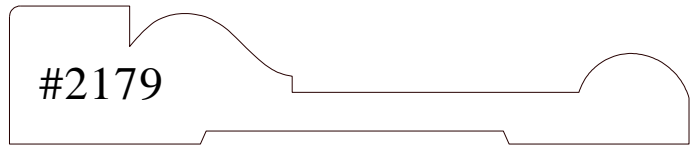

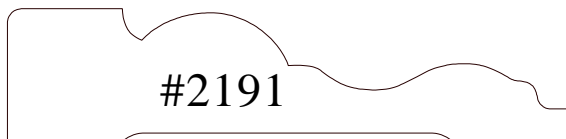
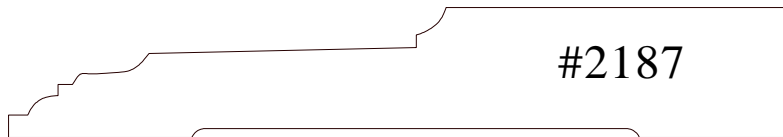
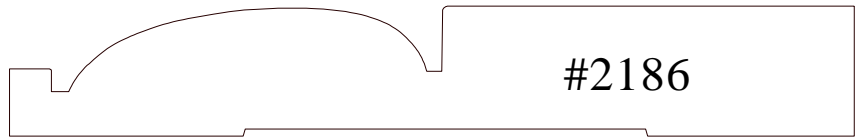
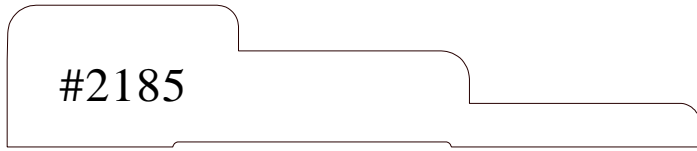

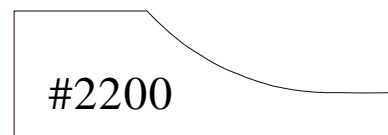
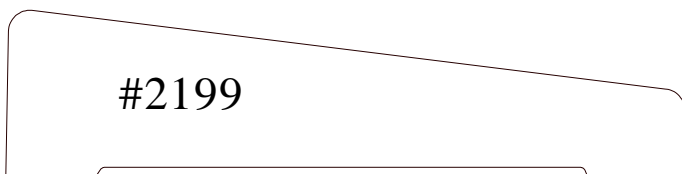
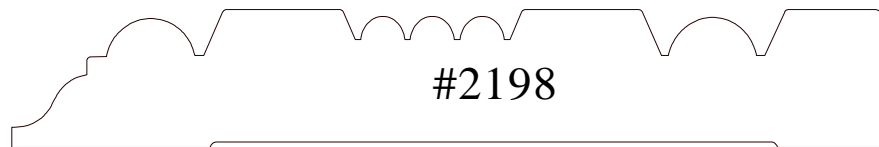
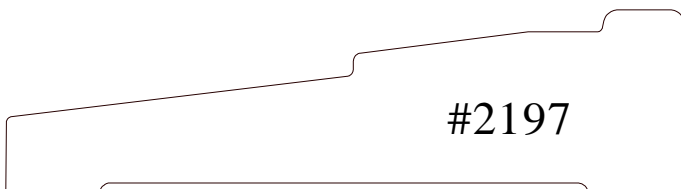
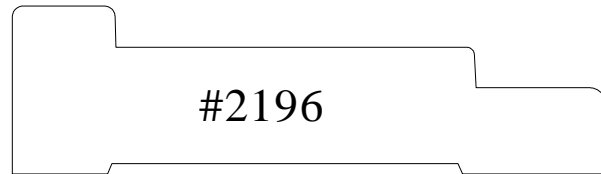
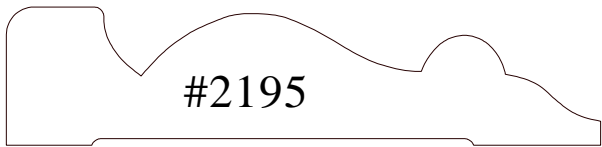
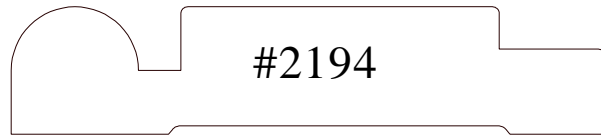
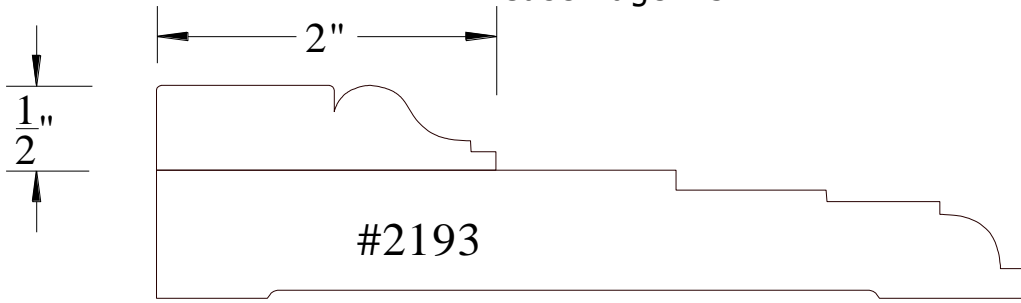



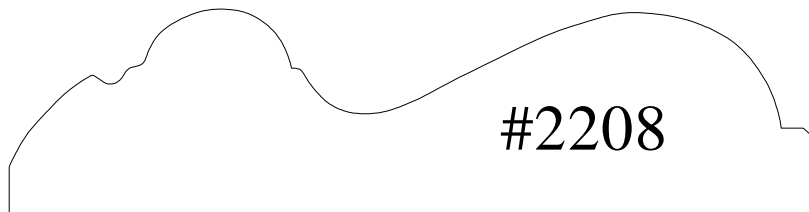
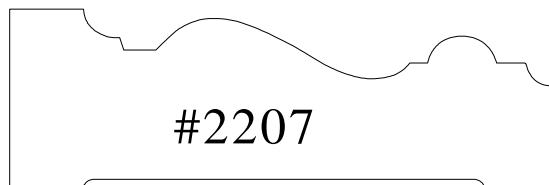
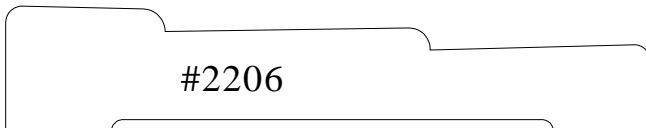
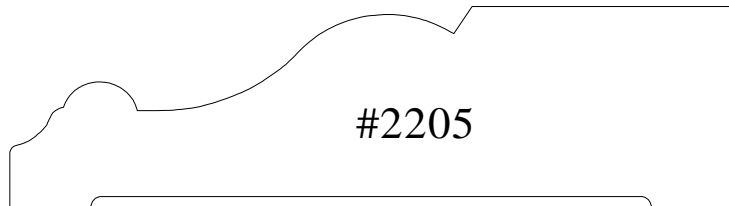
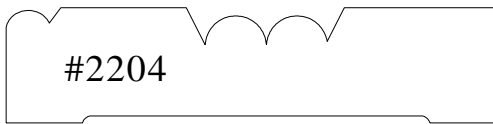
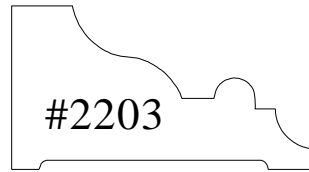
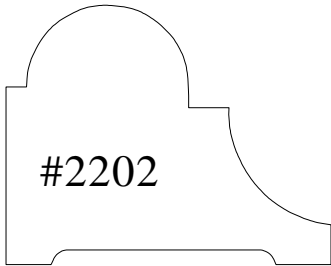
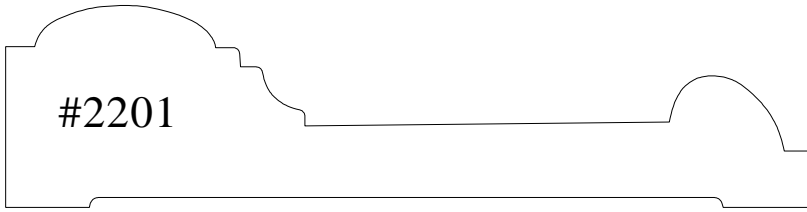

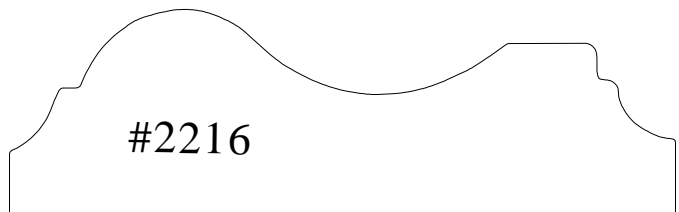
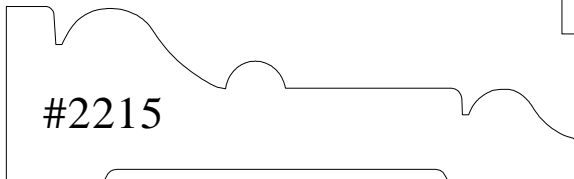
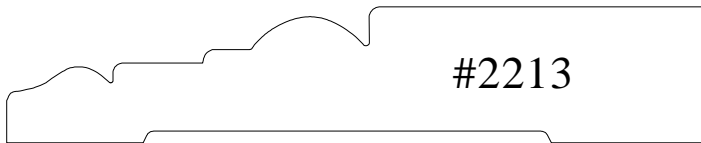
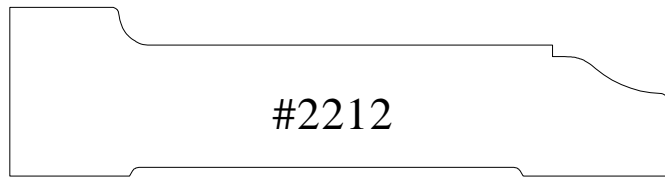
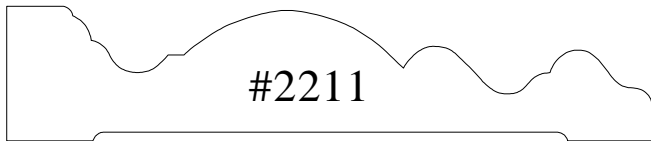
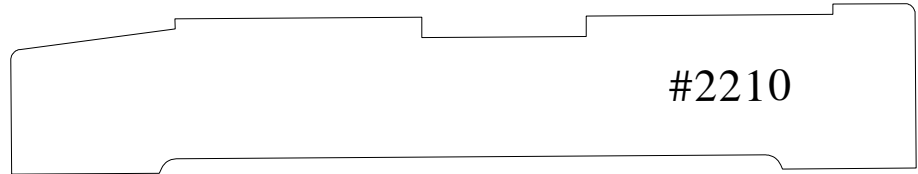
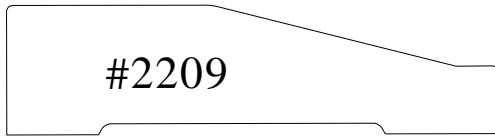

# Symmetrical Case Pages

These profiles are what we term “symmetrical” profiles.

Typically, these types of cases are used with plinths and/or rosettes.

Sometimes these profiles are used as chair rails.

These profiles can be modified in thickness and made narrower.

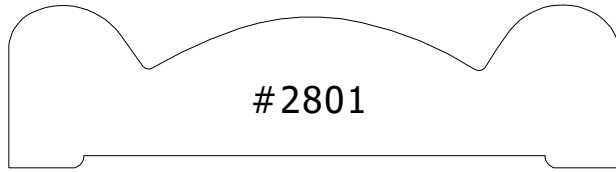
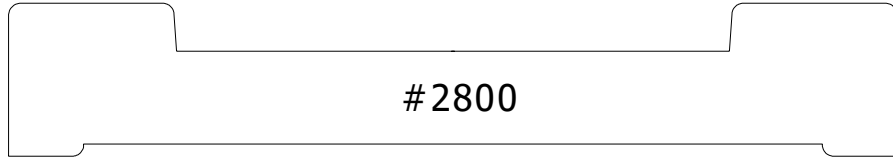

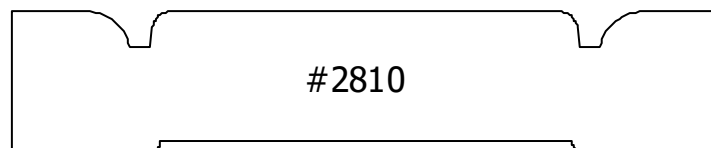
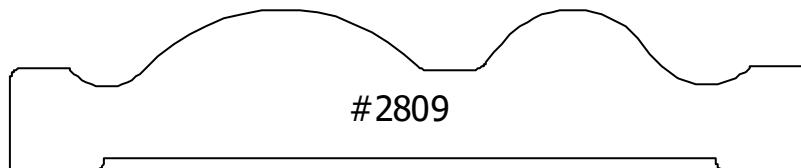
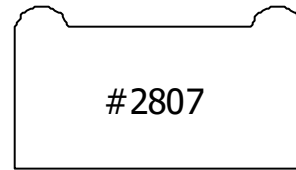
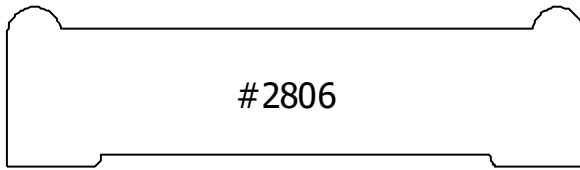

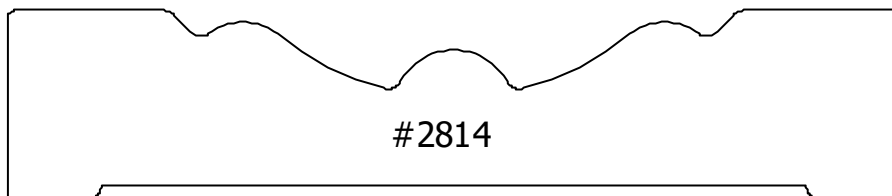
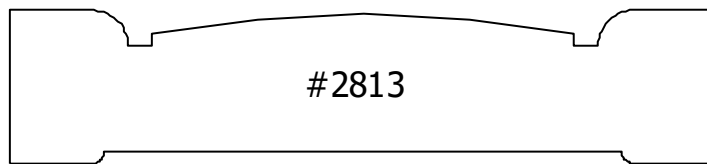
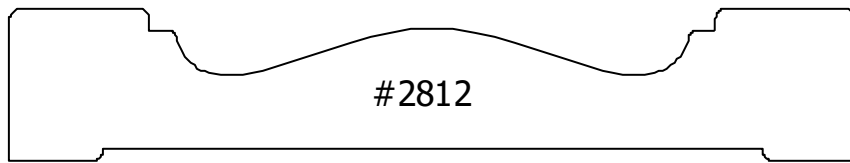
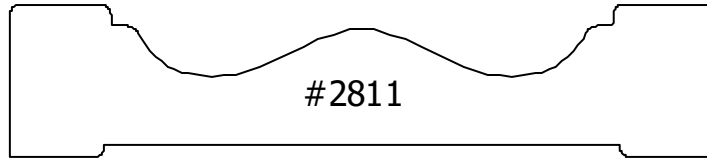

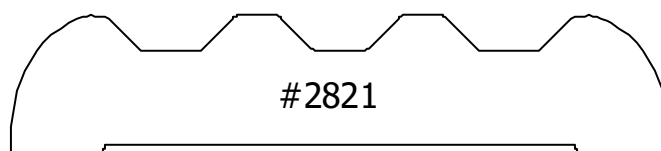
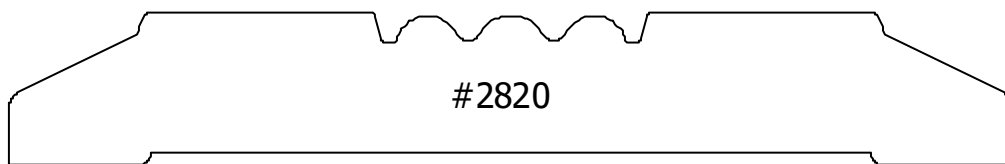





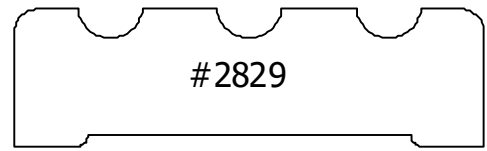
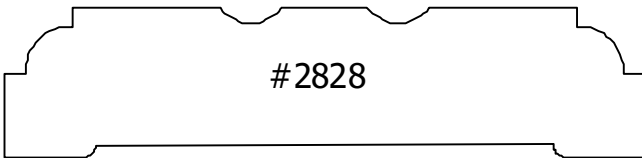
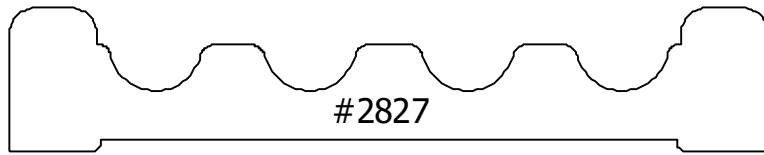

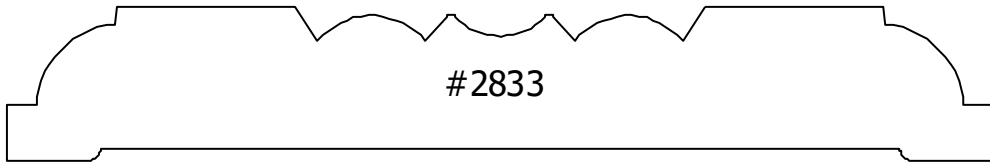

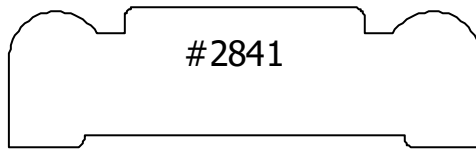
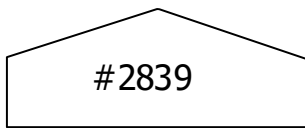

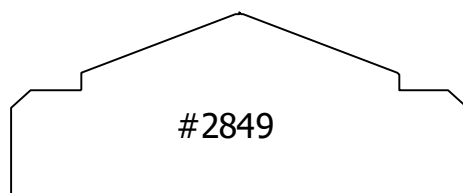
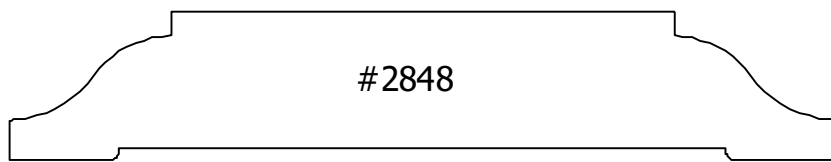
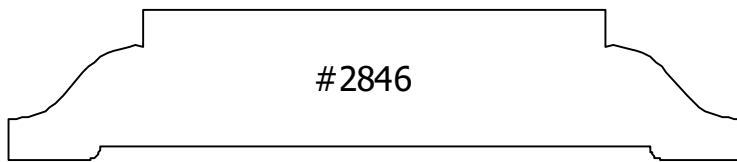
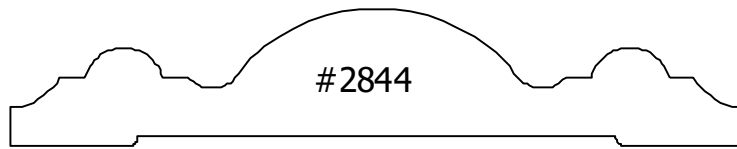

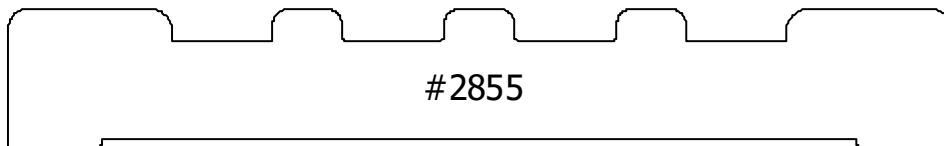
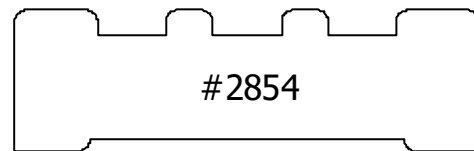
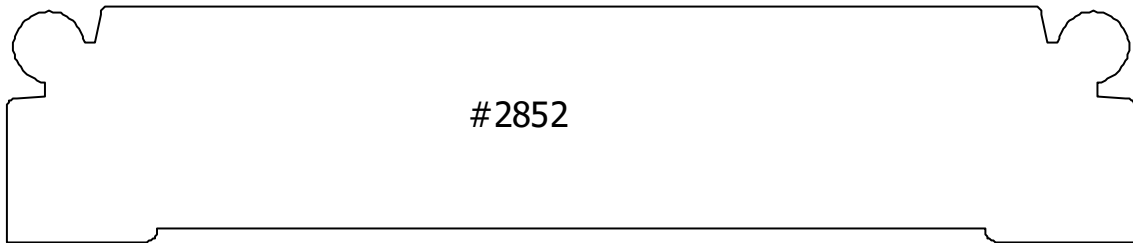
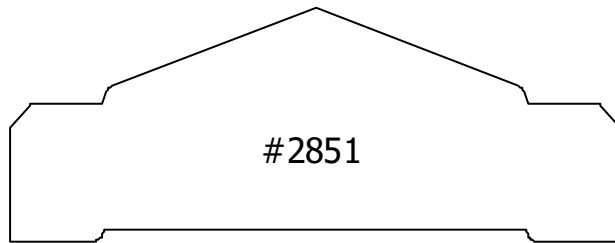
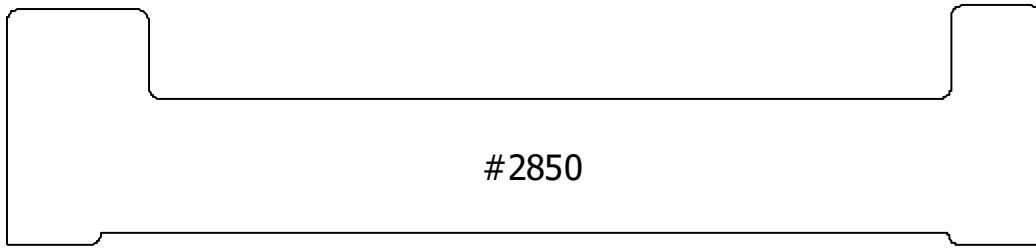

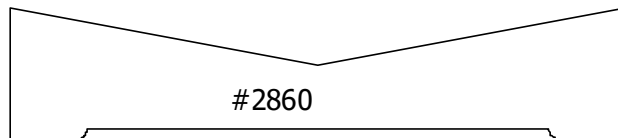
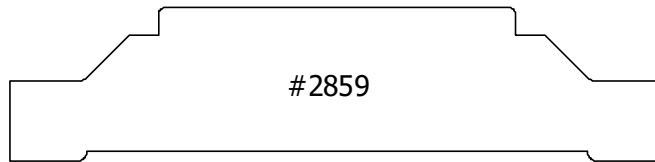
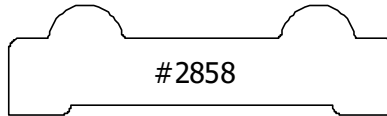
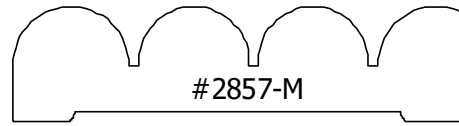

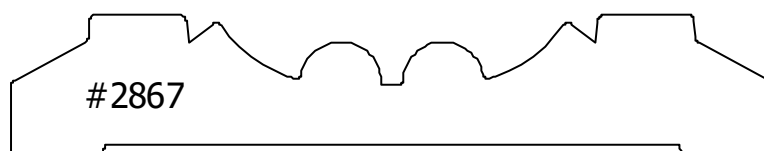
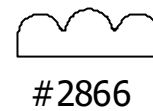
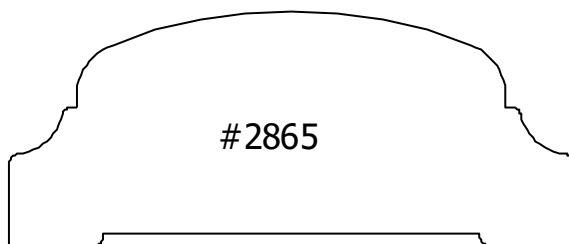
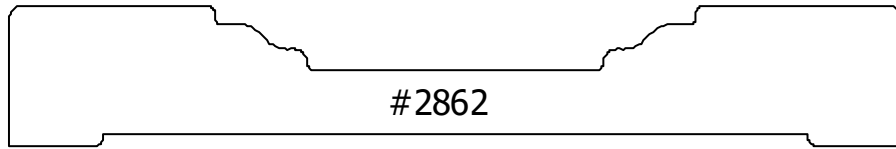

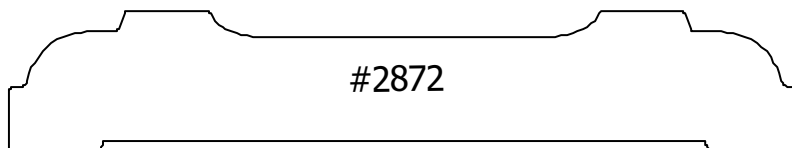
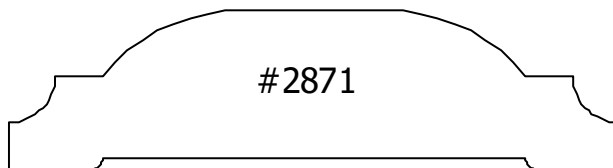
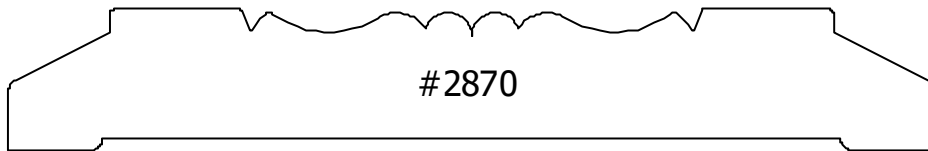
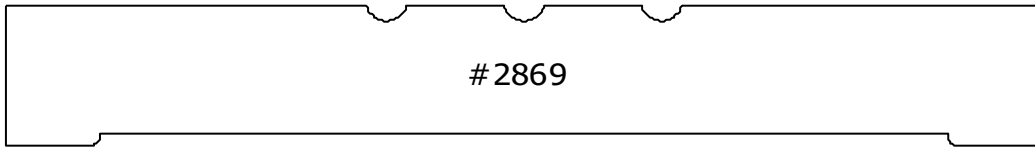



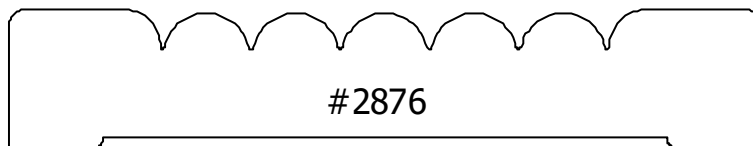
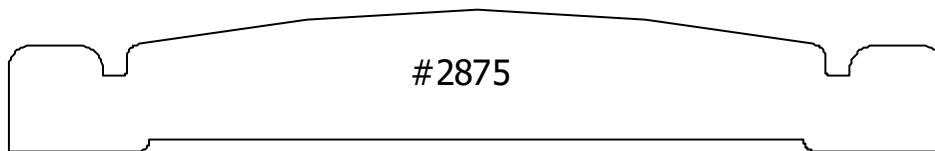
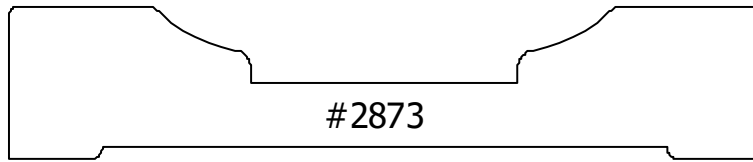

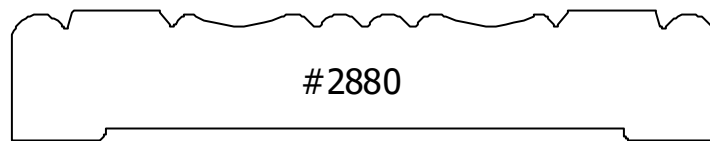
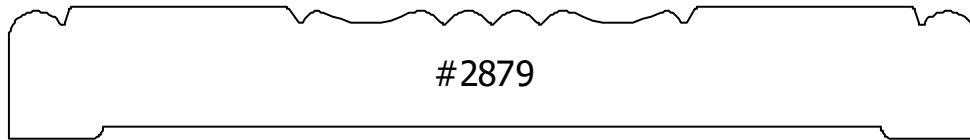
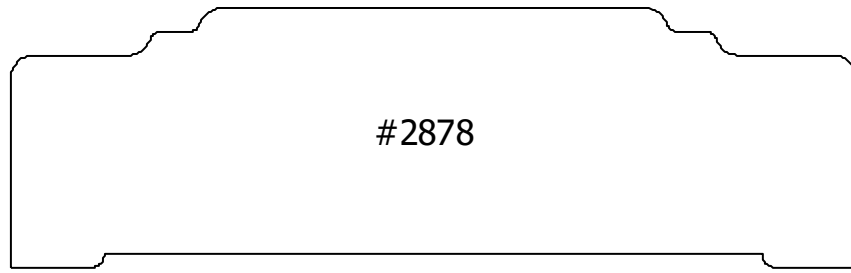

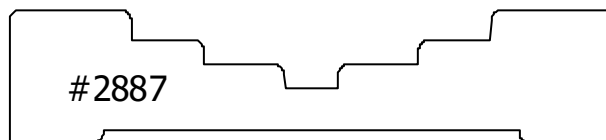
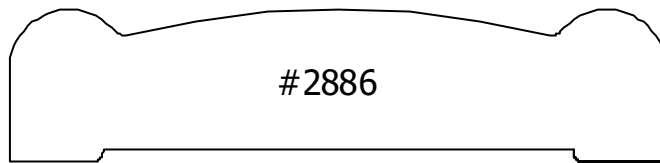

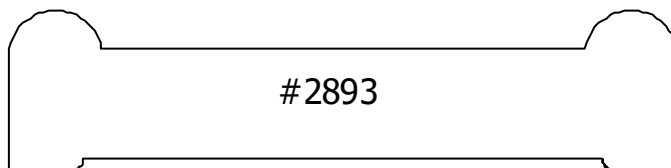
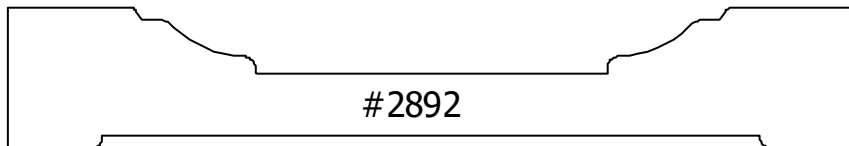
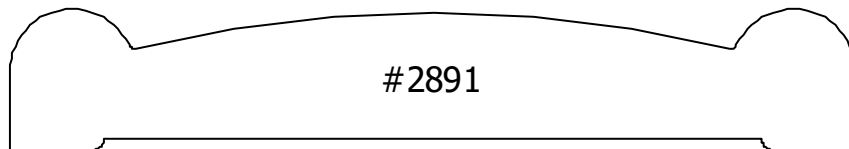

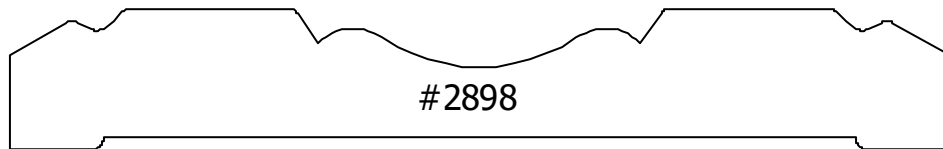
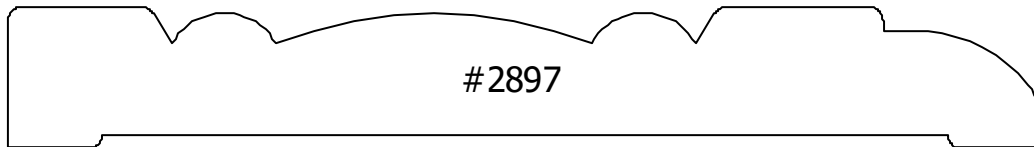
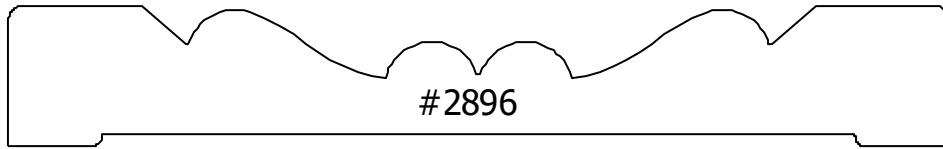
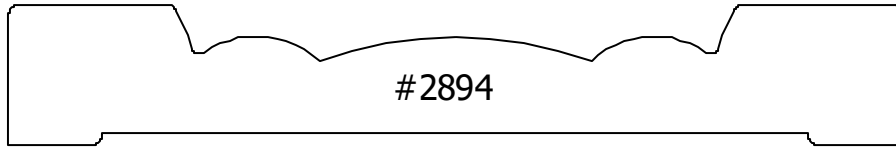



#2899



#2900

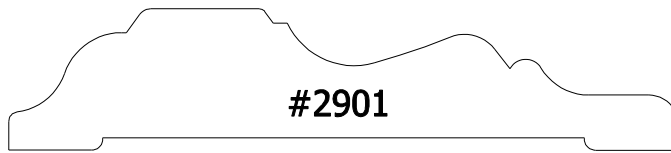

#2901

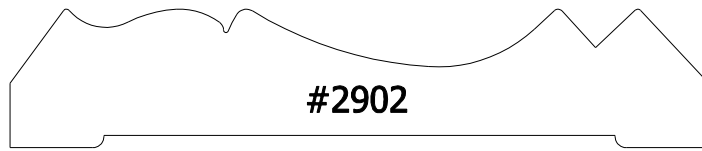

#2902



#2903



#2904

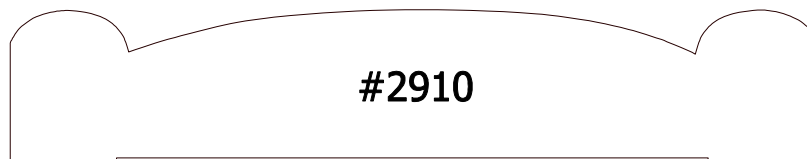
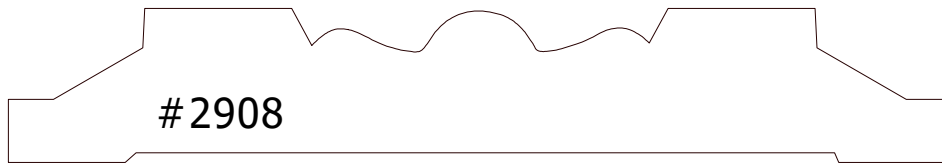
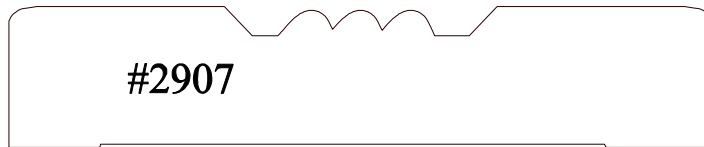
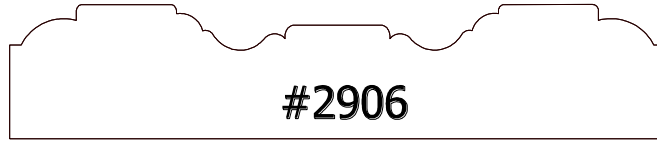

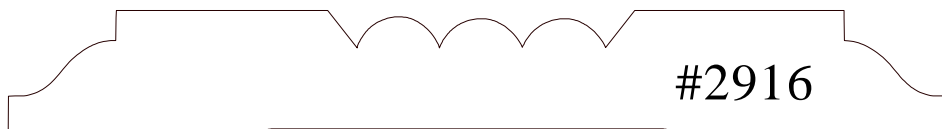
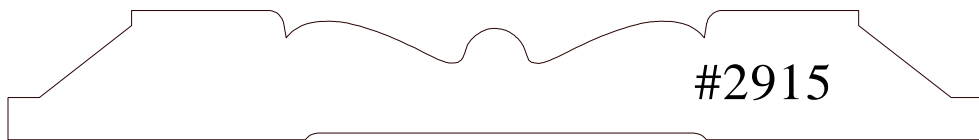
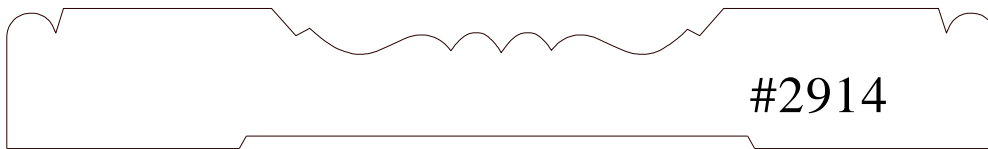
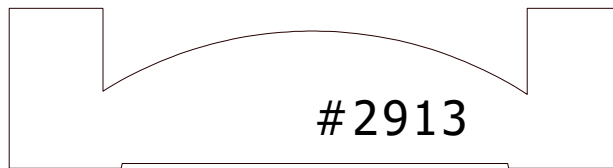
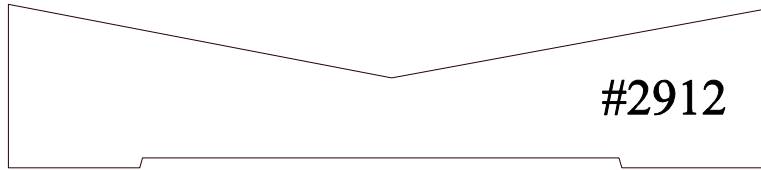
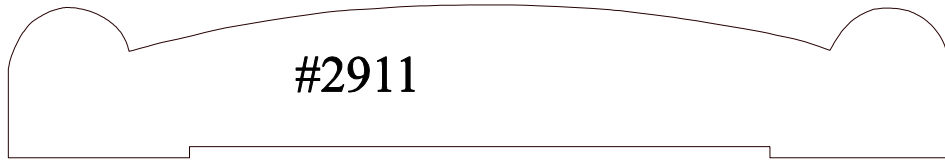



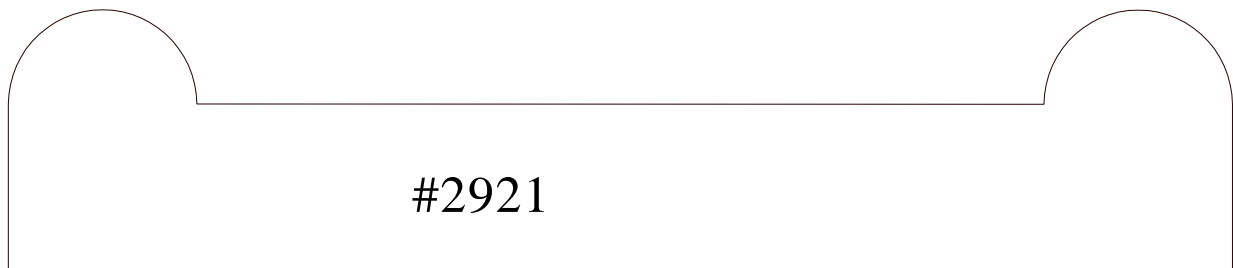
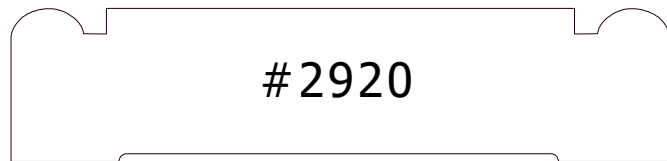
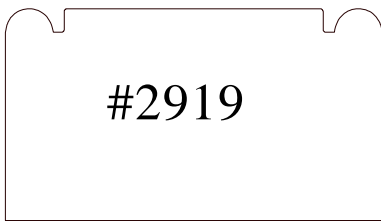
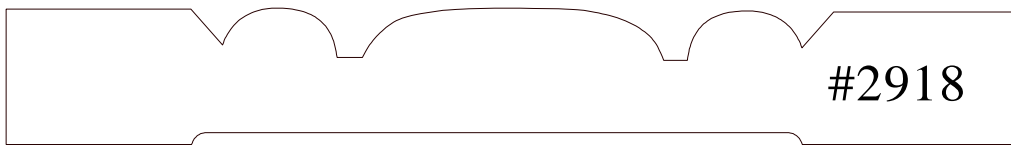

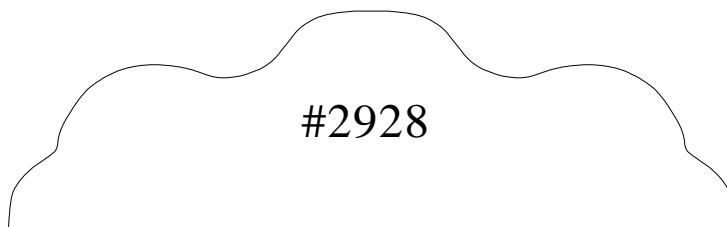
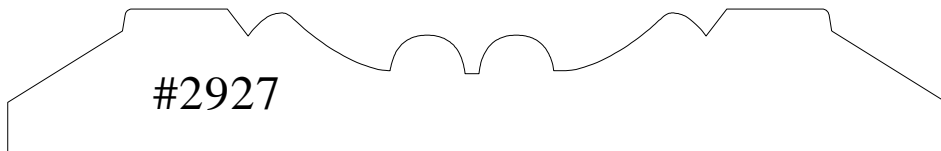
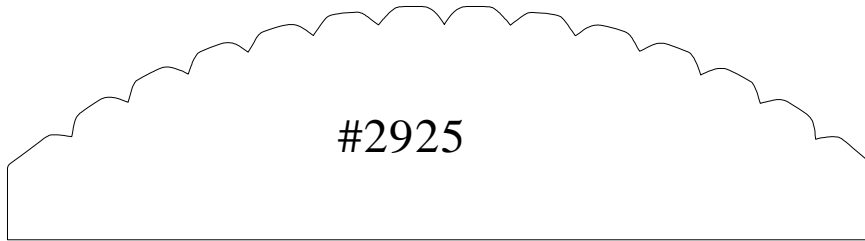

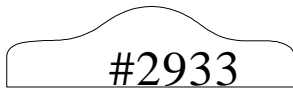
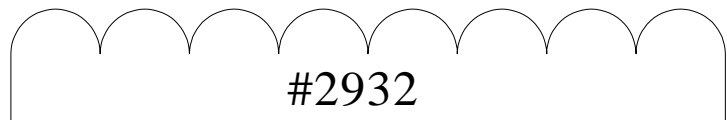
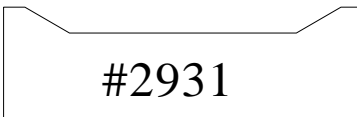
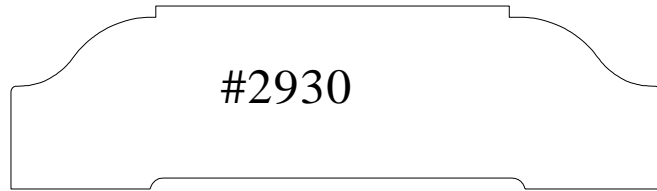
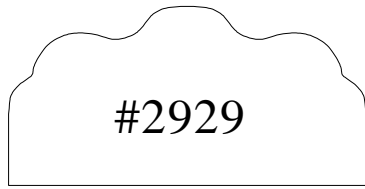

# Crown Pages

Crown mouldings sit at various angles to the wall and ceiling. The angles cut on the sides of the crown determines how far the crown will cover both down the wall and onto the ceiling.

You can often use base, case or flat stock behind a crown to give it an appearance of a much larger moulding.

Crown mouldings are difficult to modify.

Crown Page #1

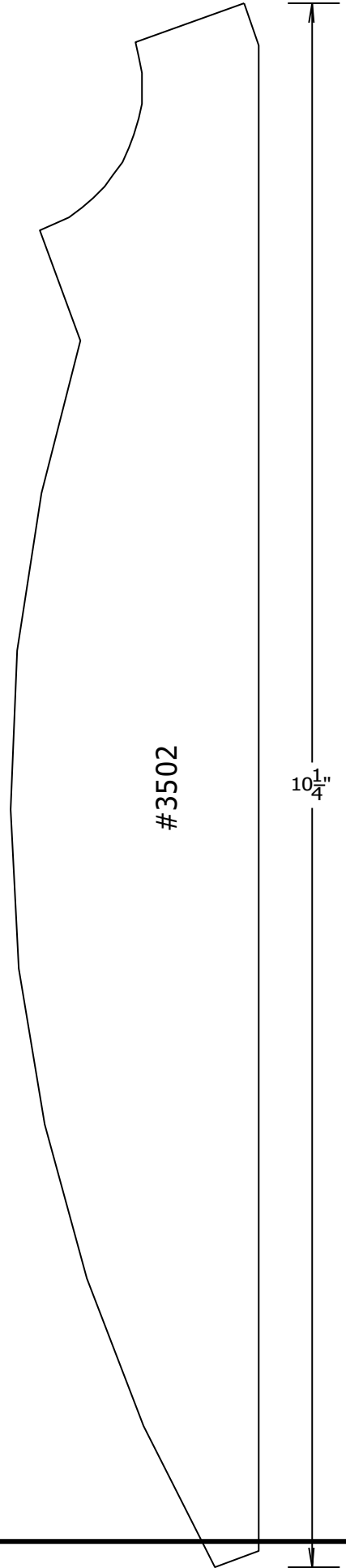
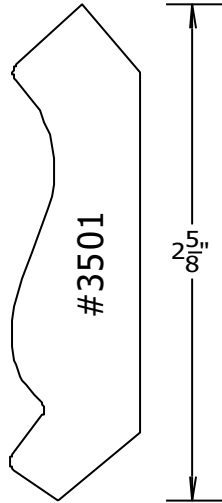
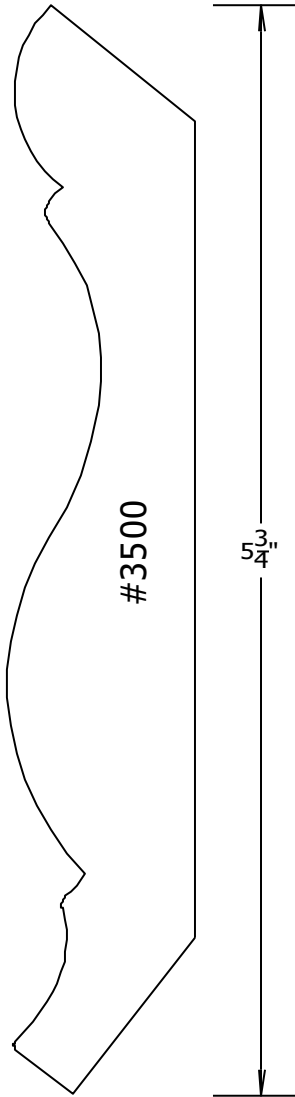

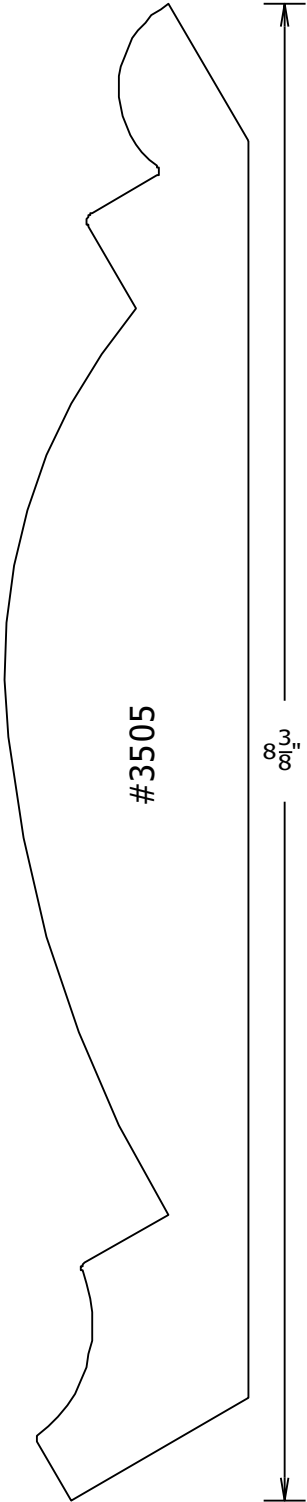
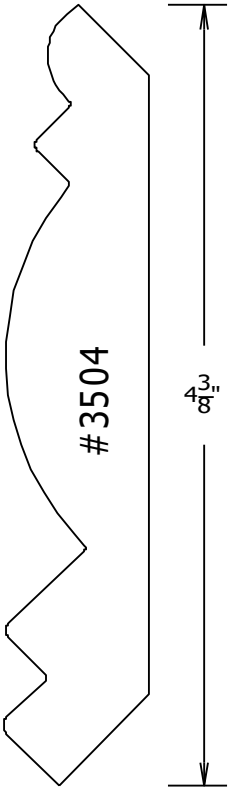
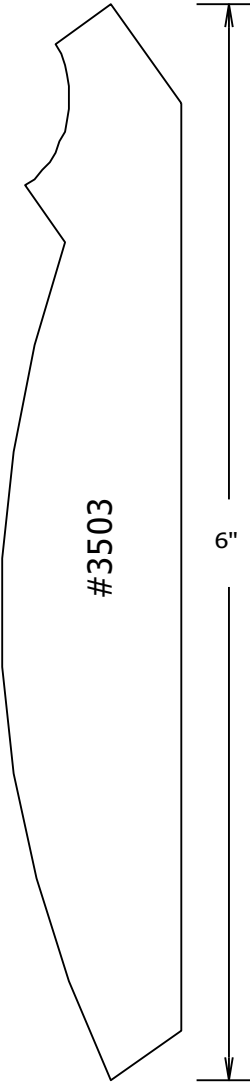

Crown Page #3

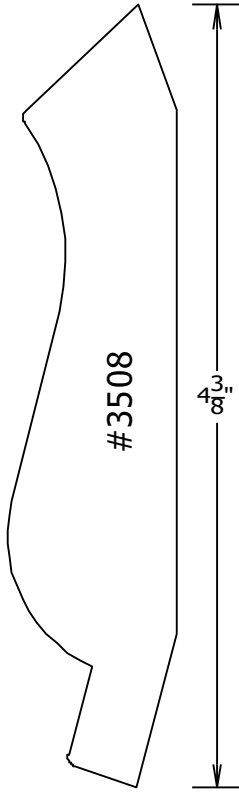
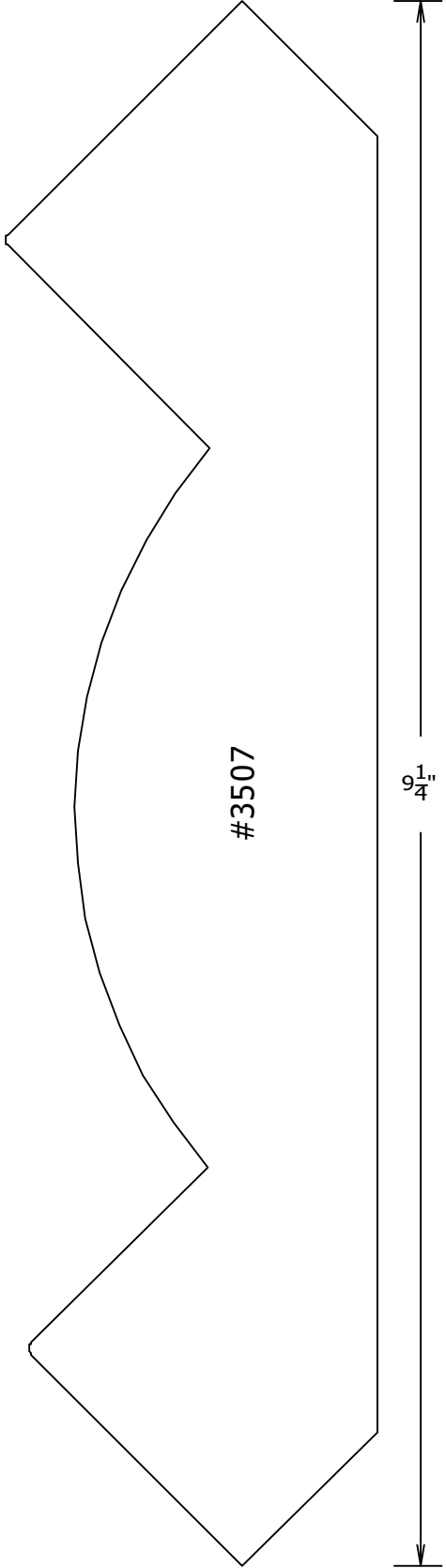
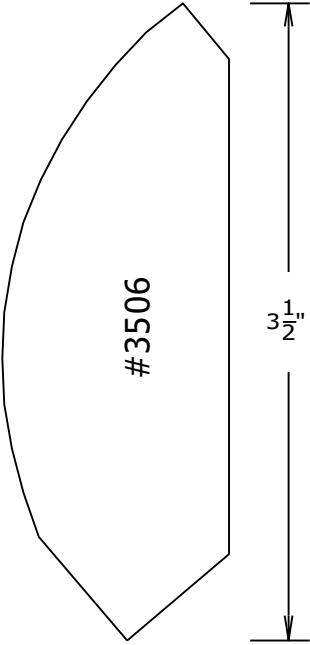

Crown Page #4

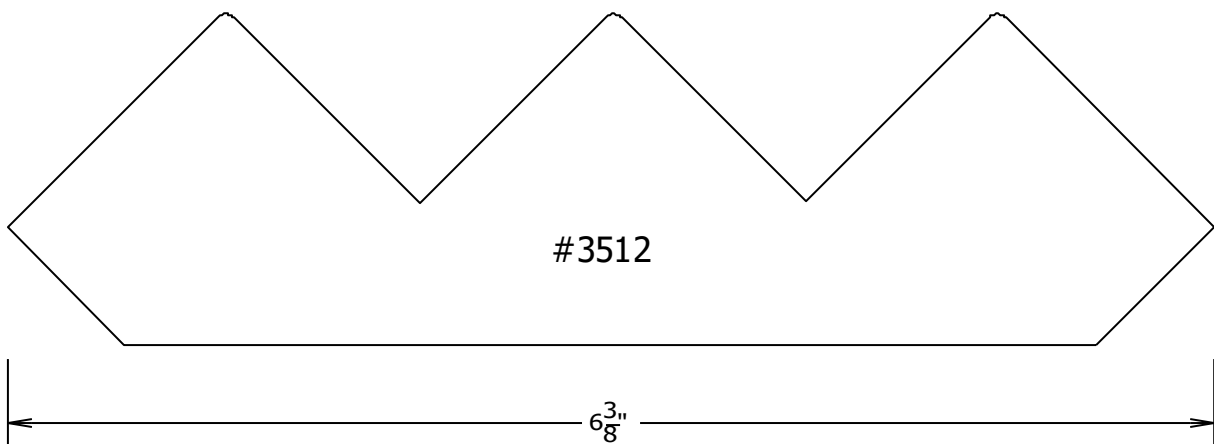
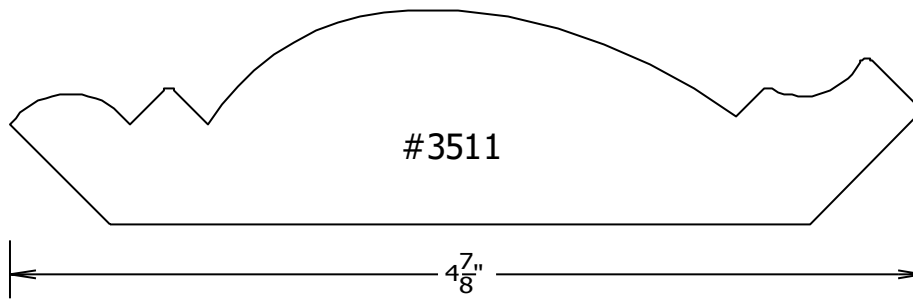
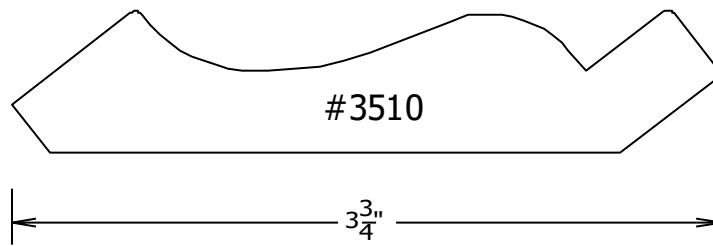
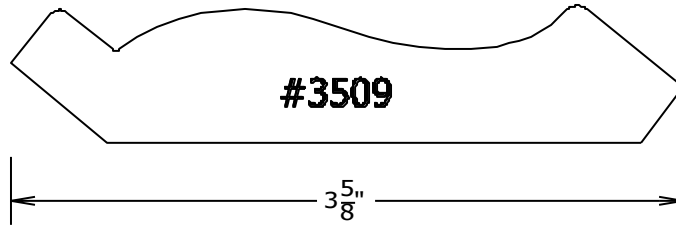



Crown Page #5

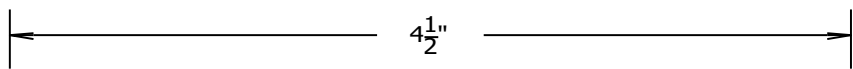
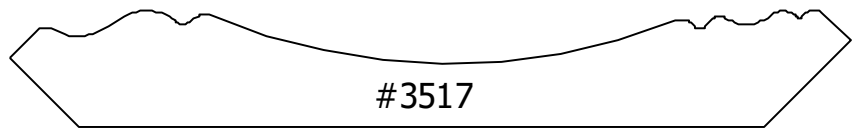
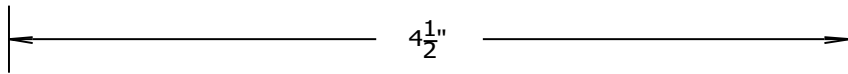
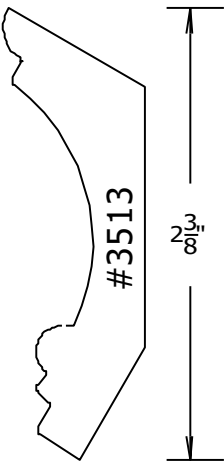
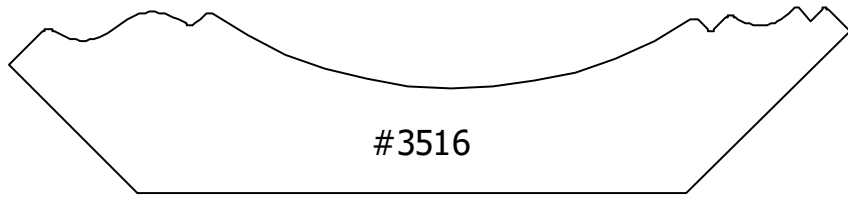
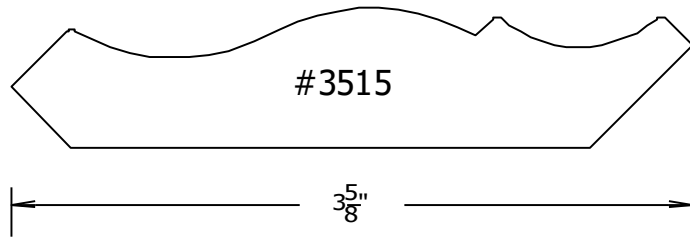
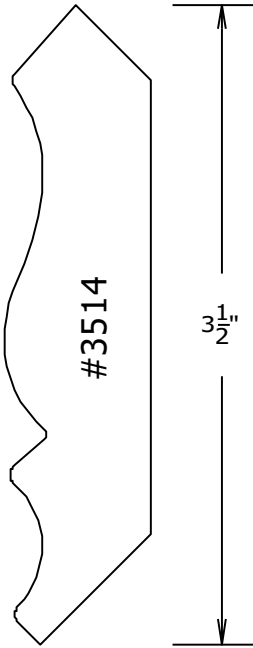

Crown Page #6

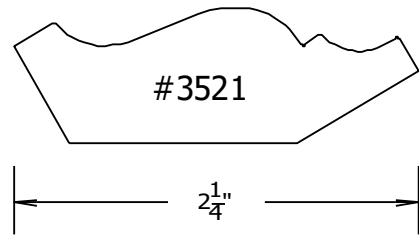
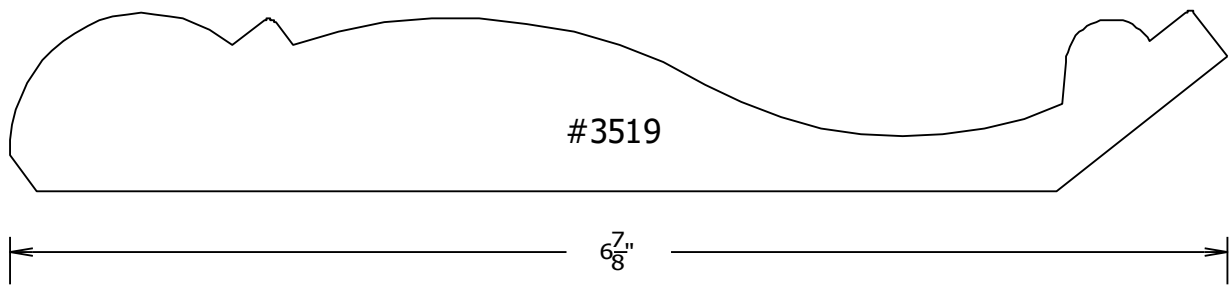
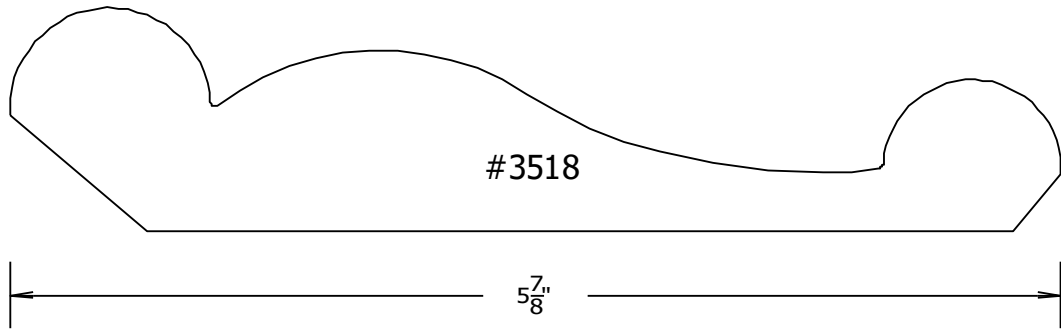

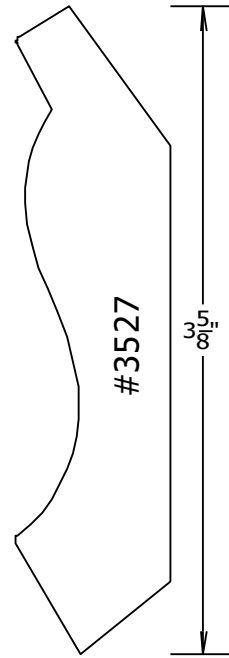
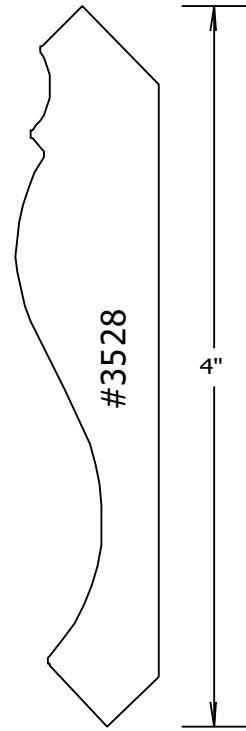
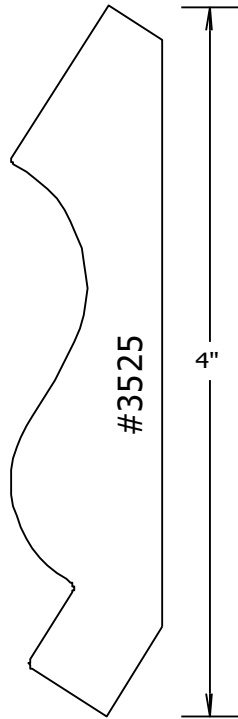
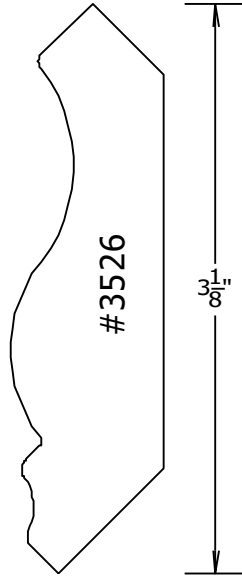
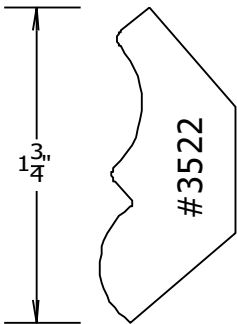
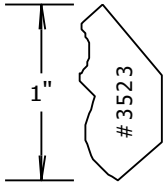
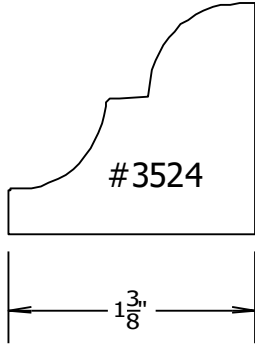

Crown Page #8

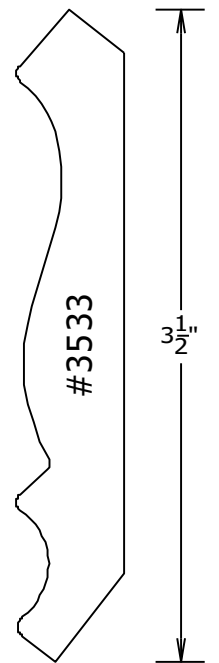
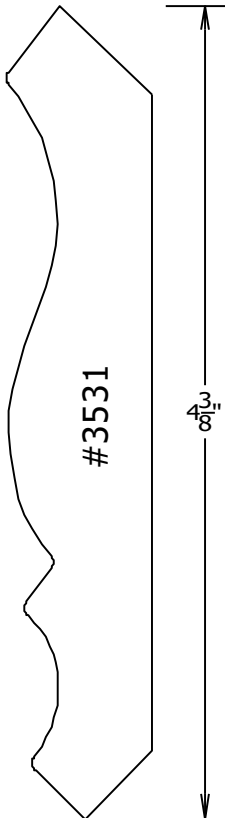
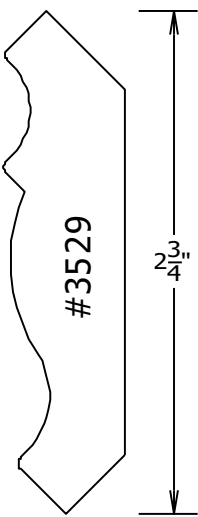
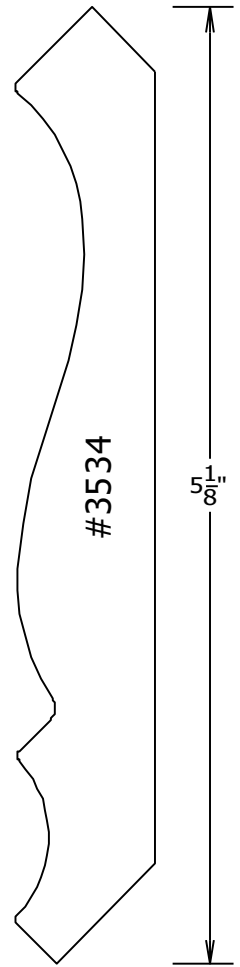
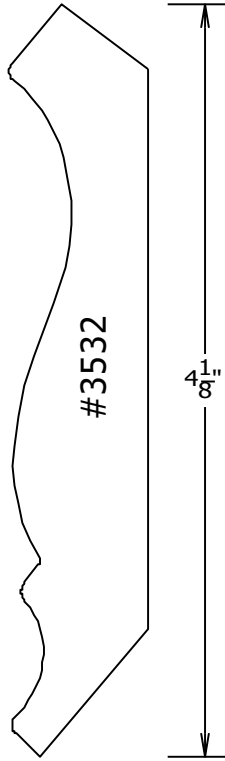
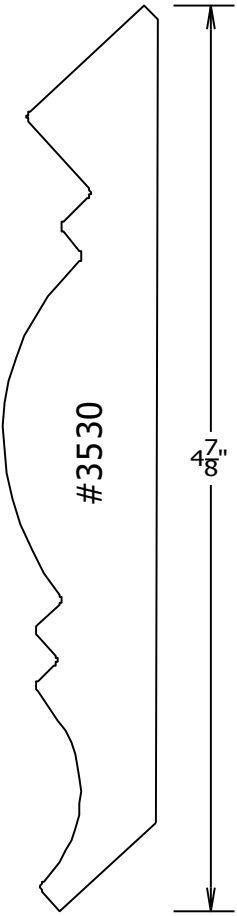

Crown Page #9

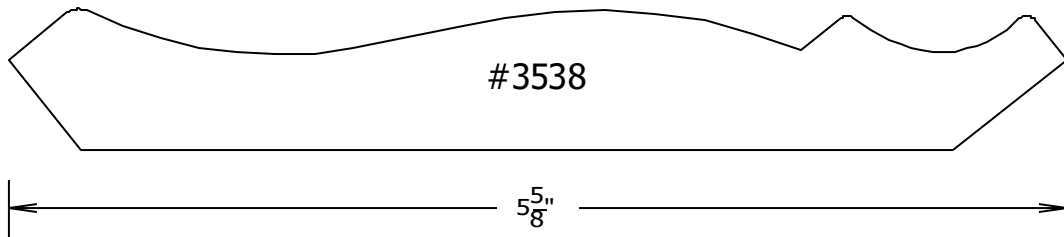
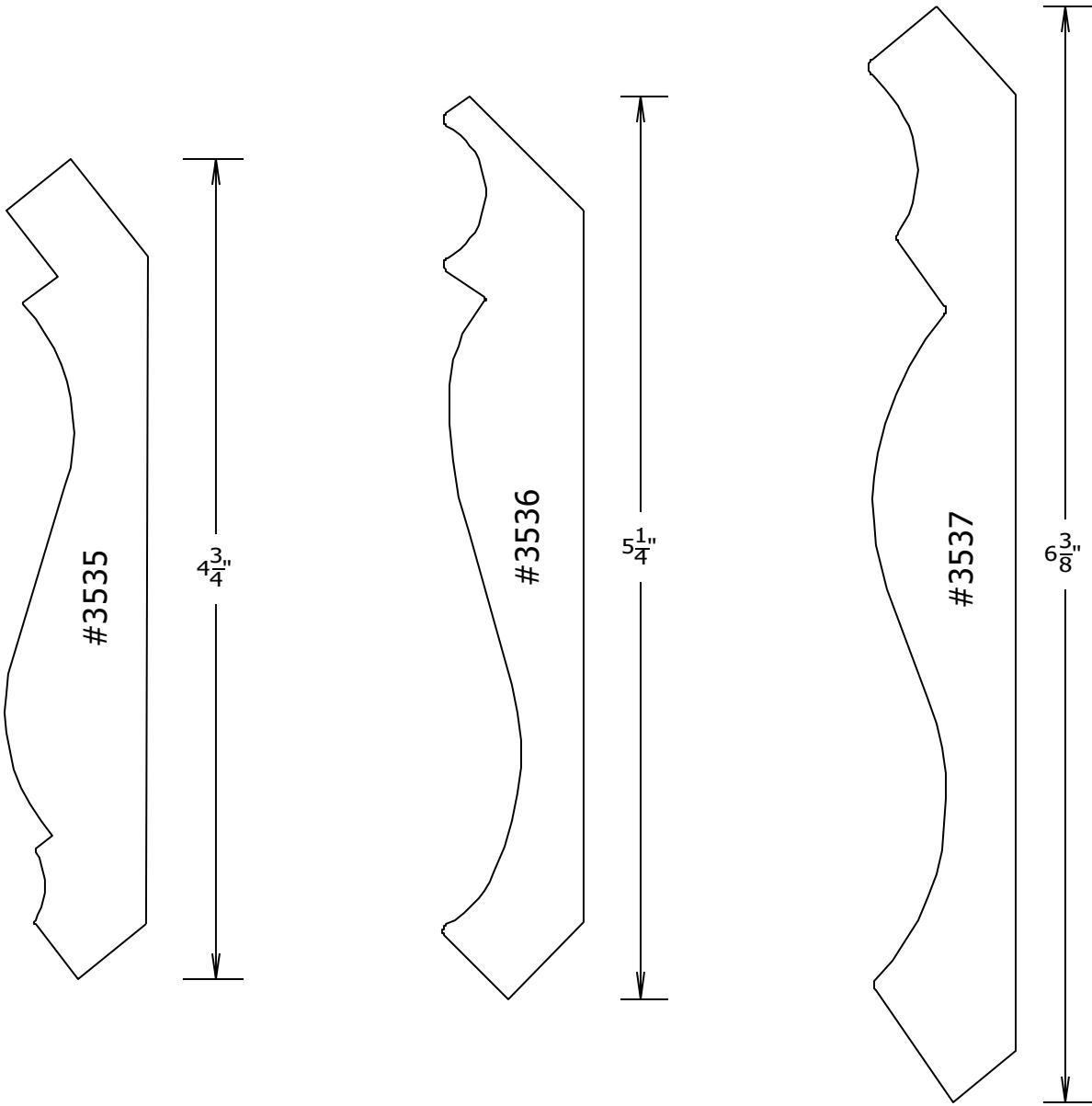

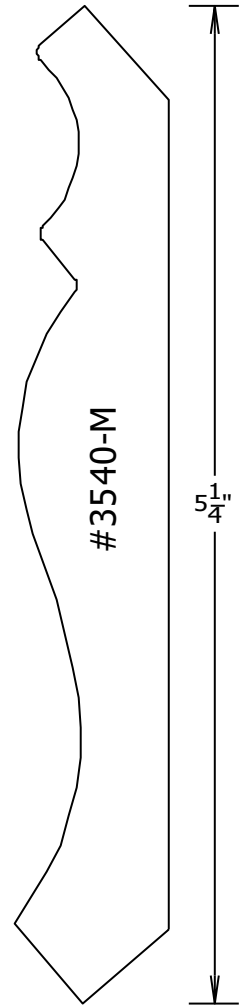
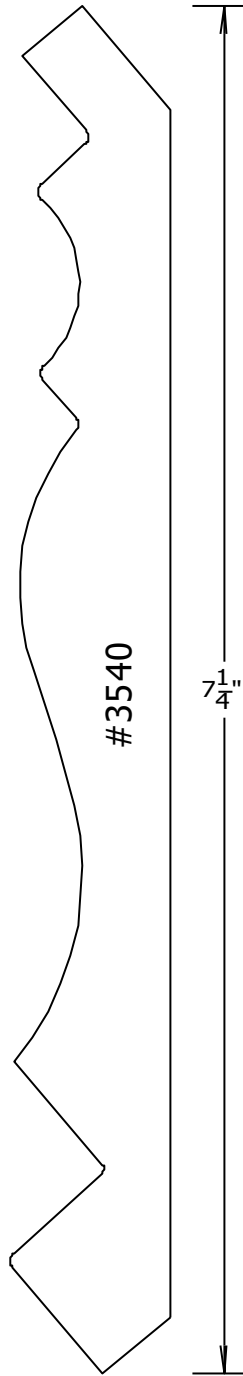

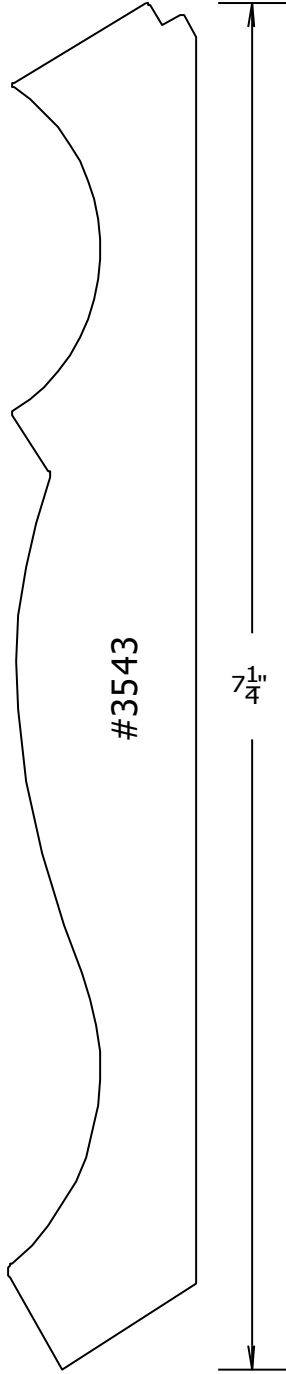
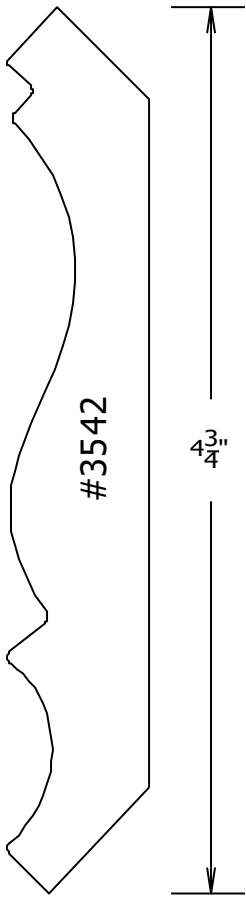
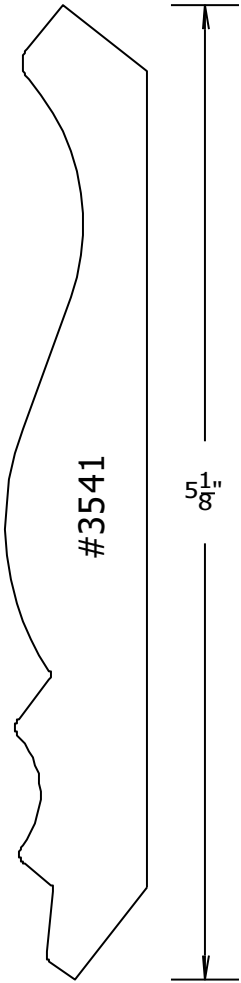

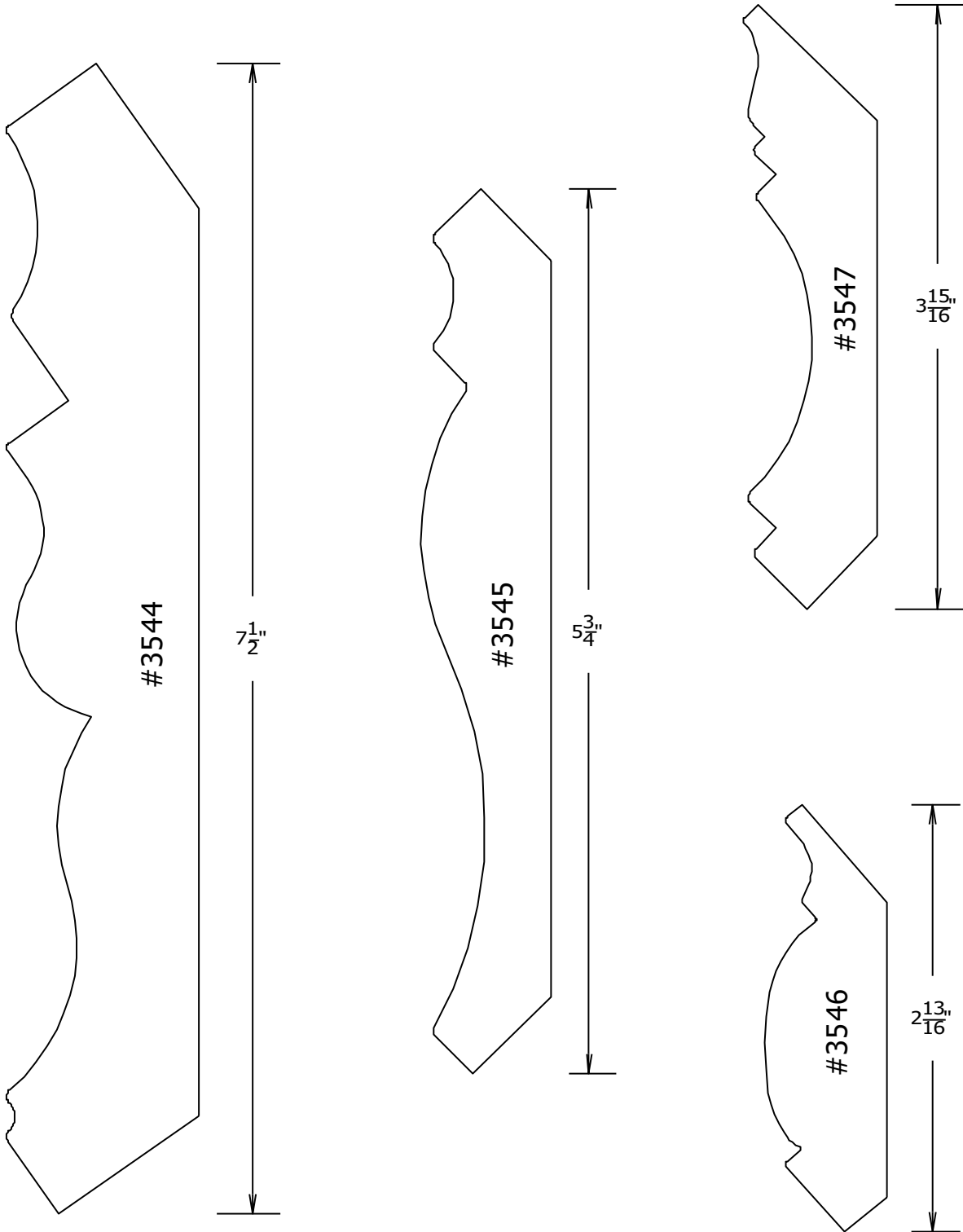



Crown Page #13

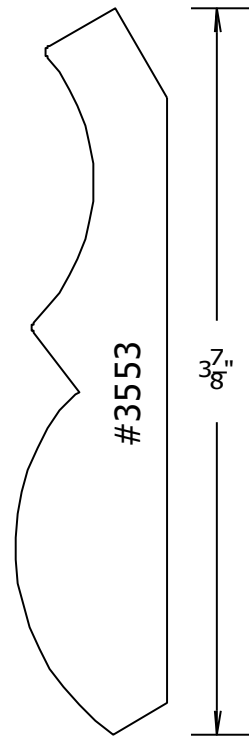
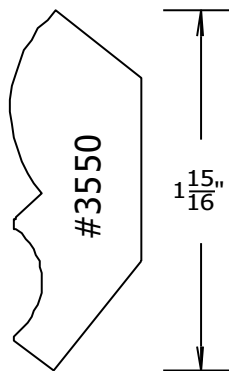
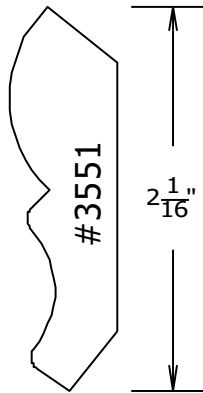
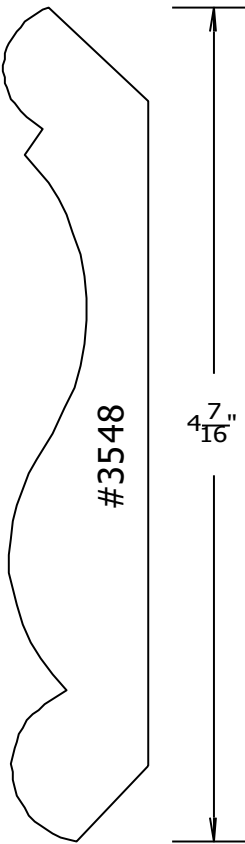
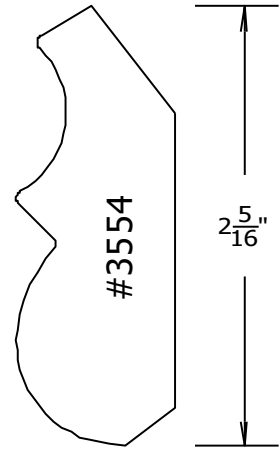
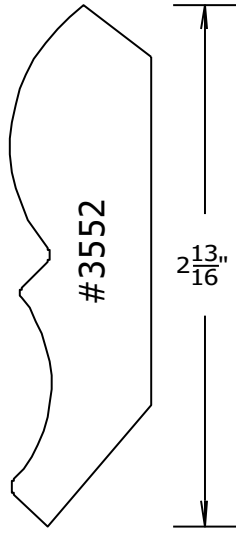
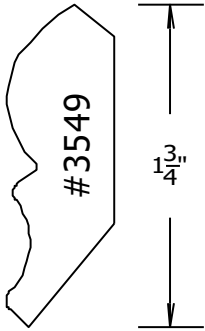

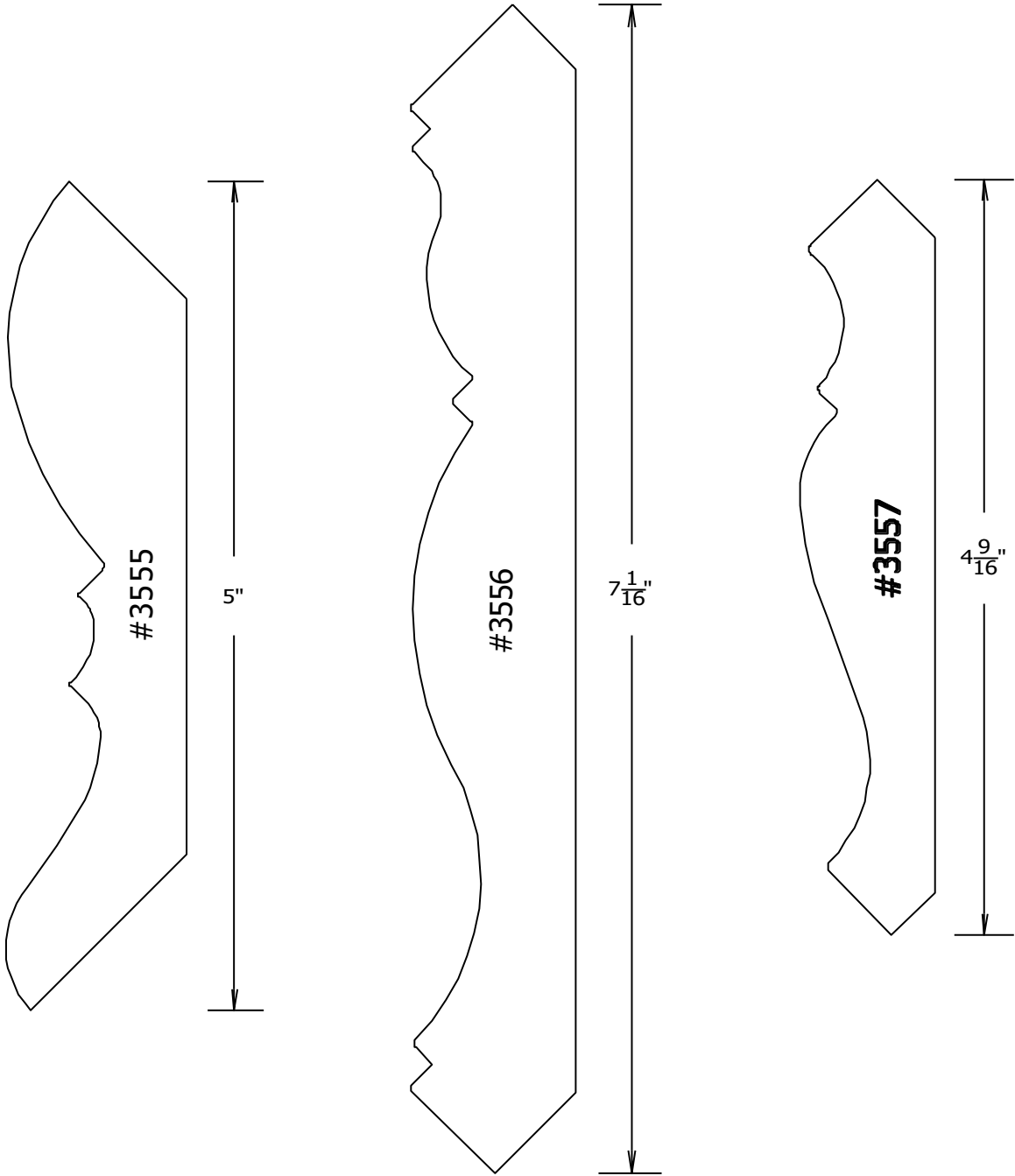

Crown Page #15

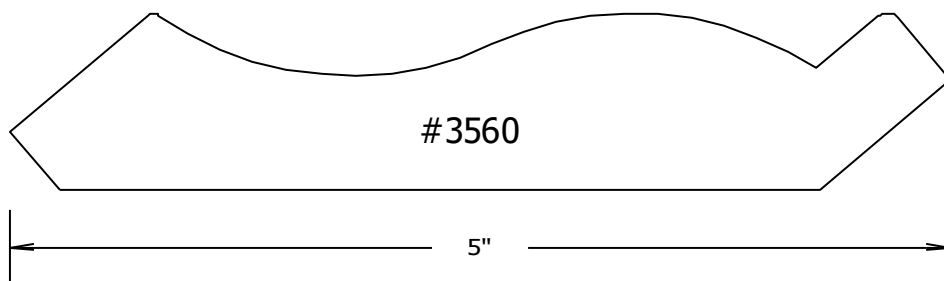
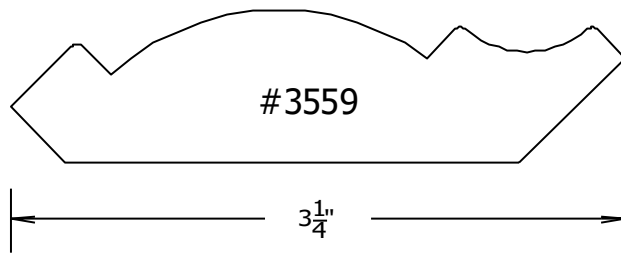
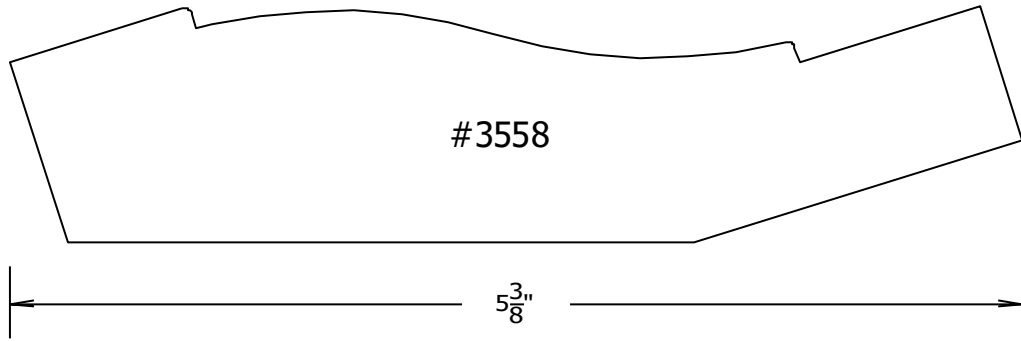

Crown Page #16

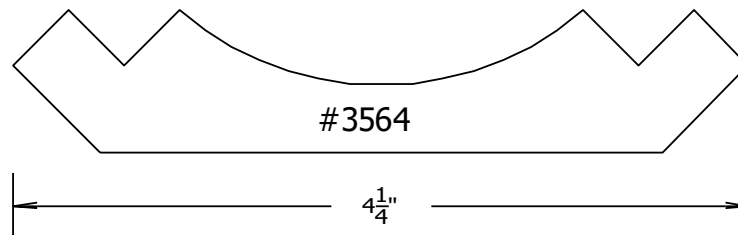
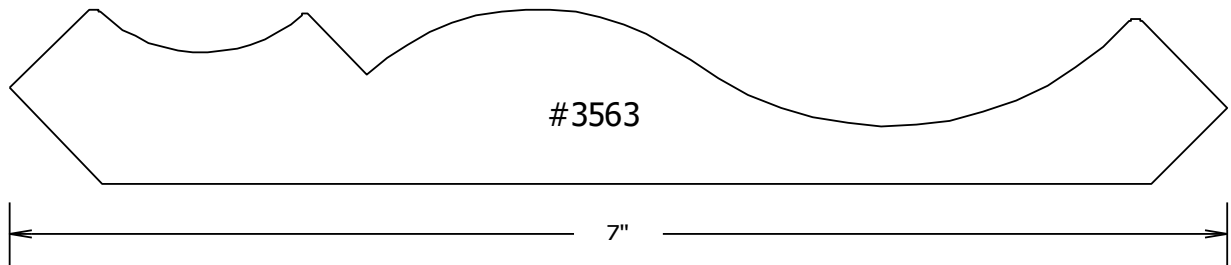
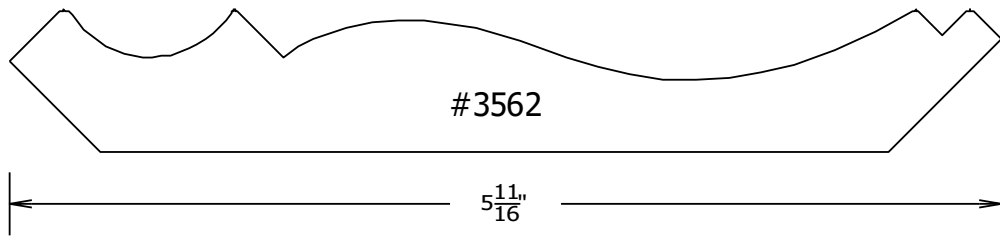
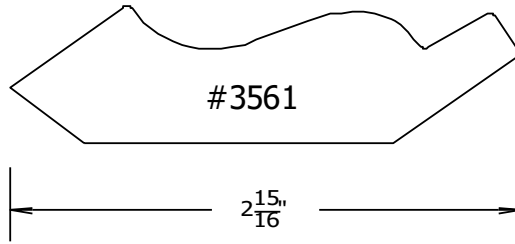

Crown Page #17

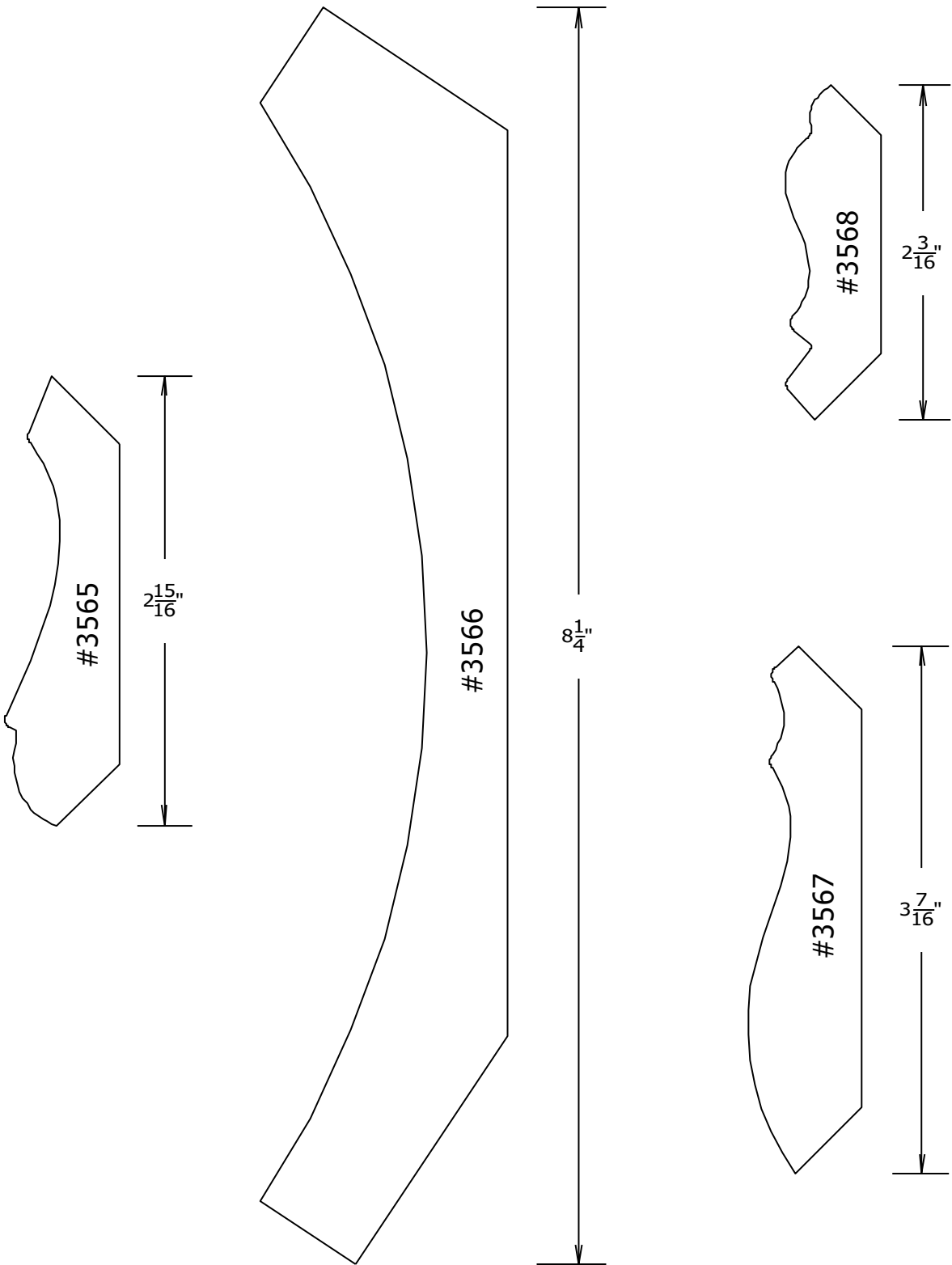

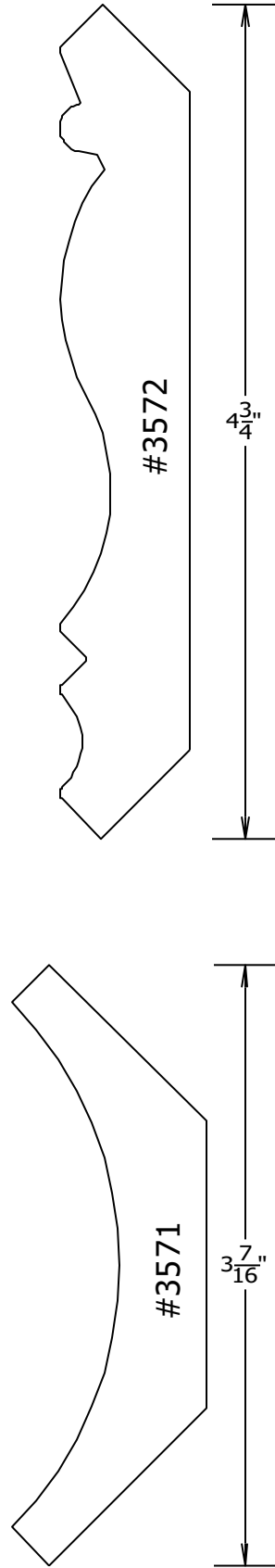
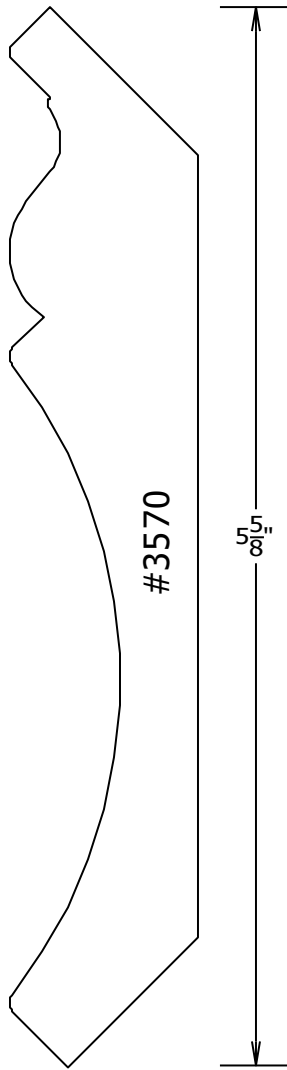
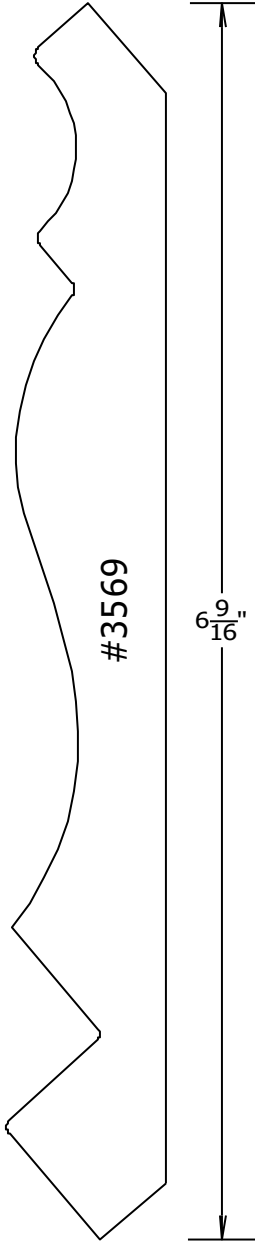

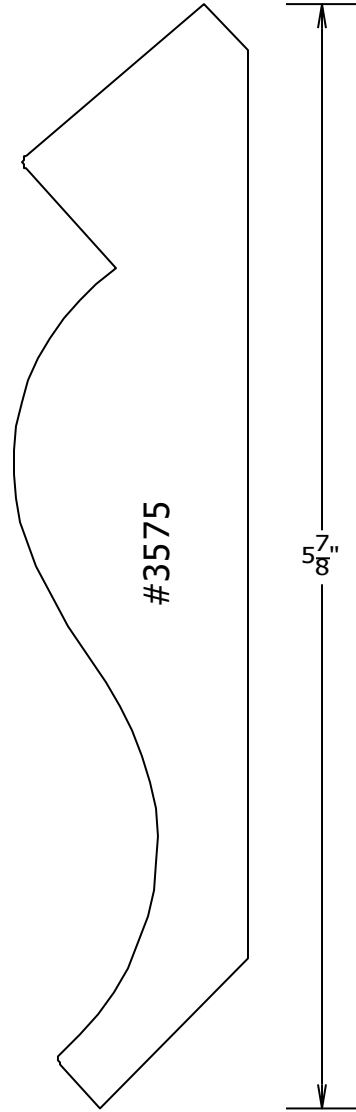
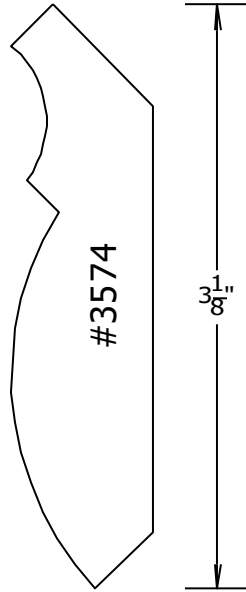
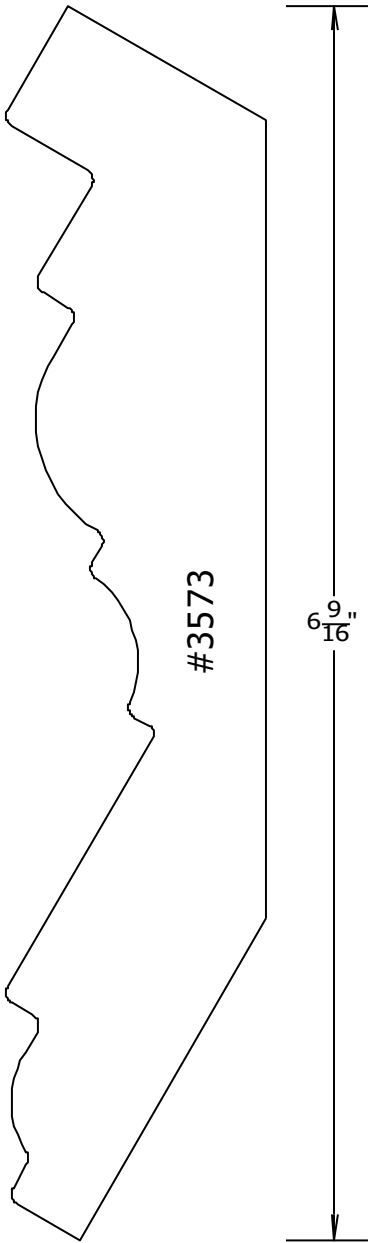

Crown Page #20

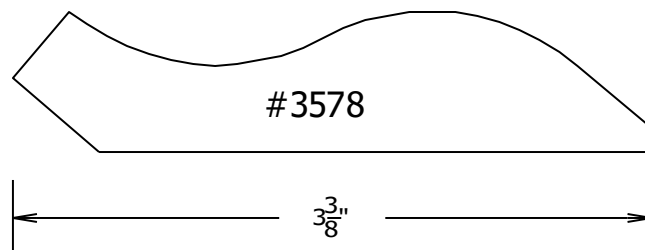
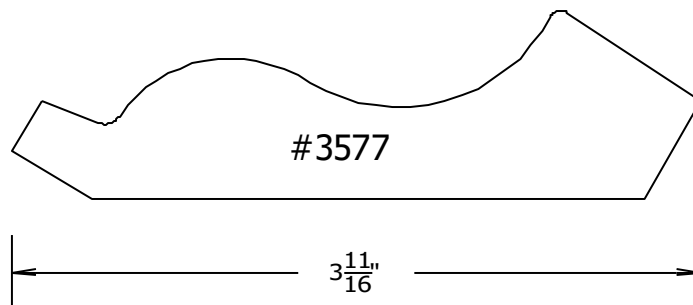
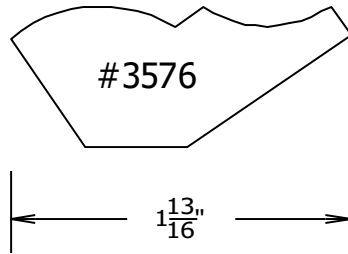



Crown Page #21

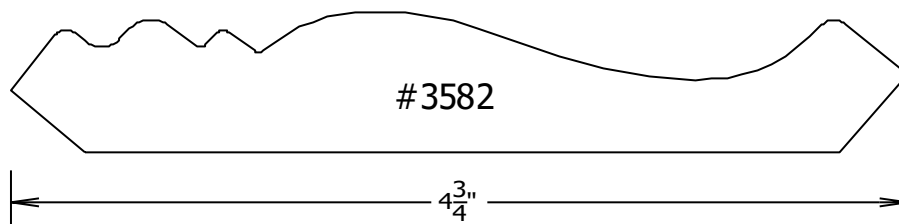
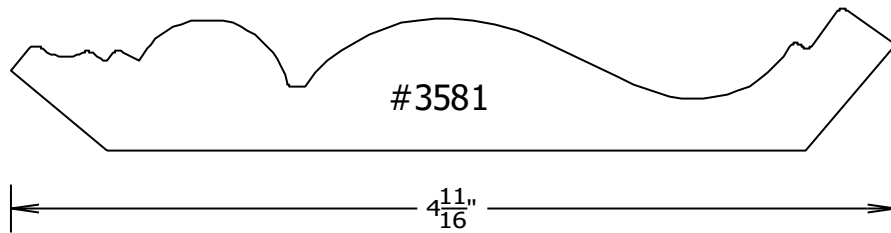
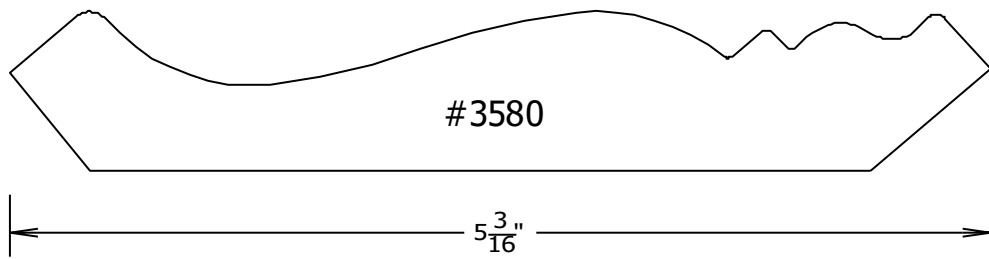
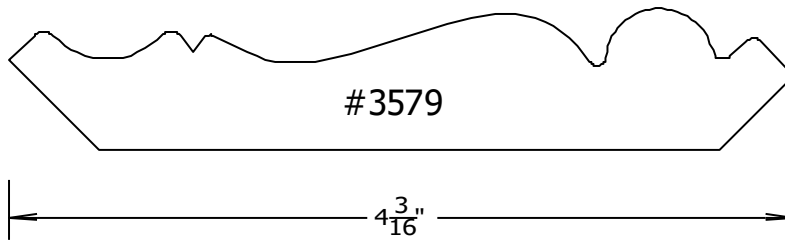

Crown Page #22

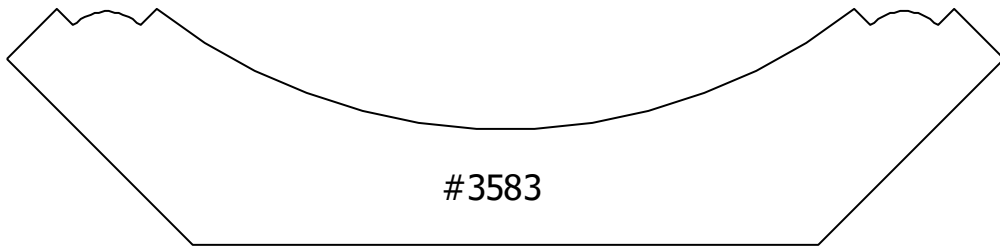

#3583

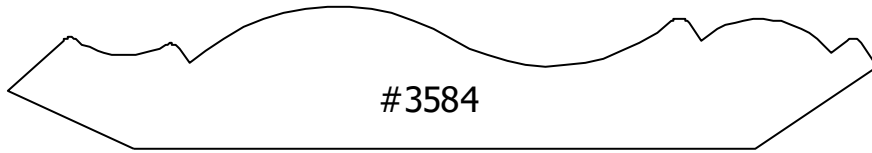
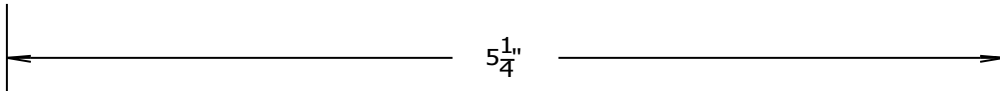

#3584

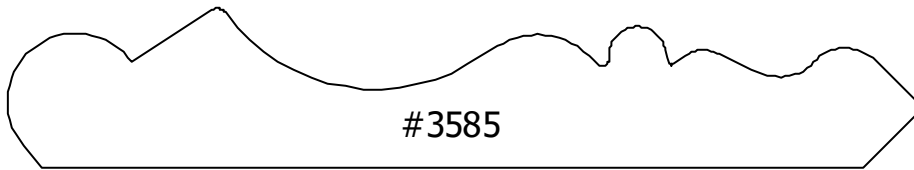
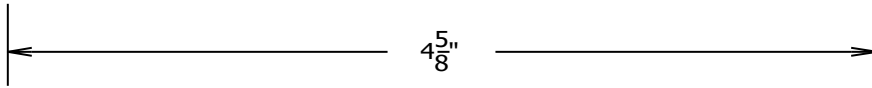

#3585

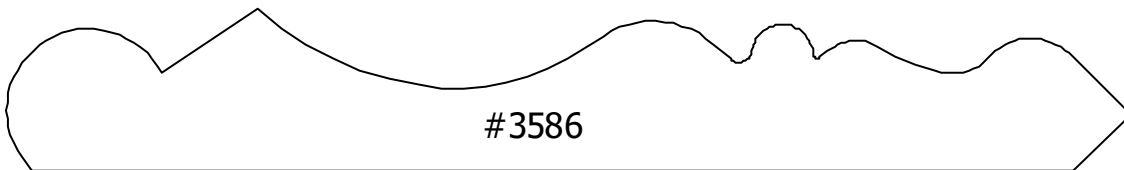
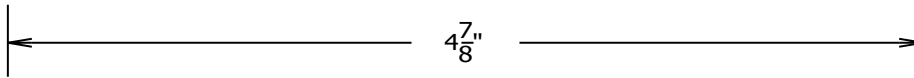

#3586

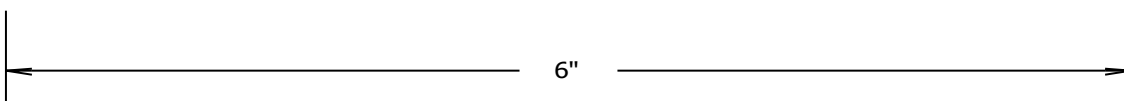

Crown Page #23

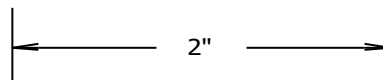
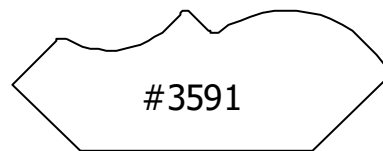
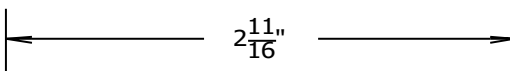
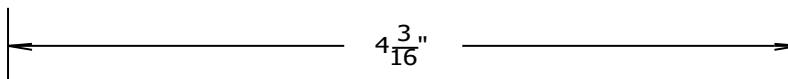
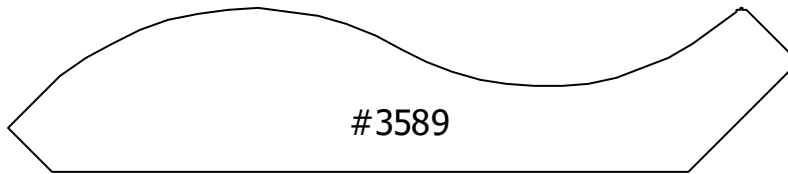
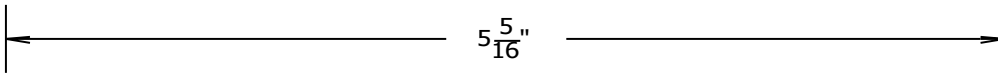
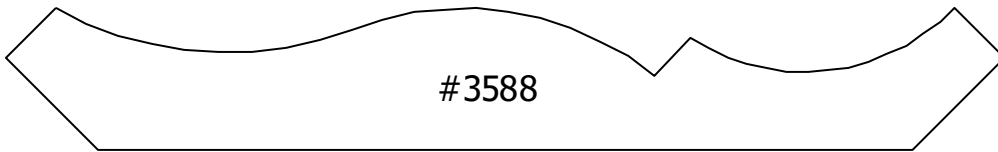
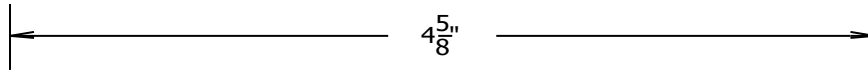
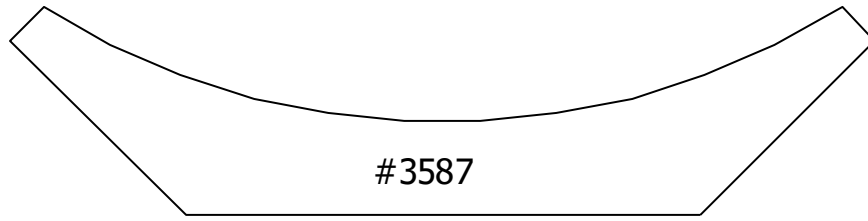

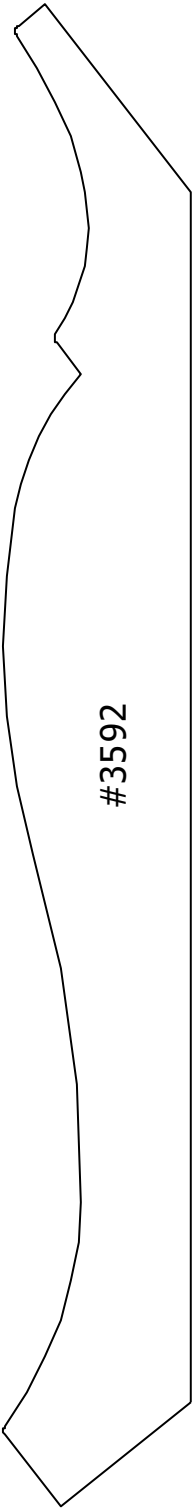

#3592

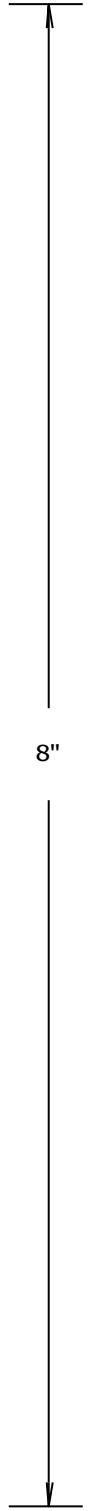

8"

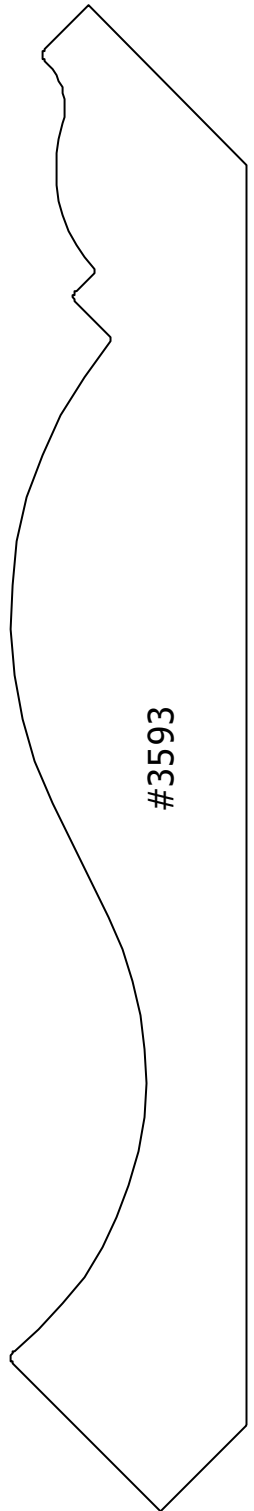

#3593

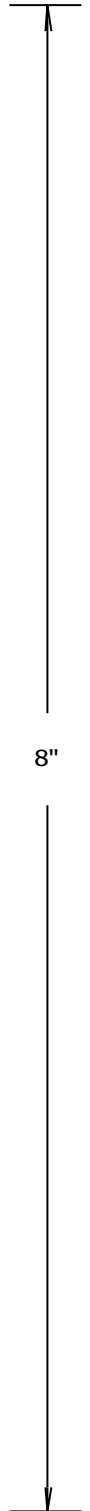

8"

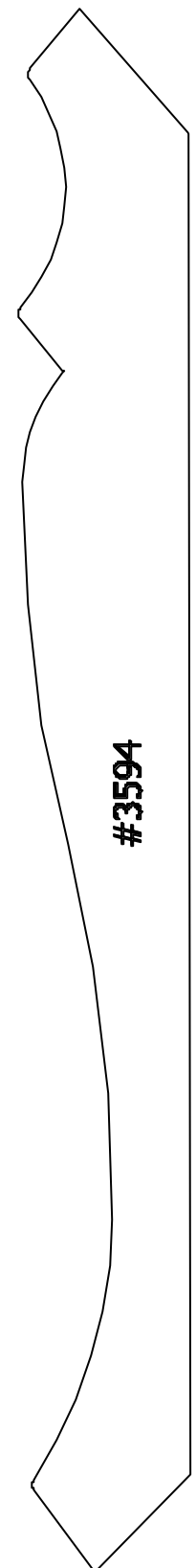

#3594

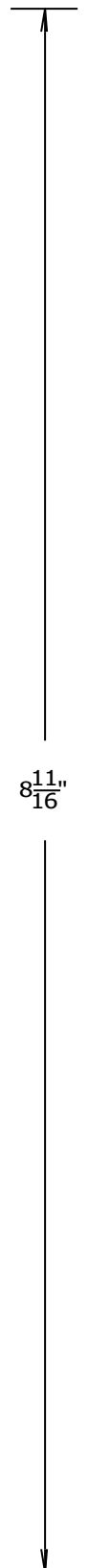

8 <sup>11</sup>/<sub>16</sub>"

Crown Page #25

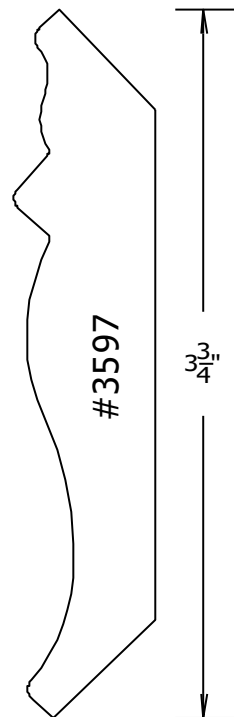
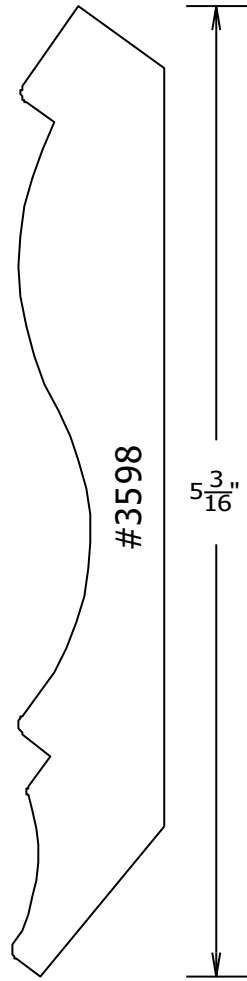
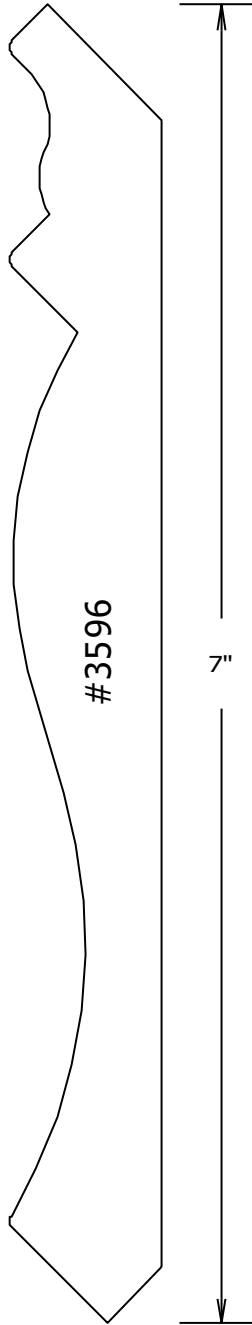
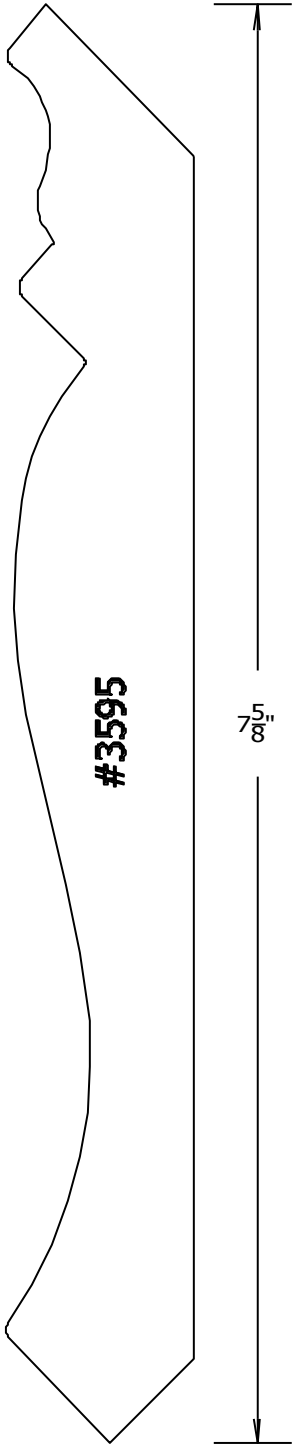

Crown Page #26

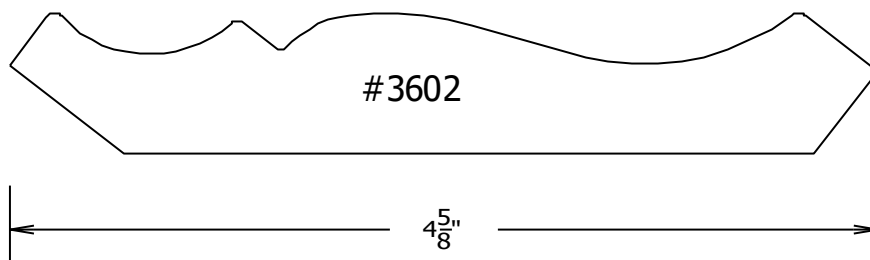
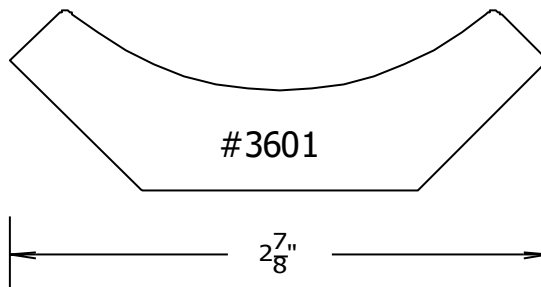
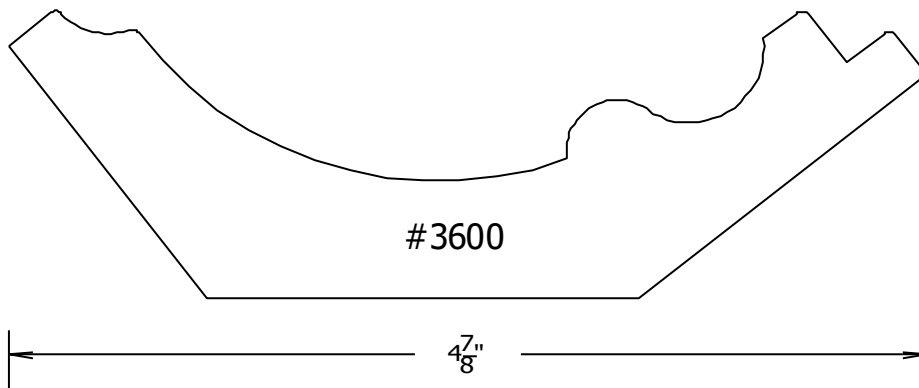
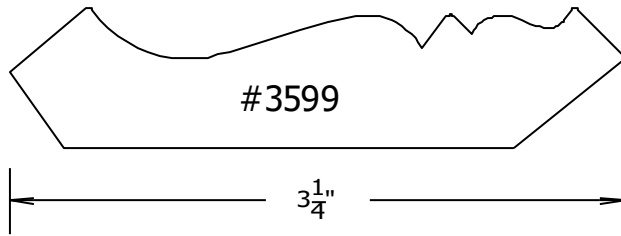

Crown Page #27

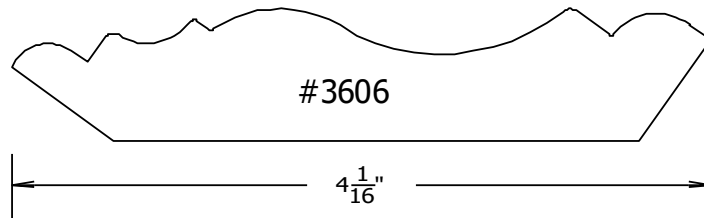
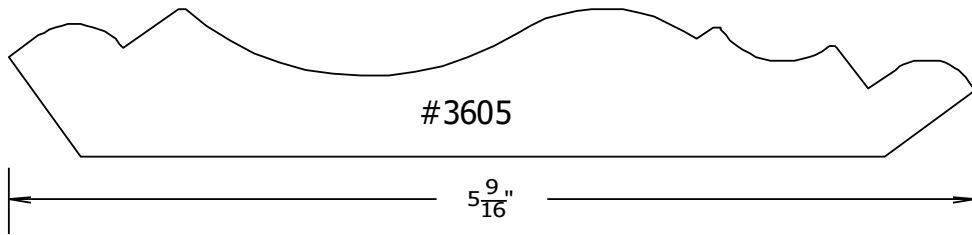
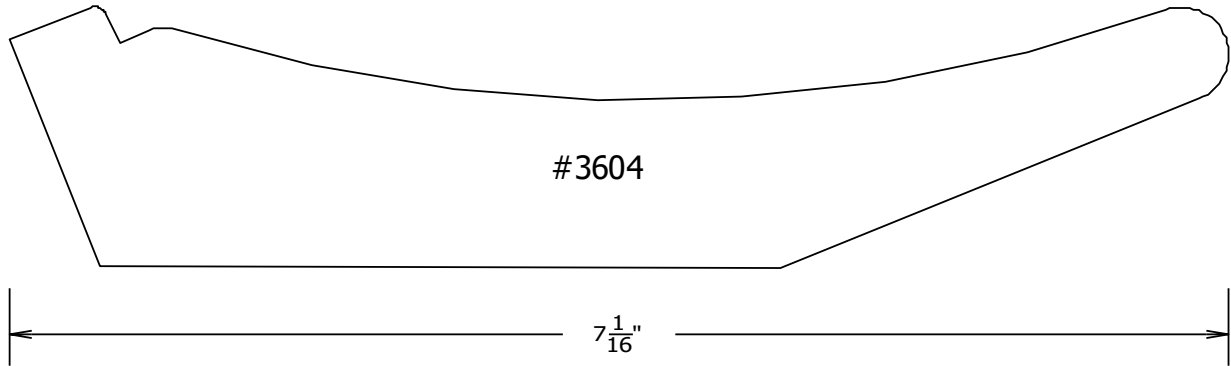
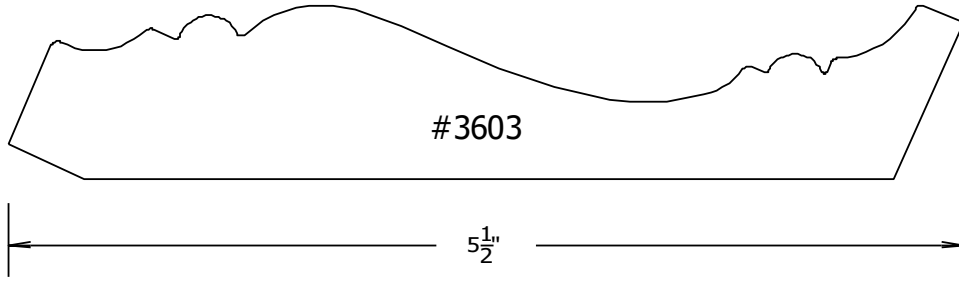

Crown Page #28

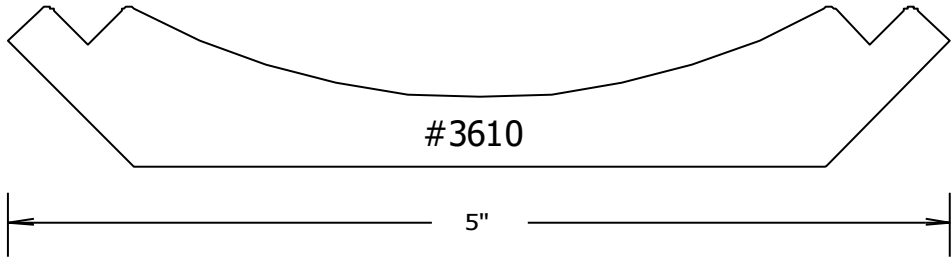
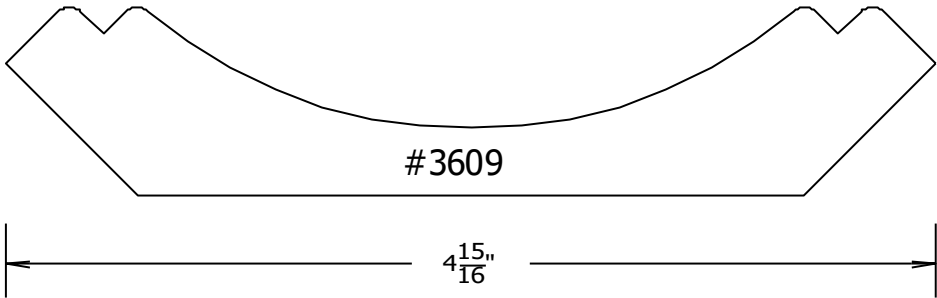
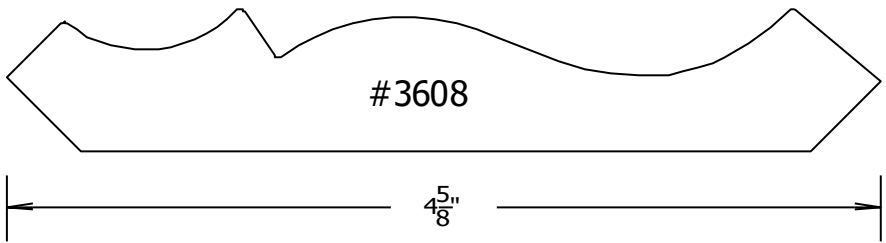
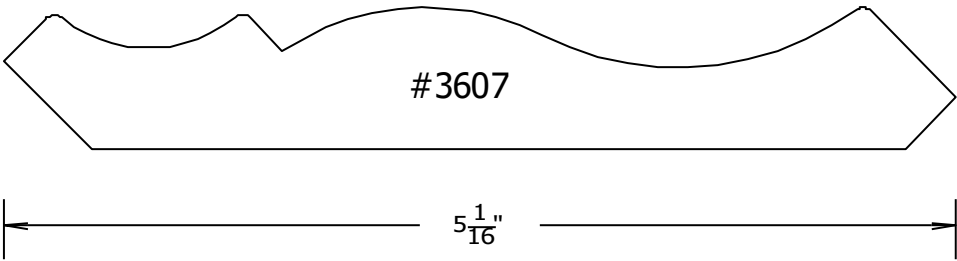



Crown Page #29

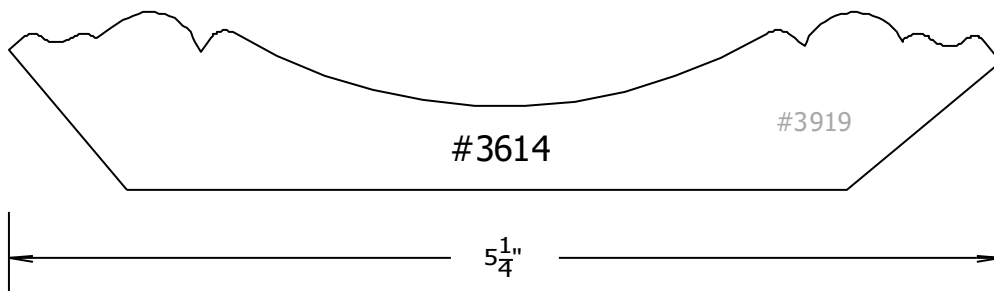
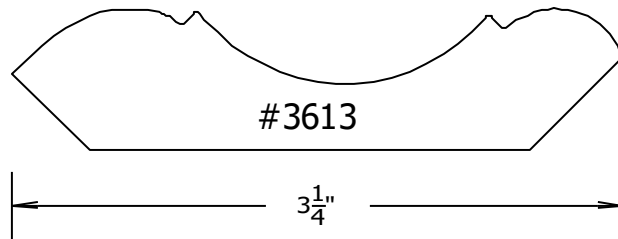
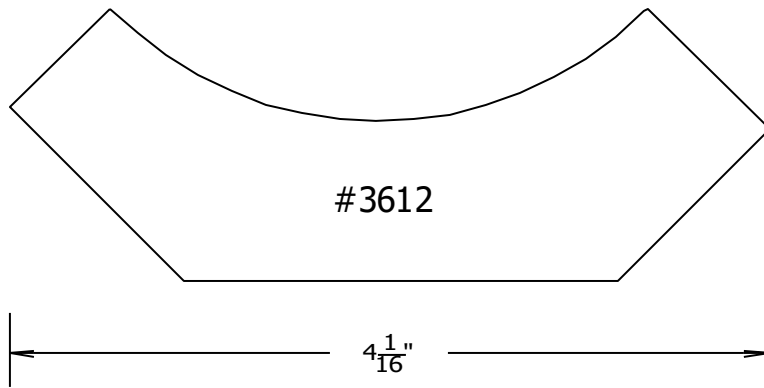
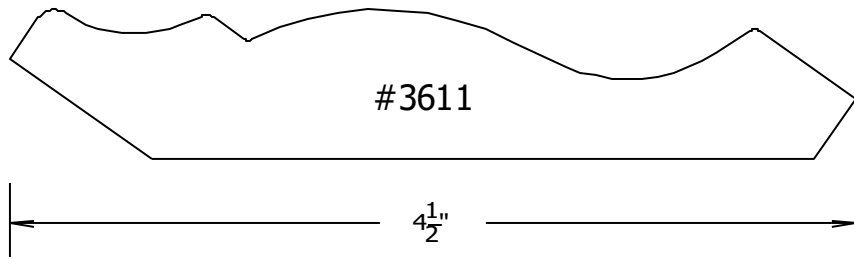

Crown Page #30

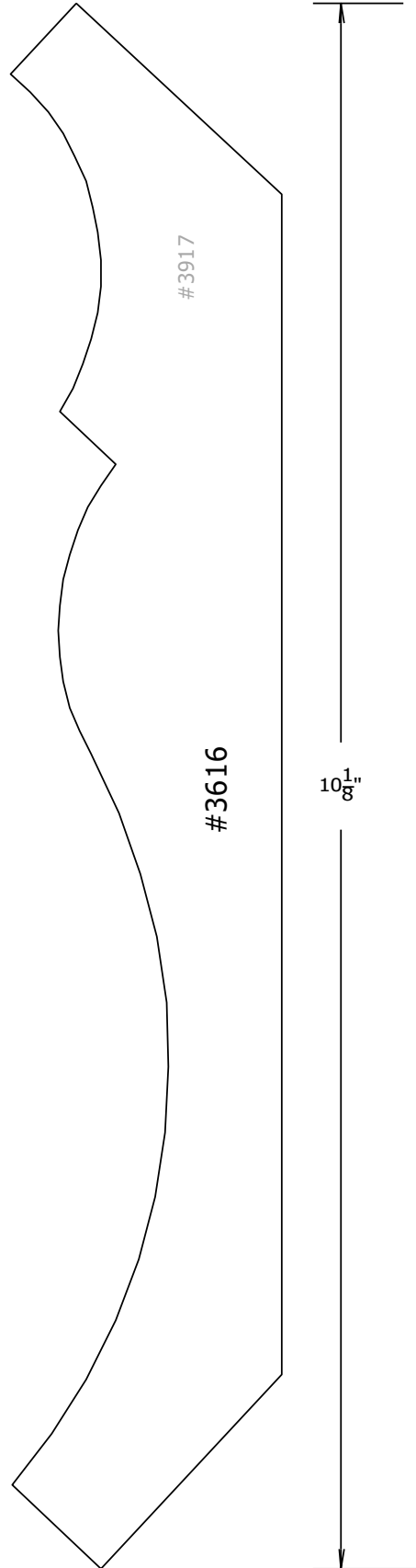
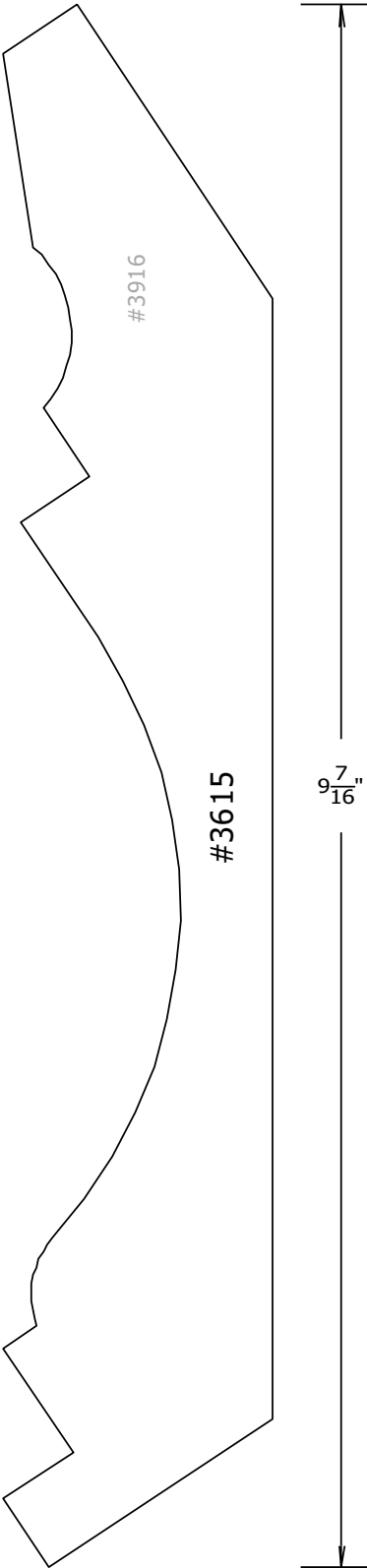

Crown Page #31

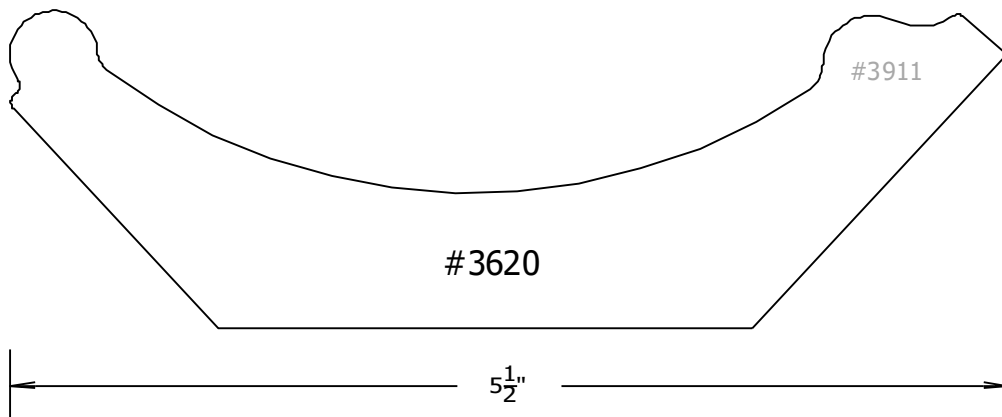
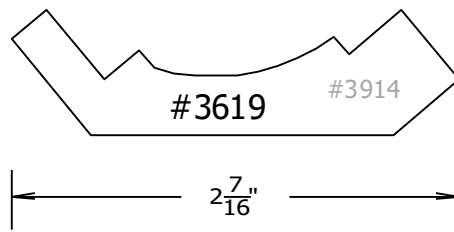
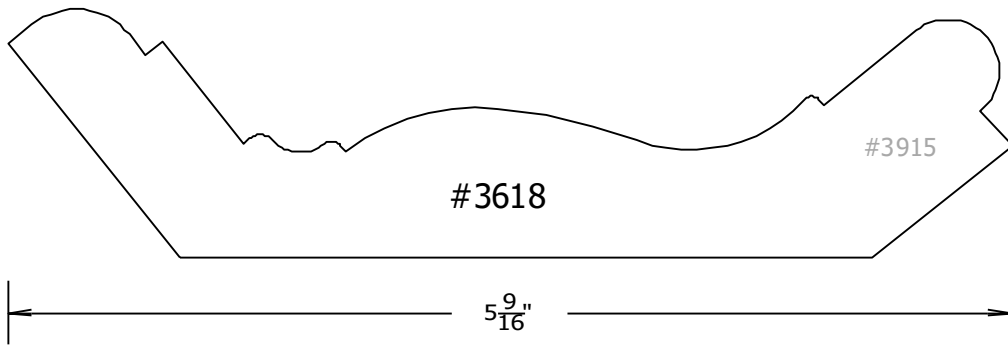
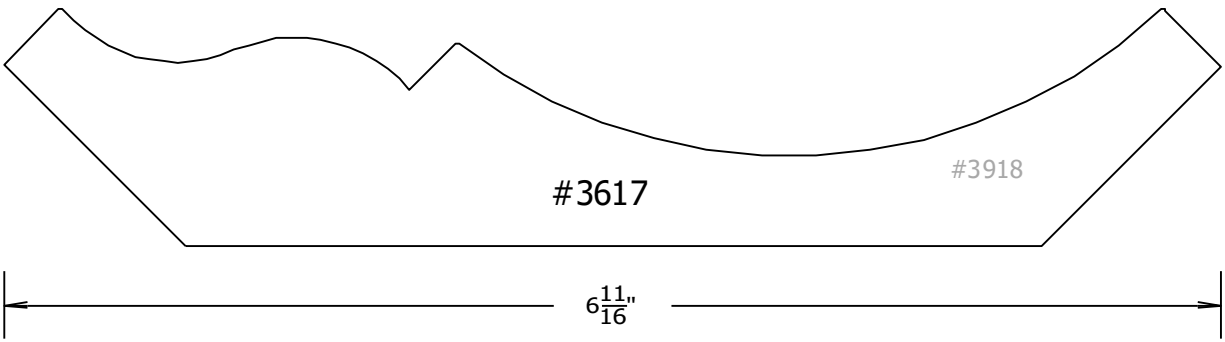

Crown Page #32

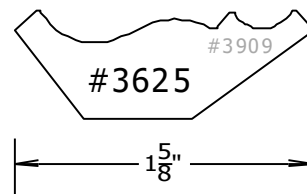
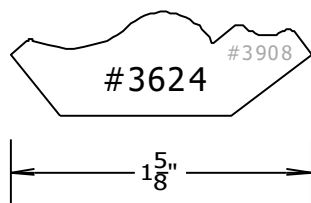
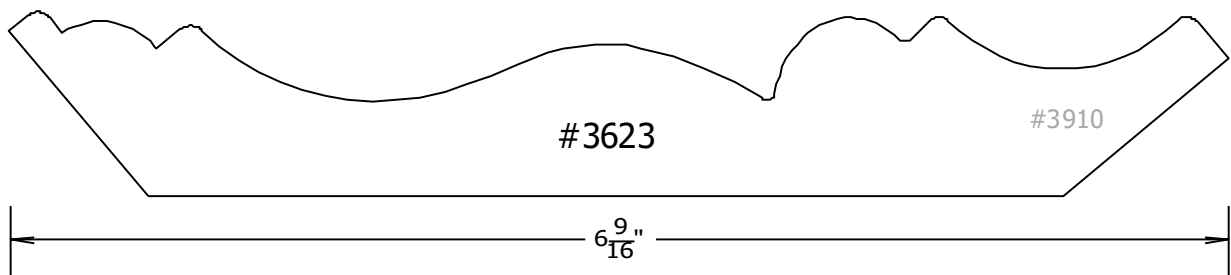
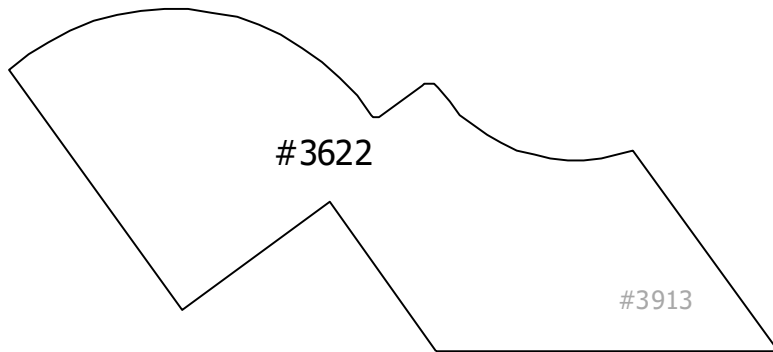
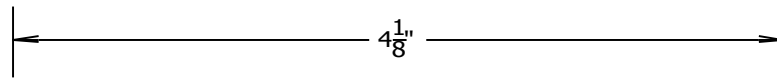
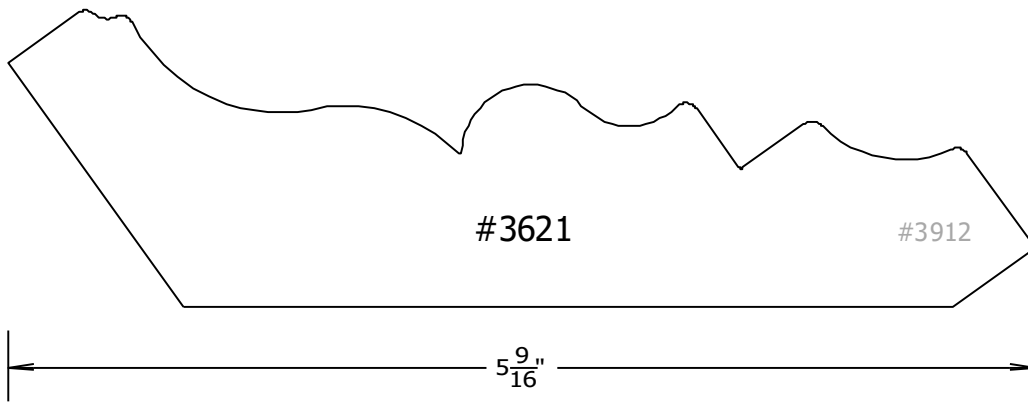

Crown Page #33

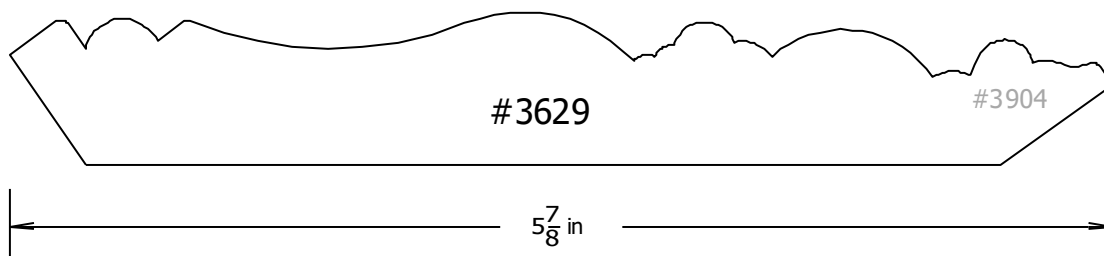
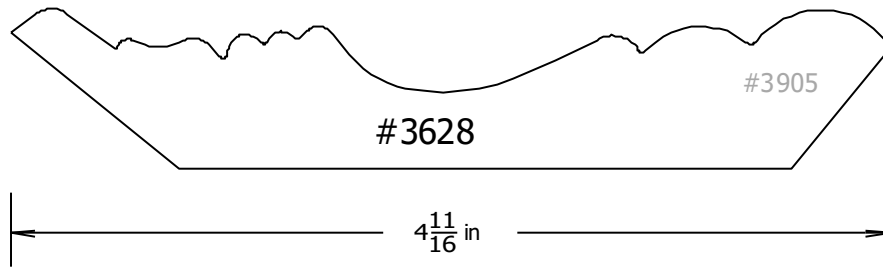
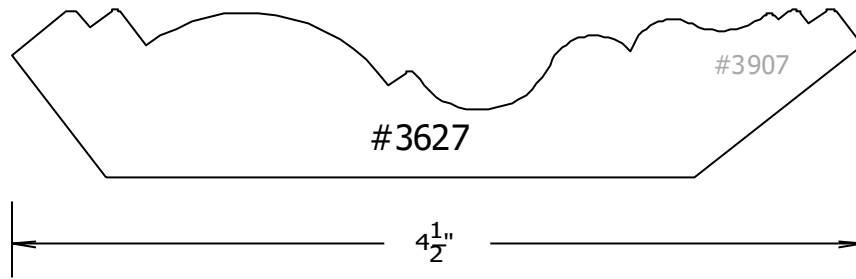
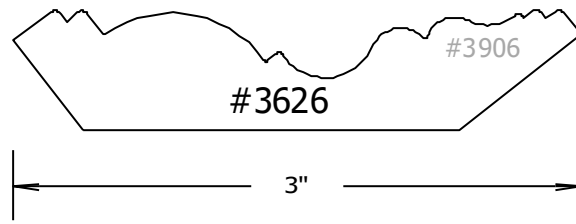

Crown Page #34

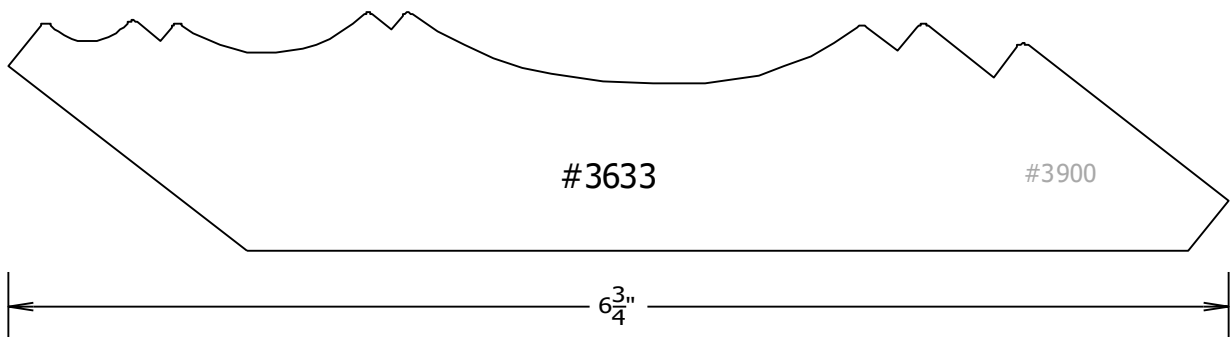
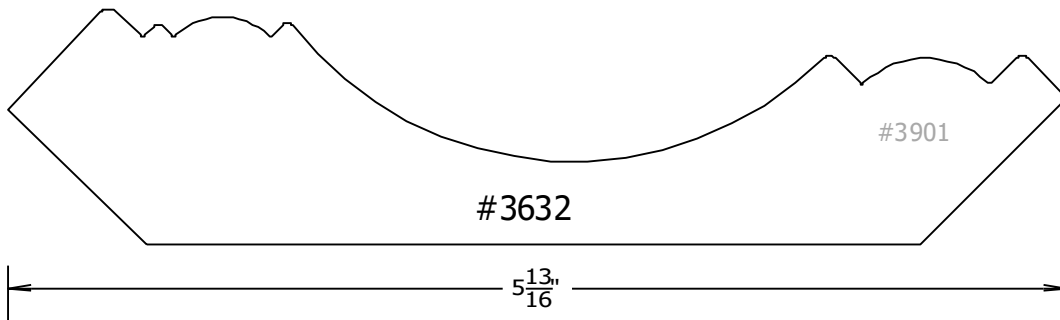
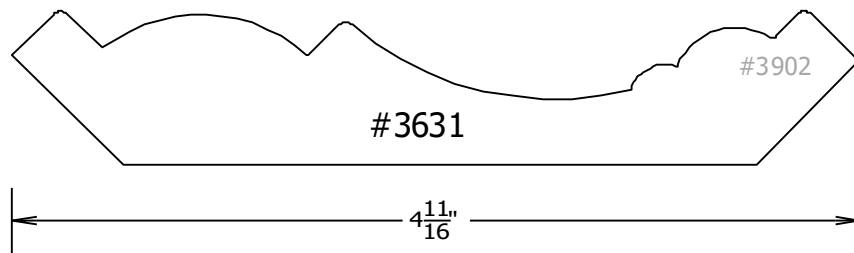
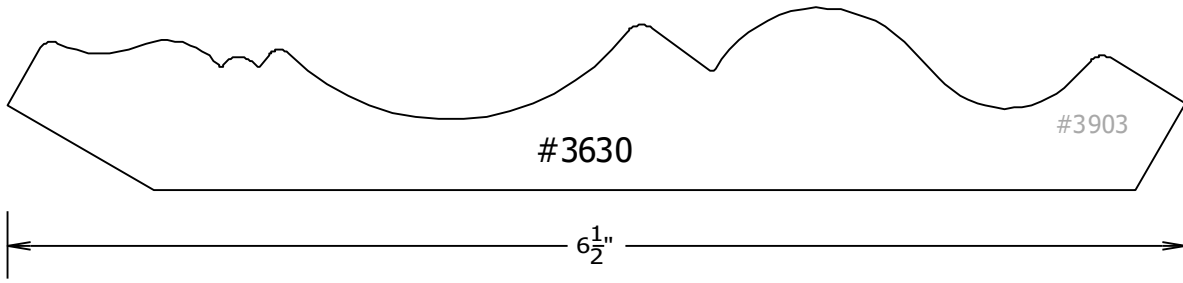

Crown Page #35

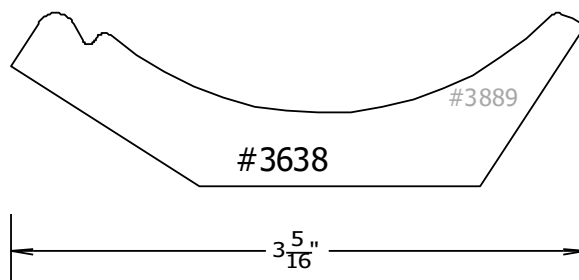
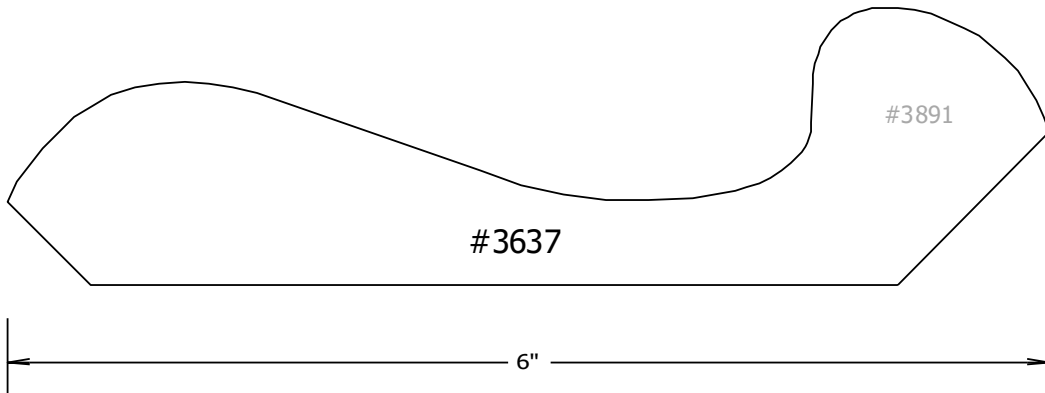
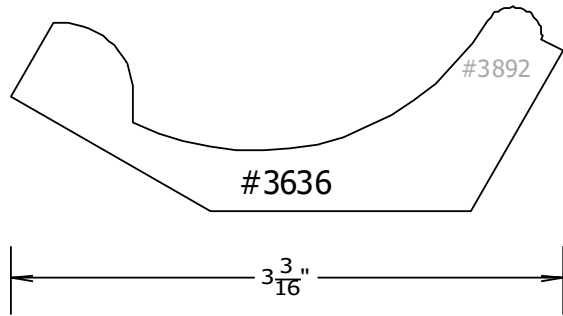
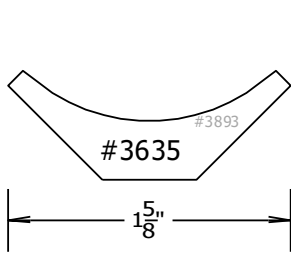
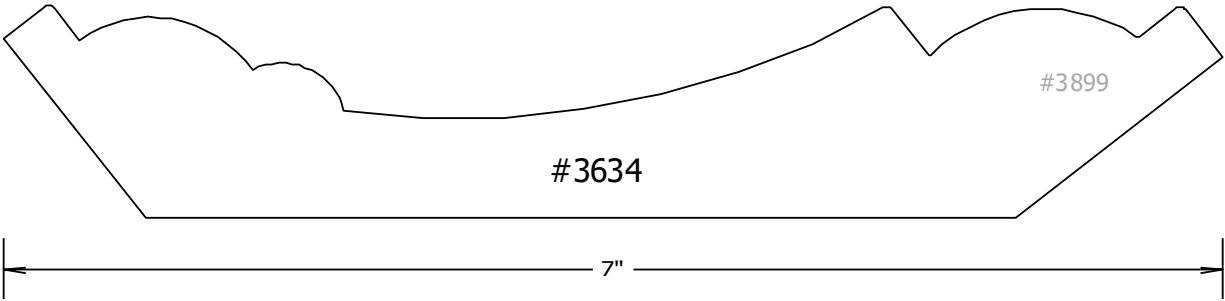

Crown Page #36

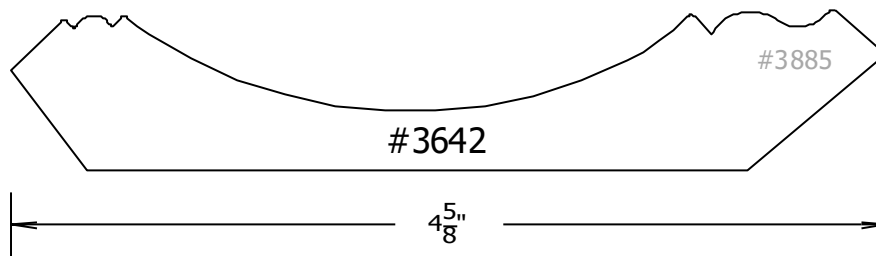
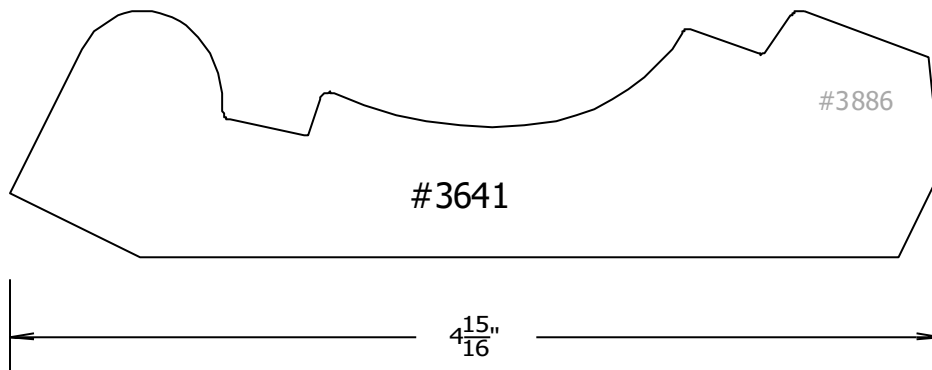
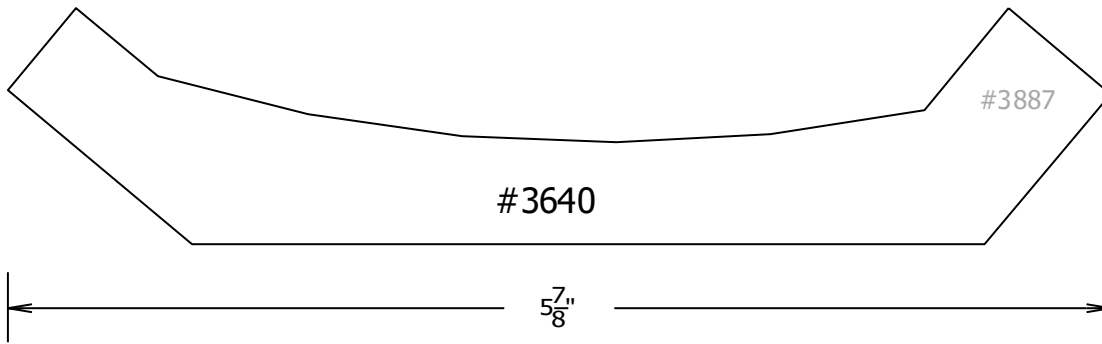
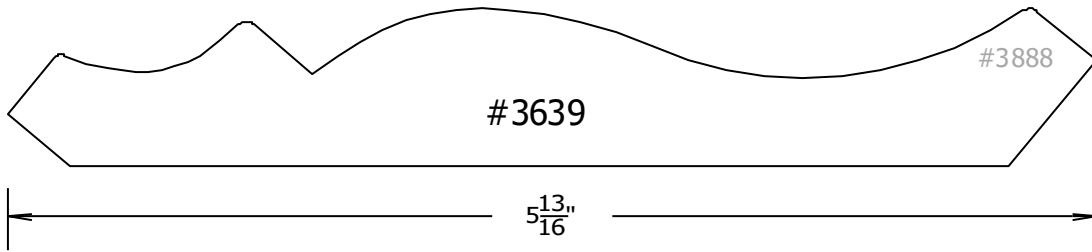



Crown Page #37

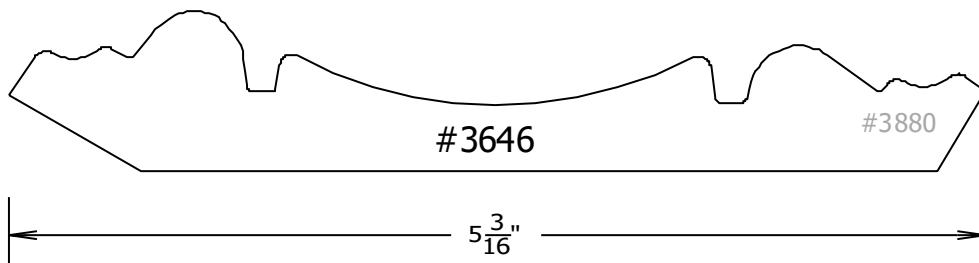
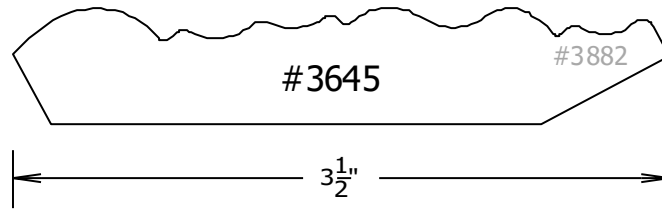
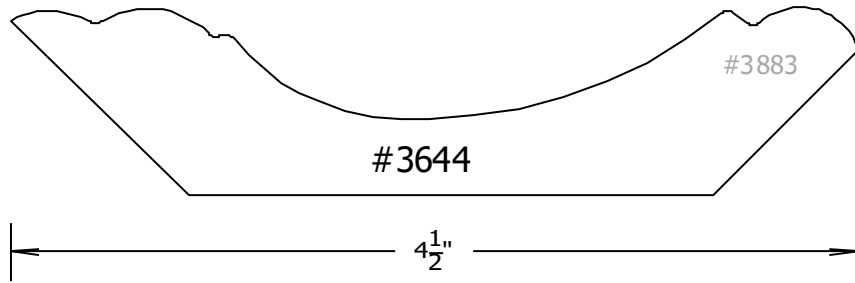
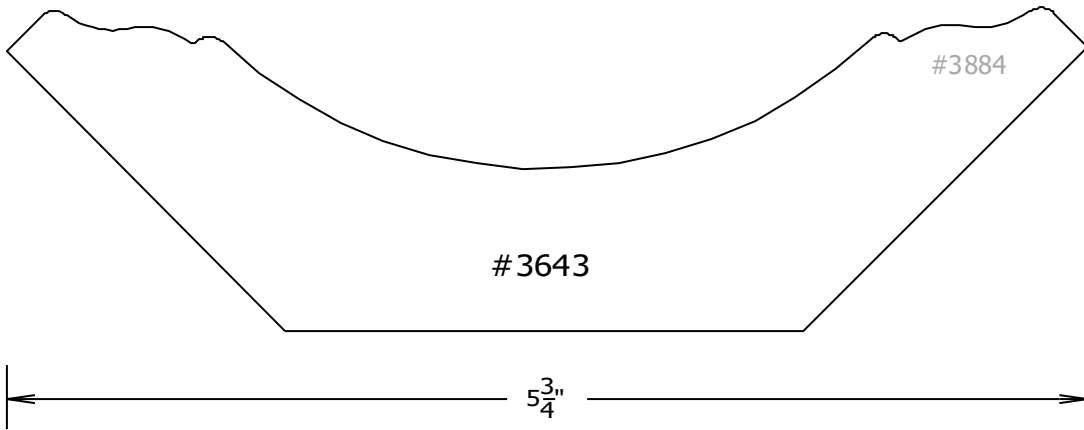

Crown Page #38

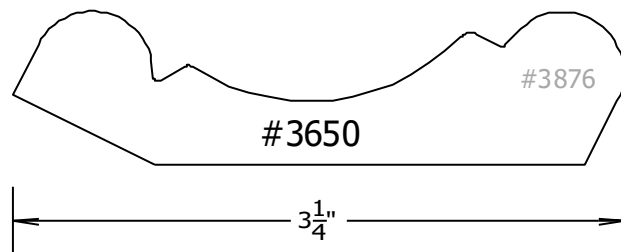
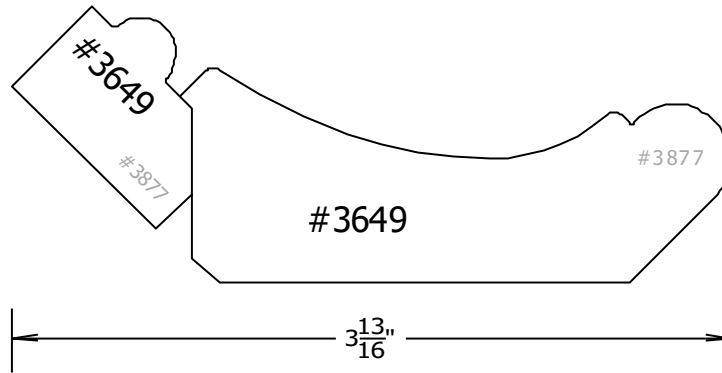
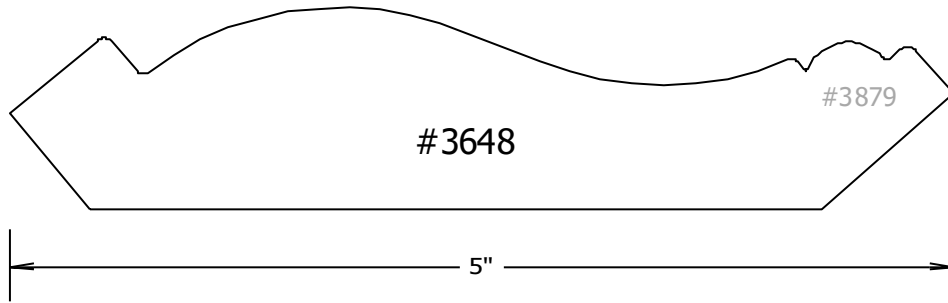
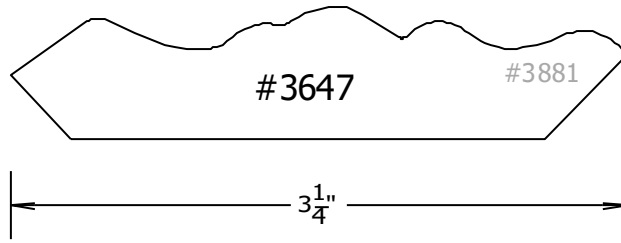

Crown Page #39

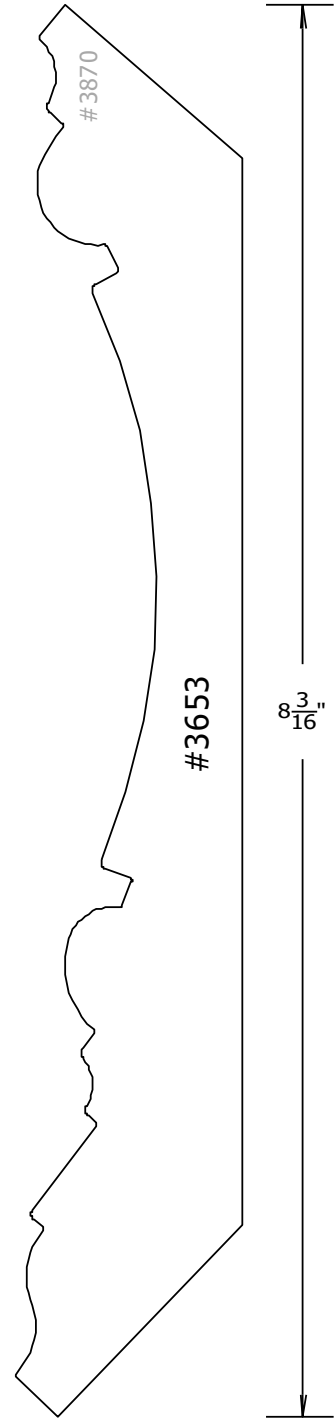
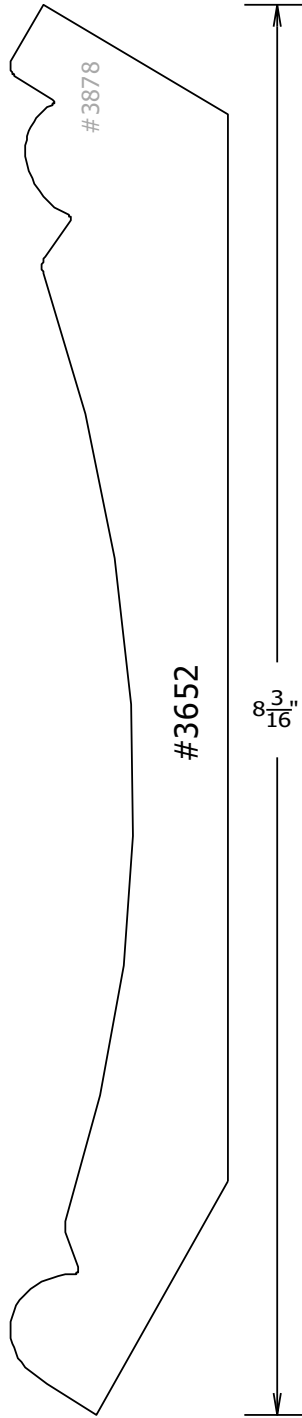
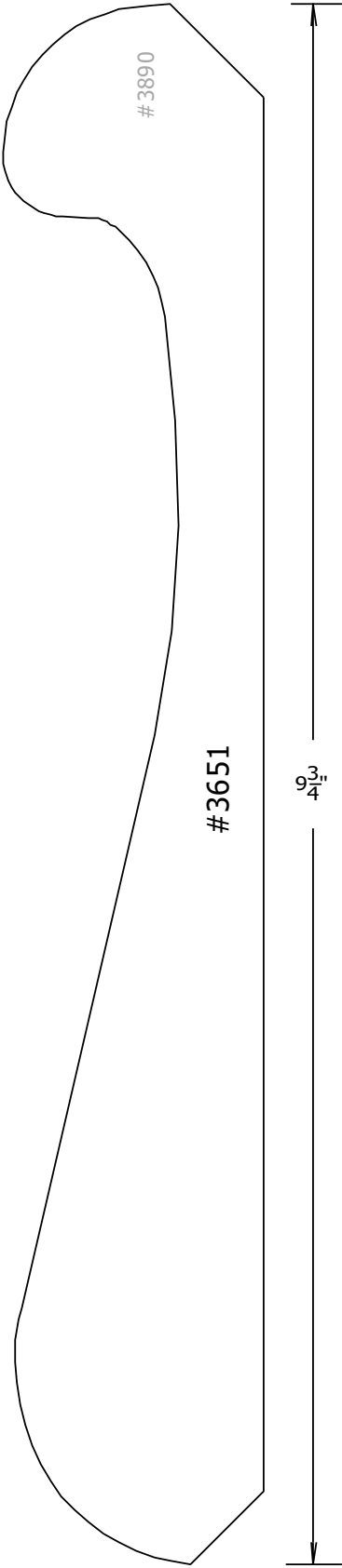

Crown Page #40

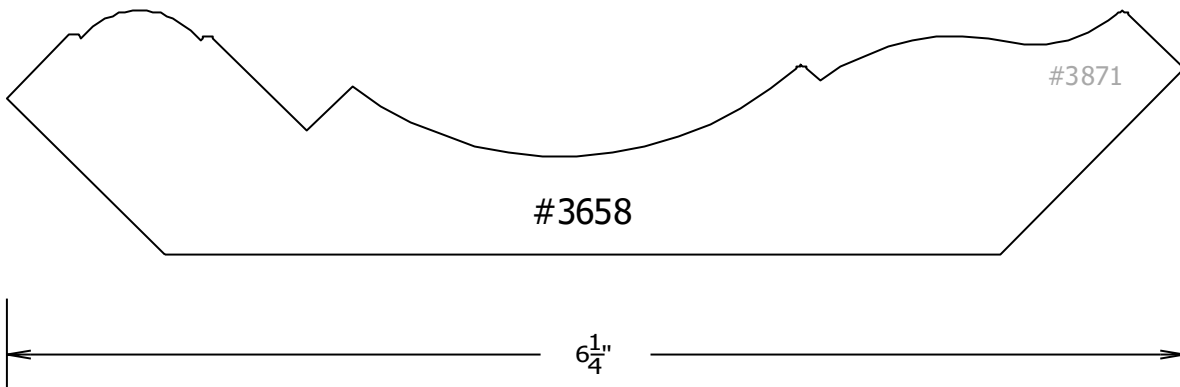
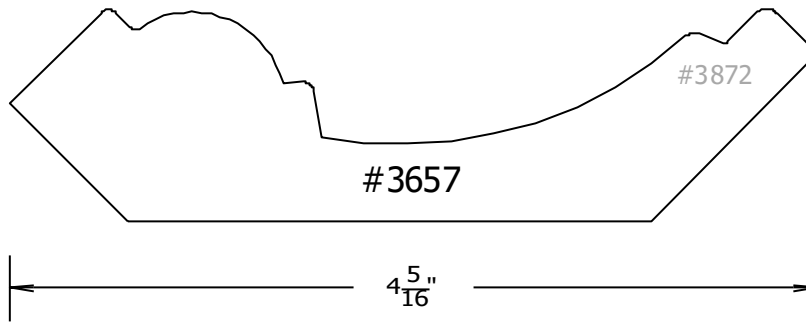
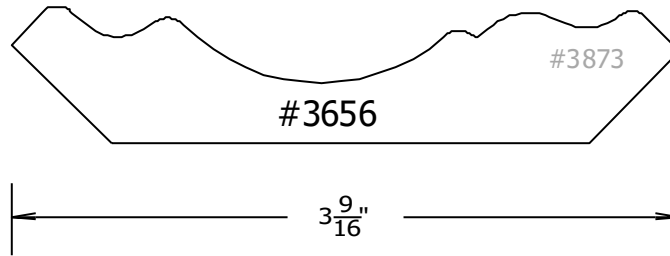
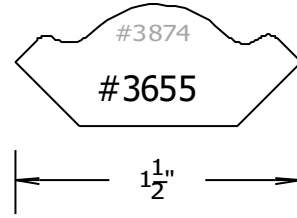
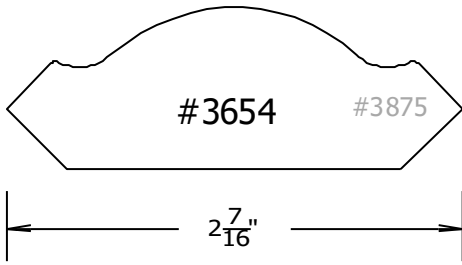

Crown Page #41

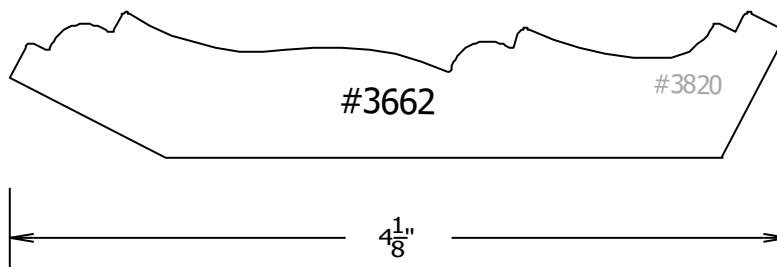
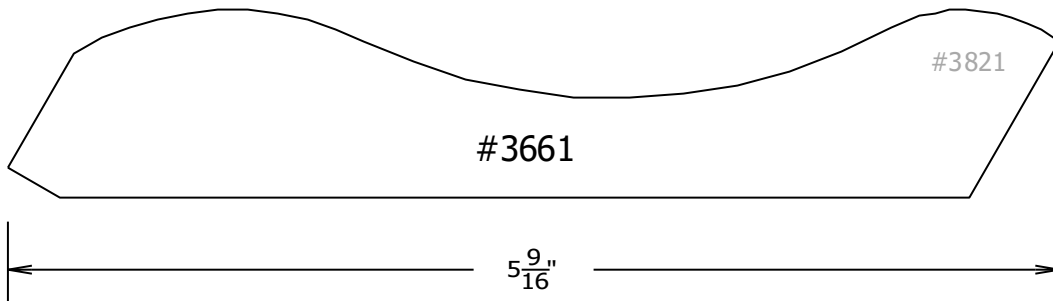
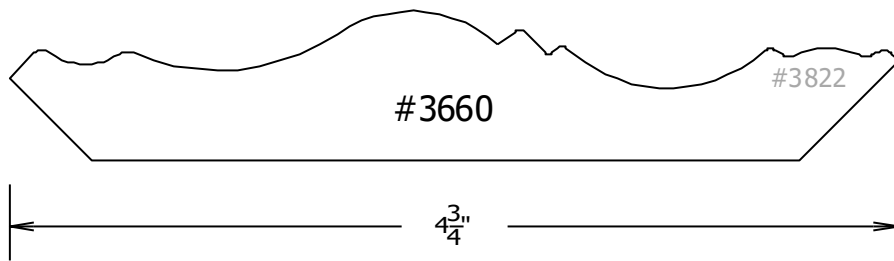
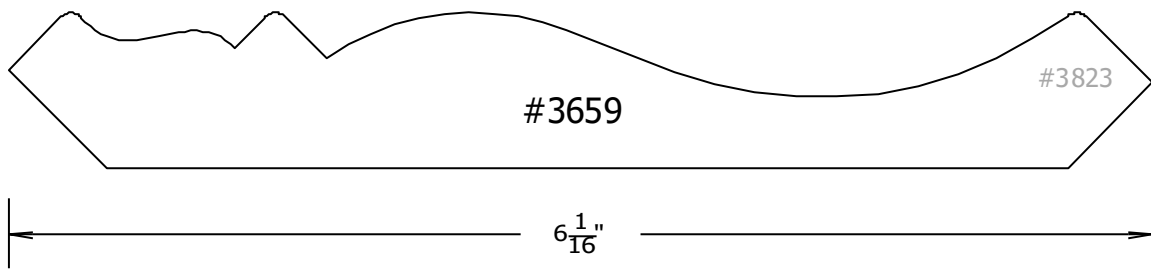

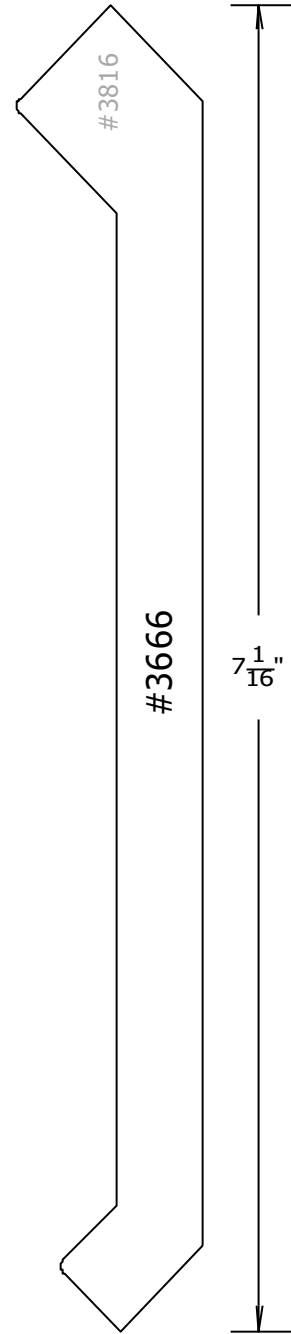
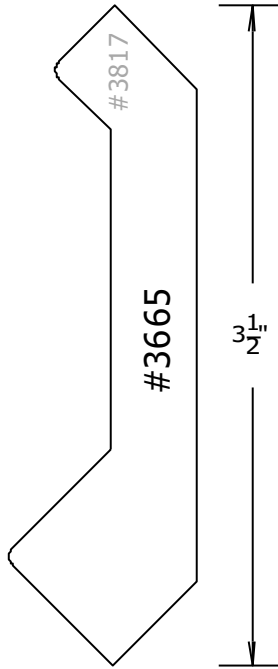
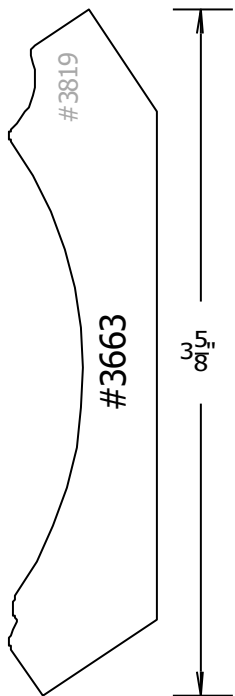
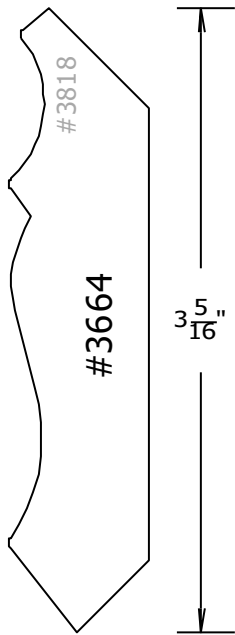

Crown Page #43

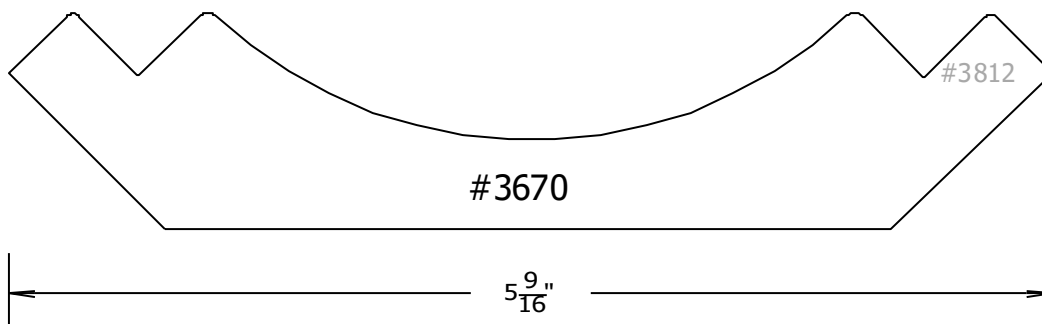
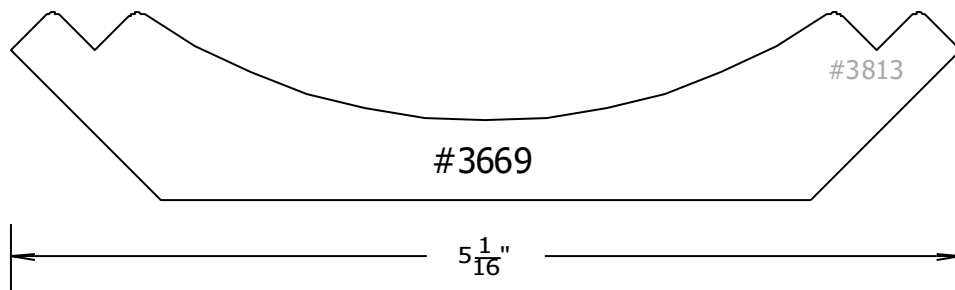
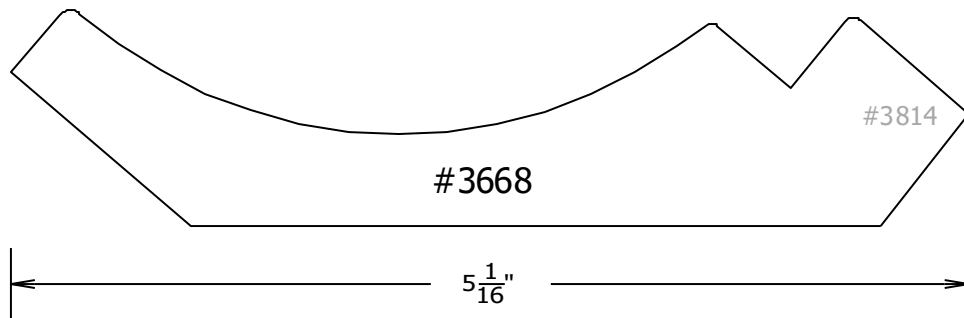
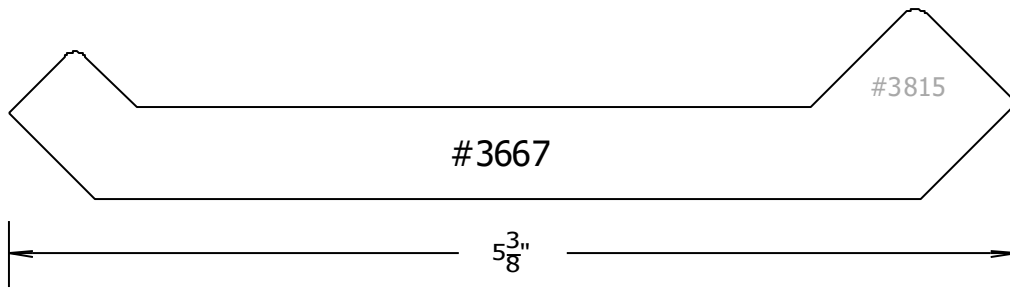

Crown Page #44

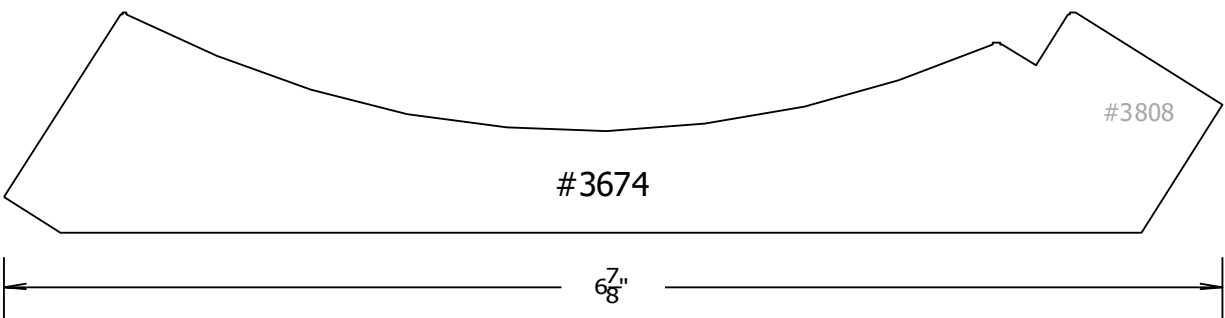
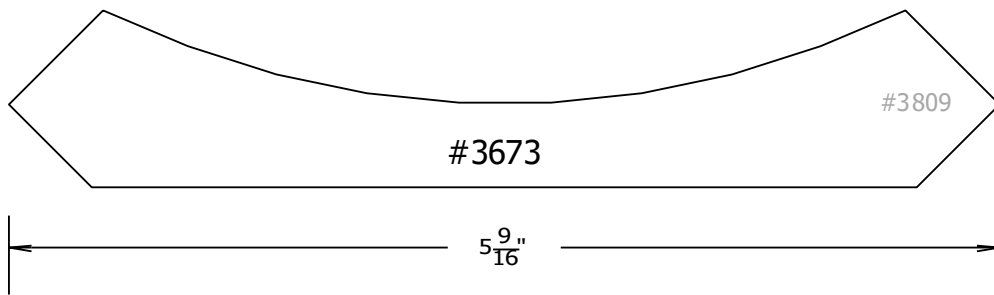
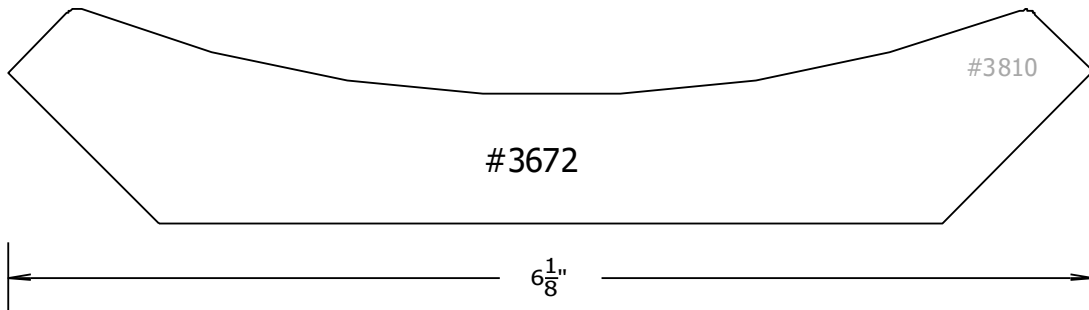
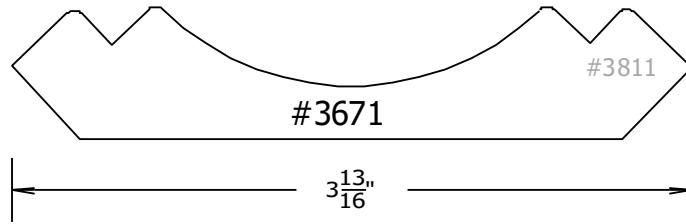



Crown Page #45

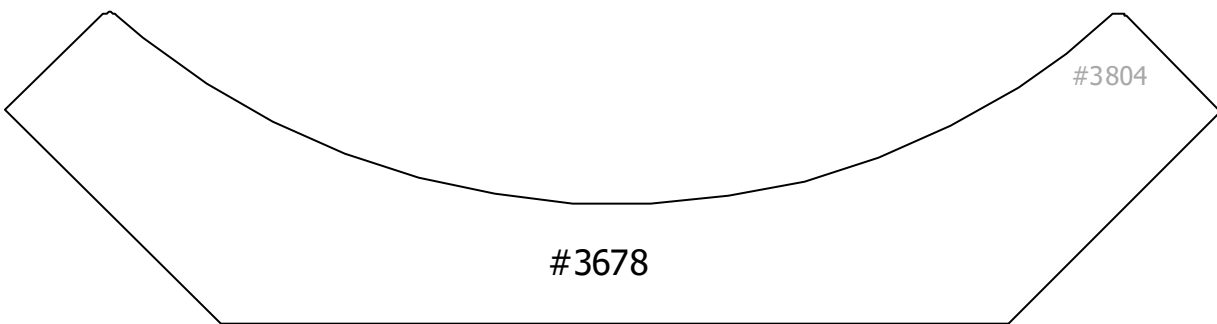
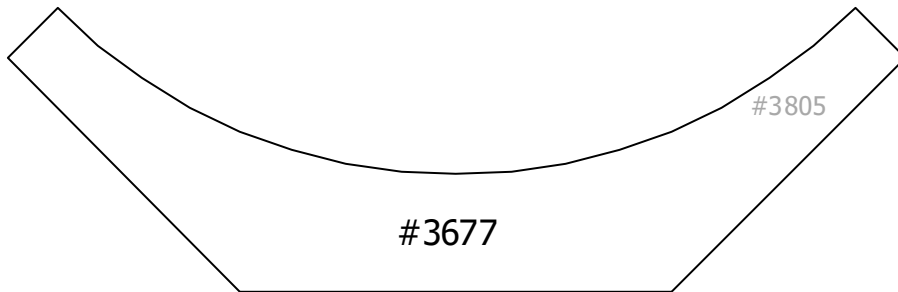
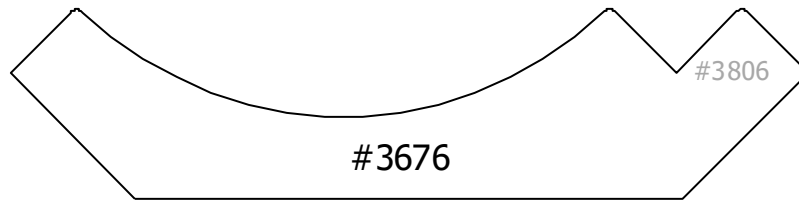
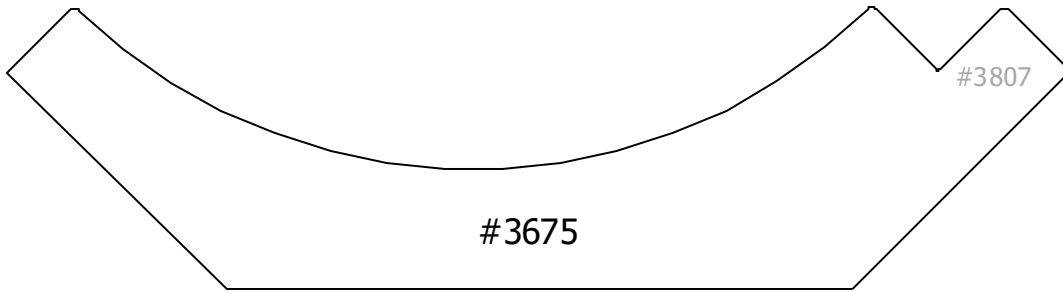

Crown Page #46

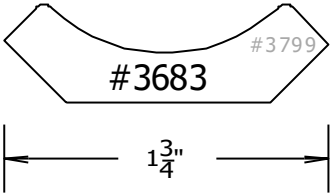
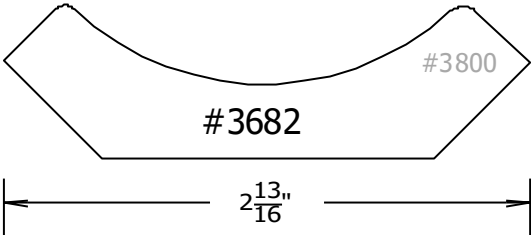
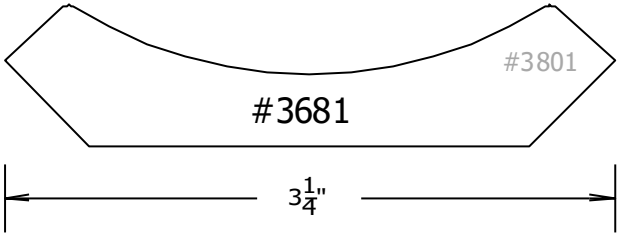
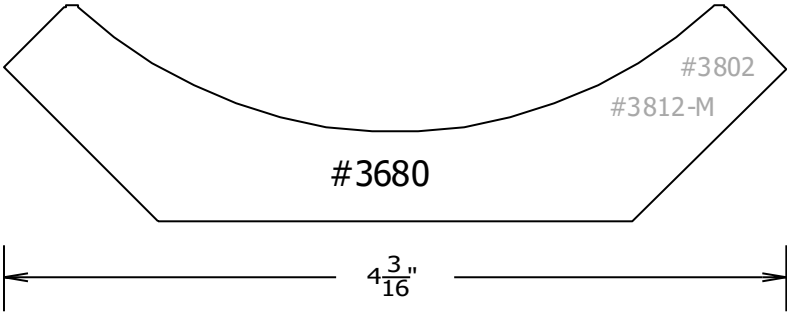
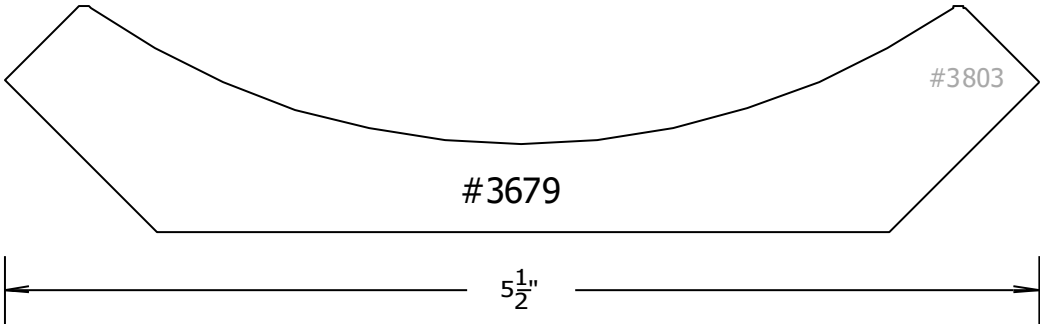

Crown Page #47

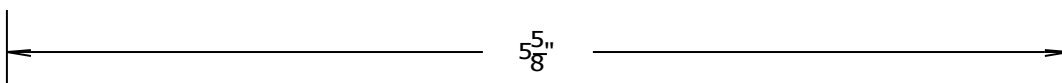
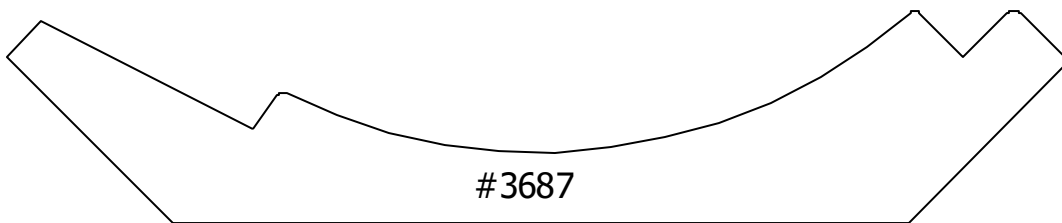
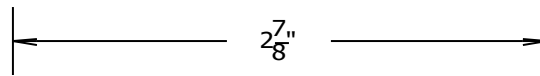
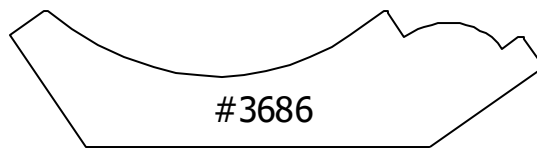
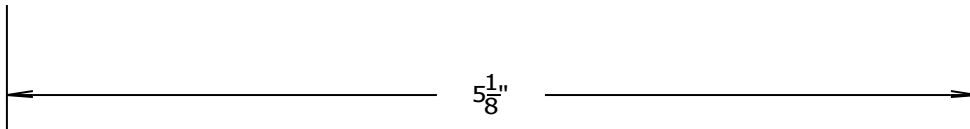
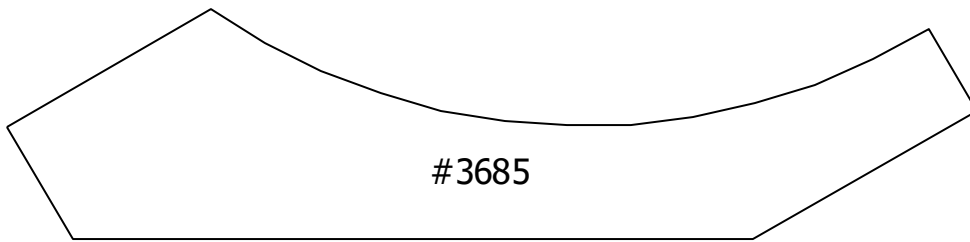
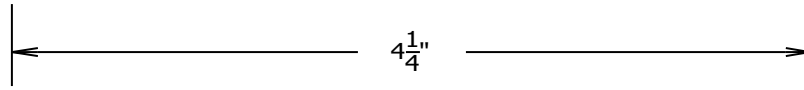
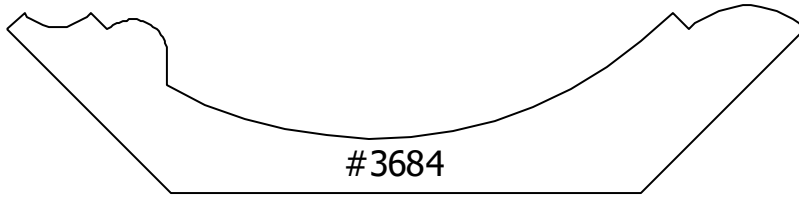

Crown Page #48

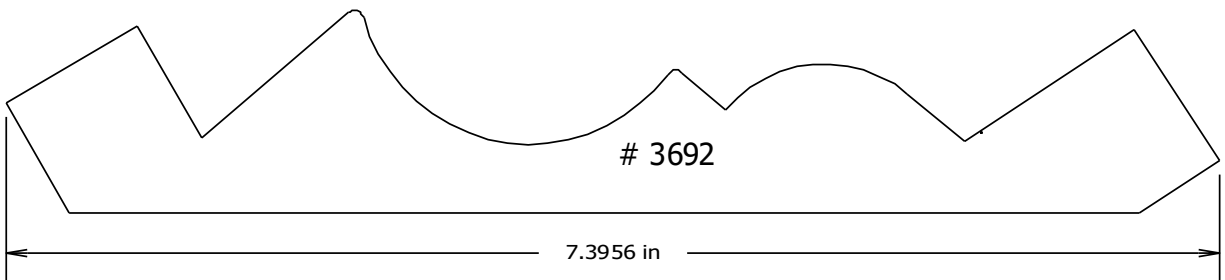
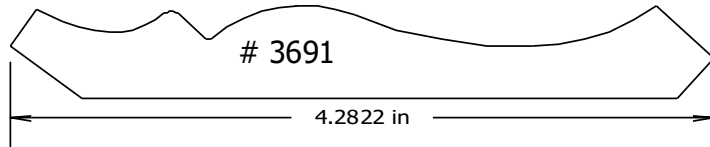
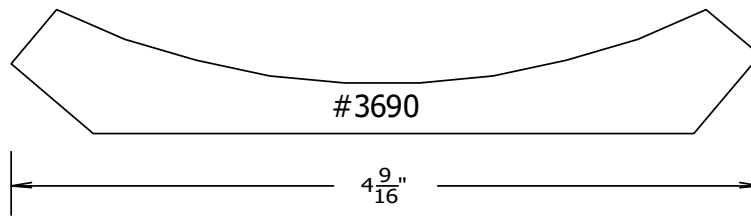
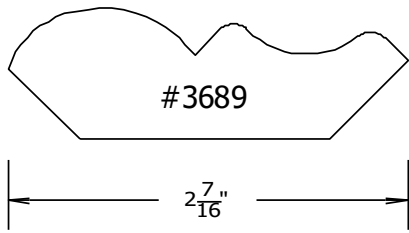
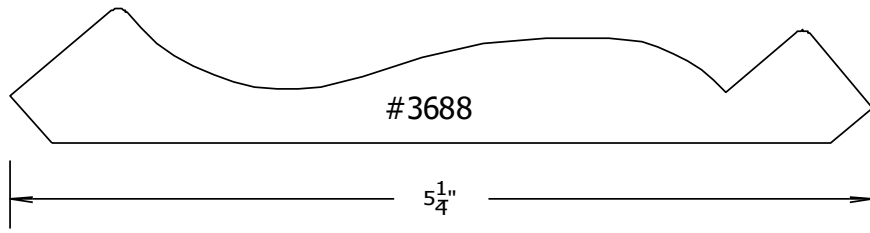

Crown Page #49

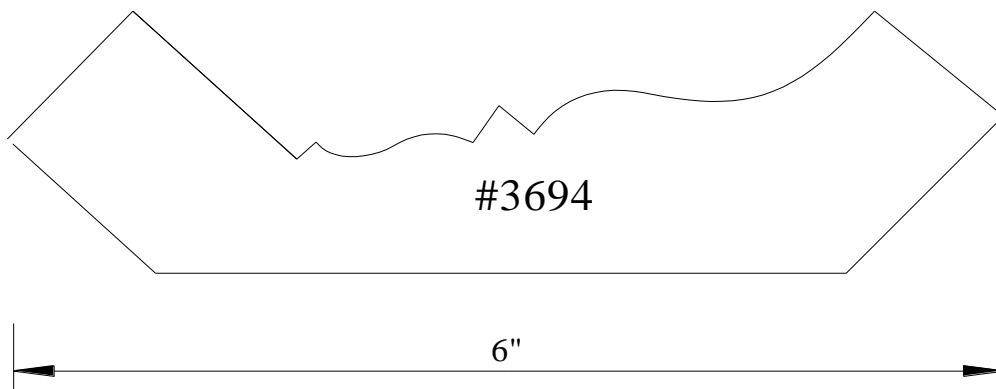
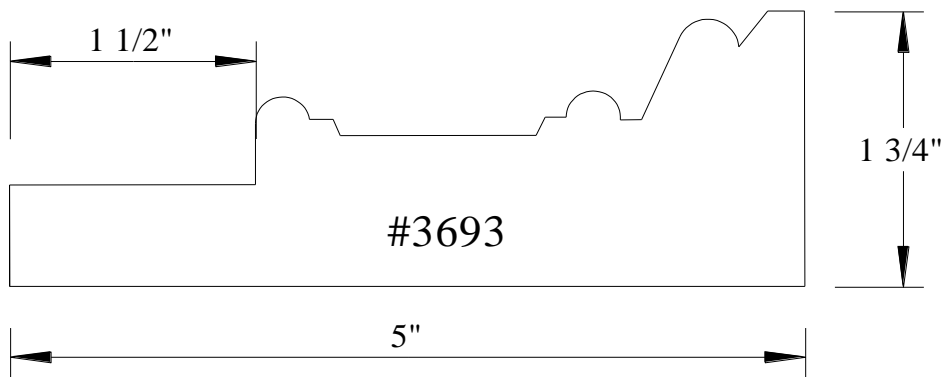
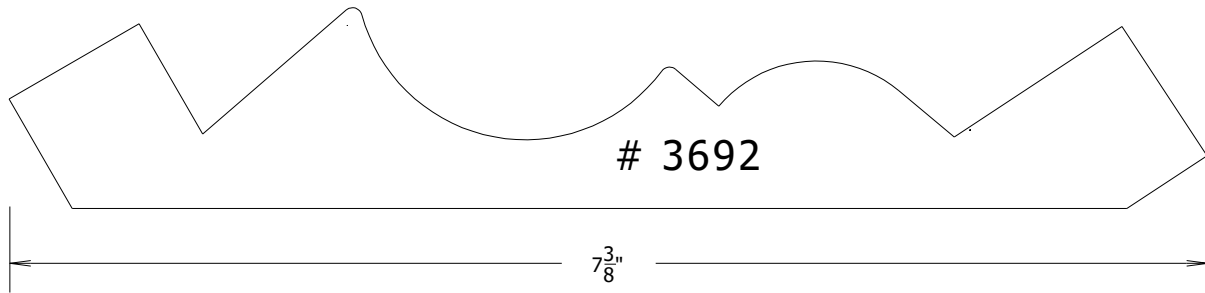
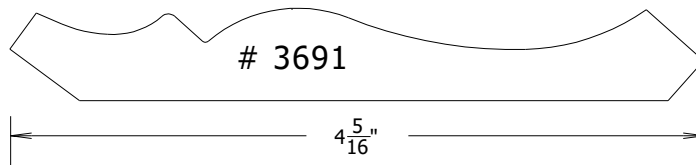

Crown Page #50

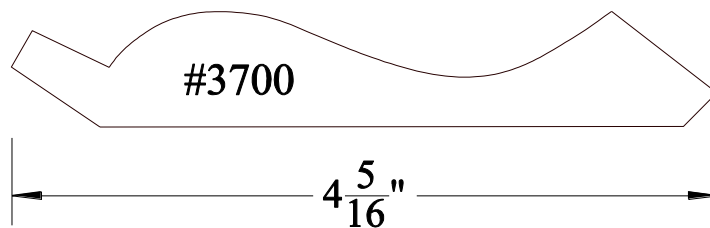
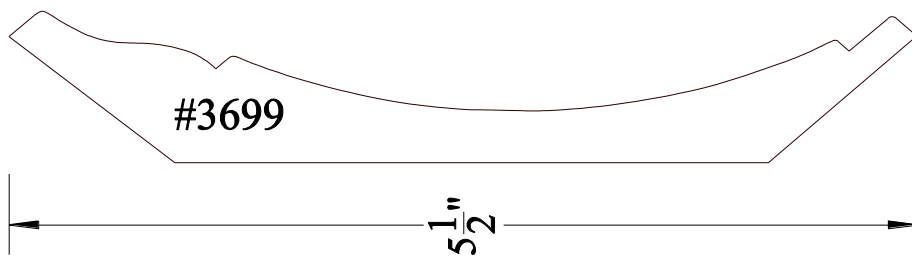
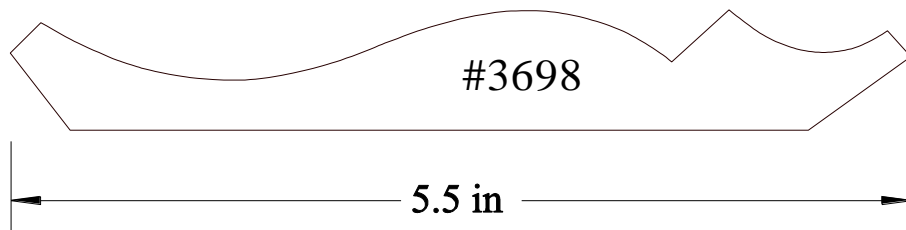
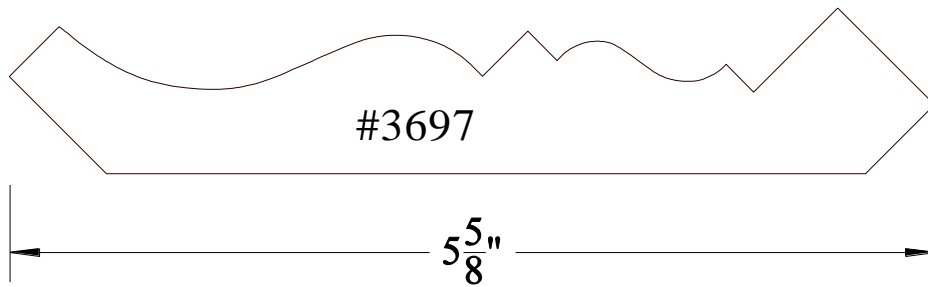
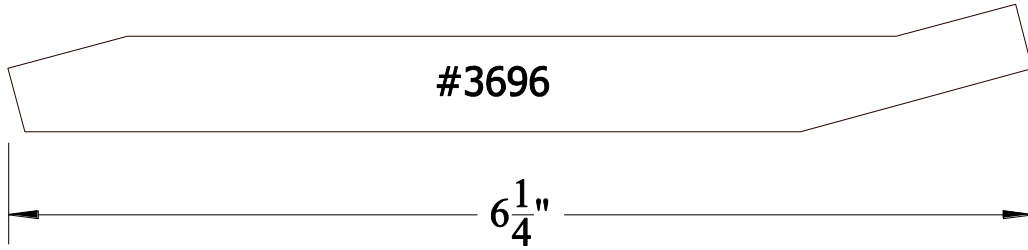

Crown Page #51

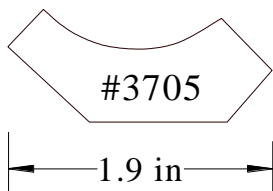
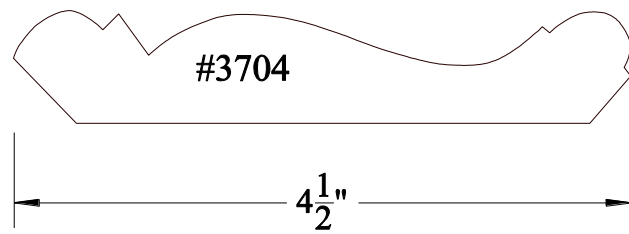
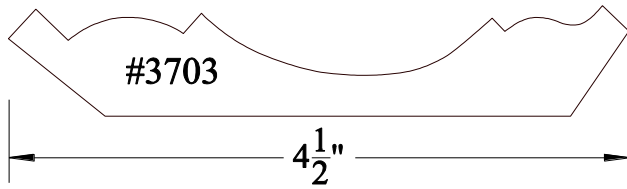
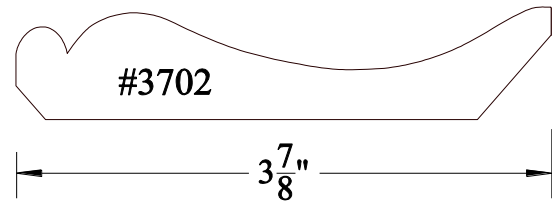
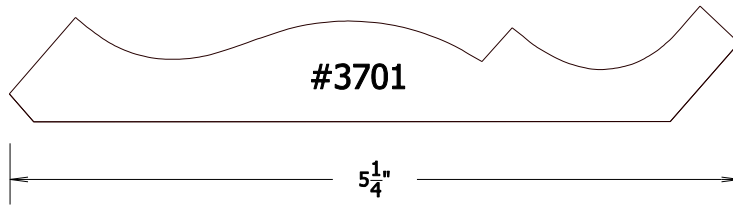

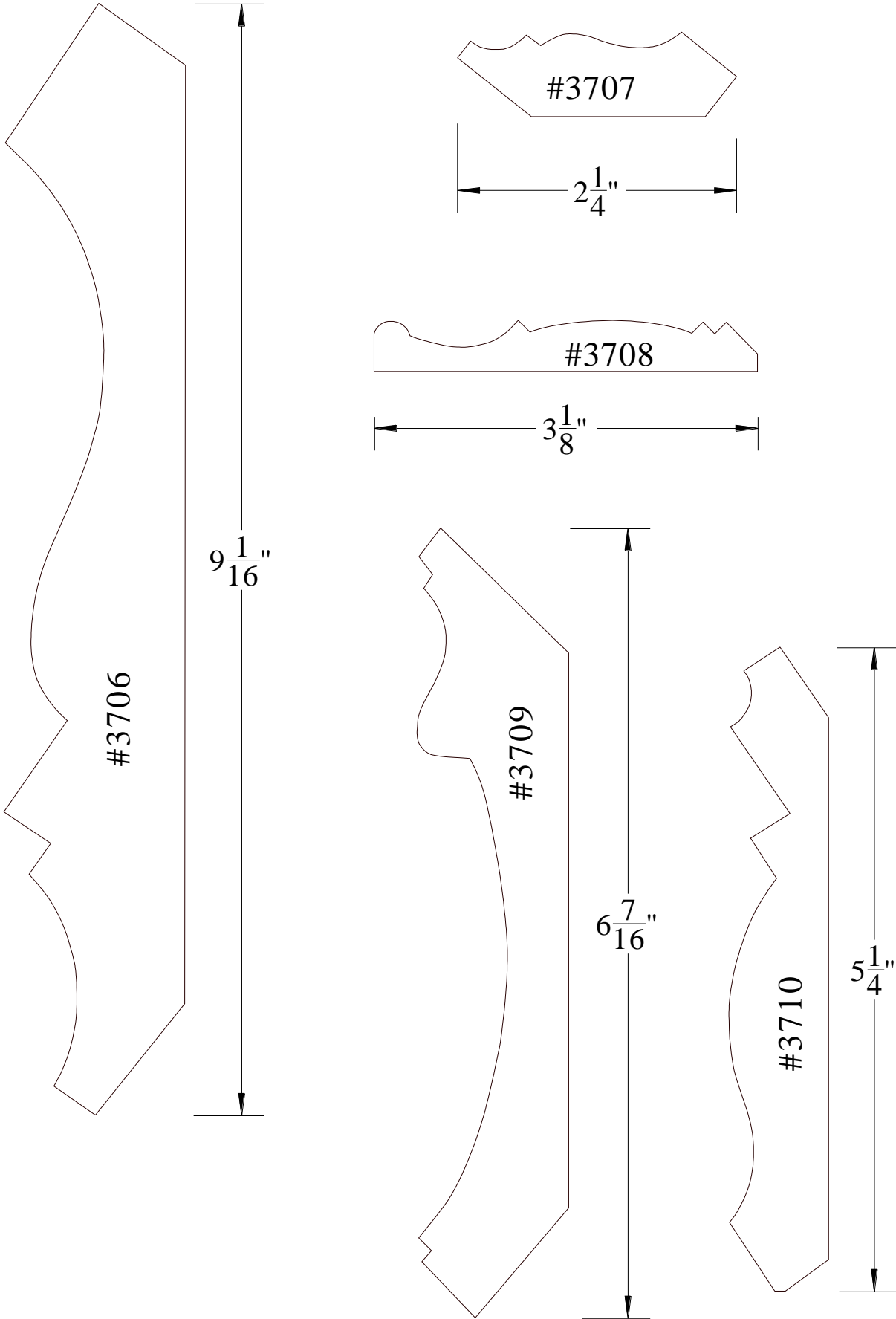



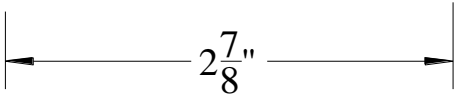
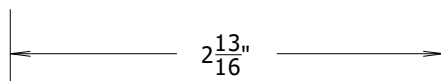
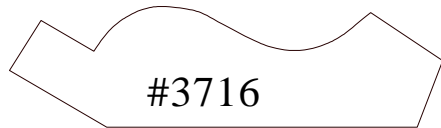
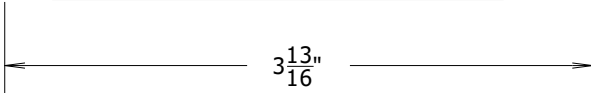
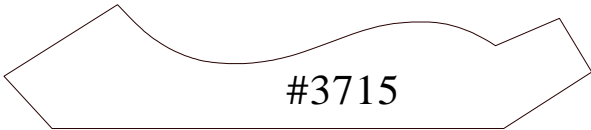
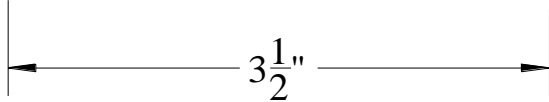
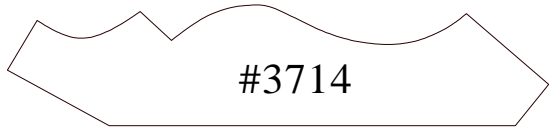
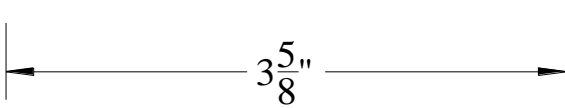
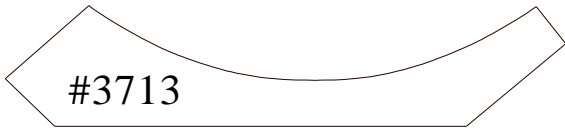
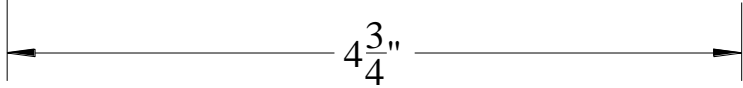
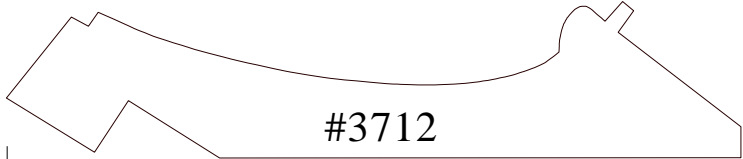
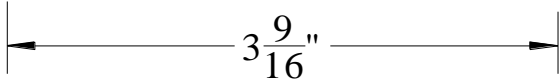
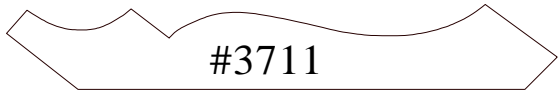

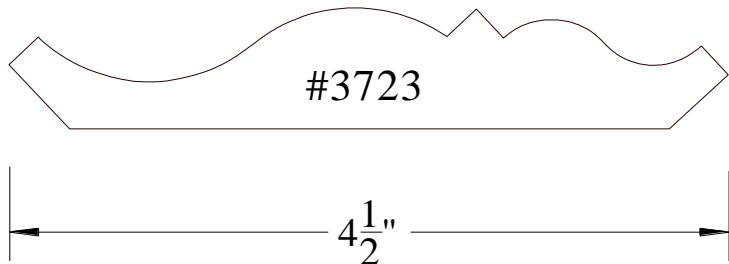
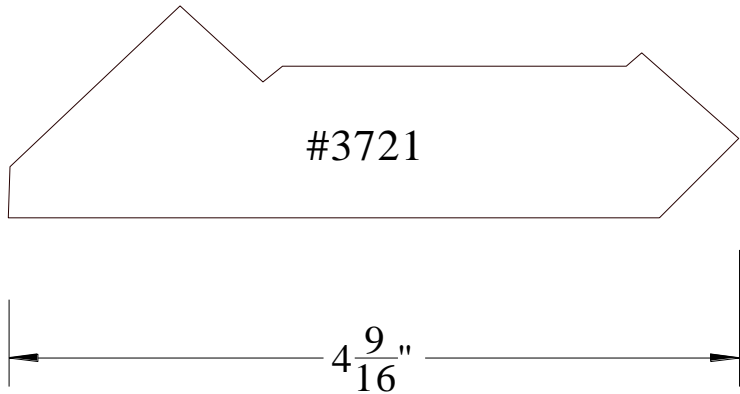
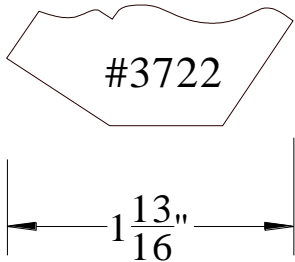
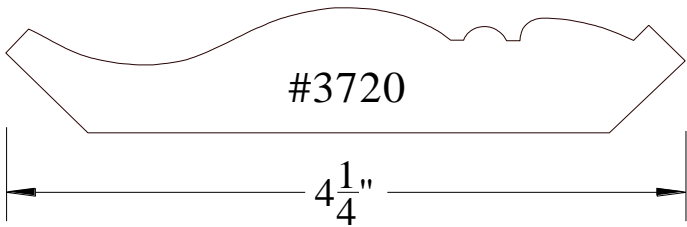
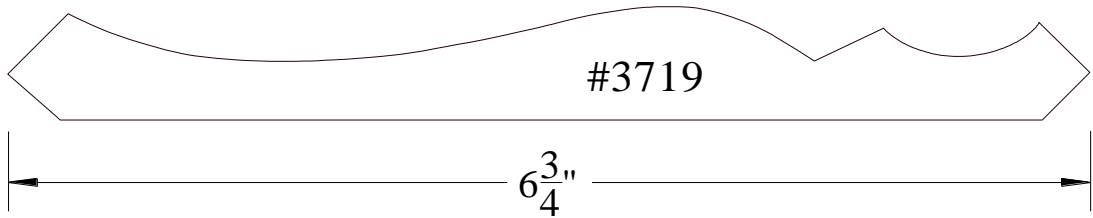
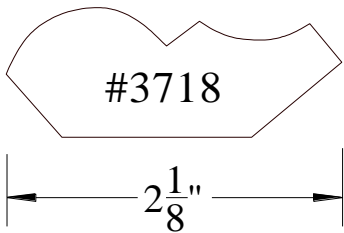

Crown Page #55

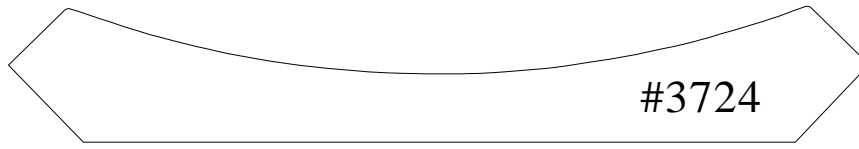

#3724

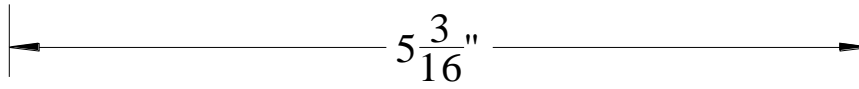

$5\frac{3}{16}$ "

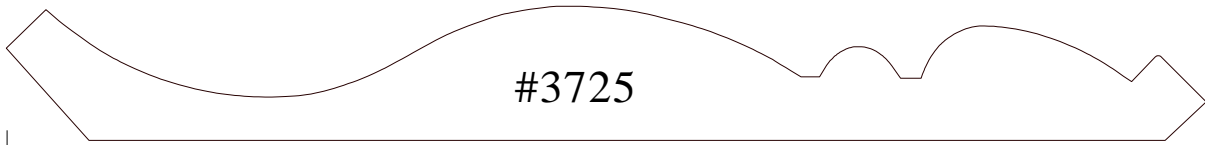

#3725

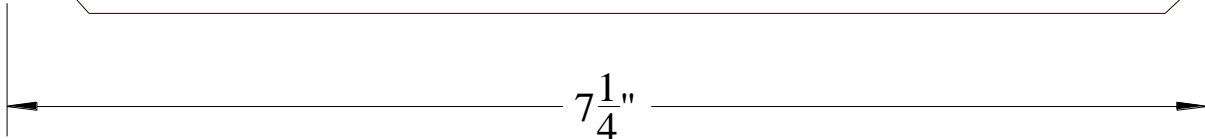

$7\frac{1}{4}$ "



#3726

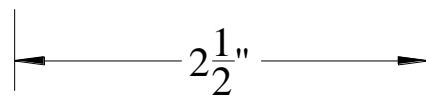

$2\frac{1}{2}$ "

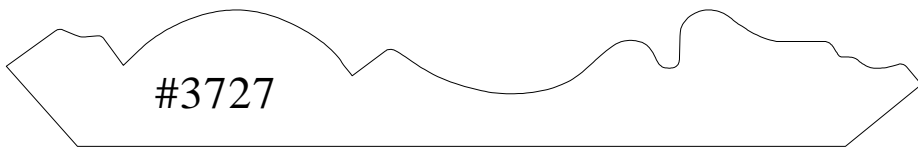

#3727

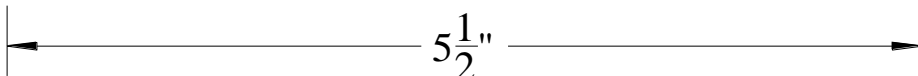

$5\frac{1}{2}$ "

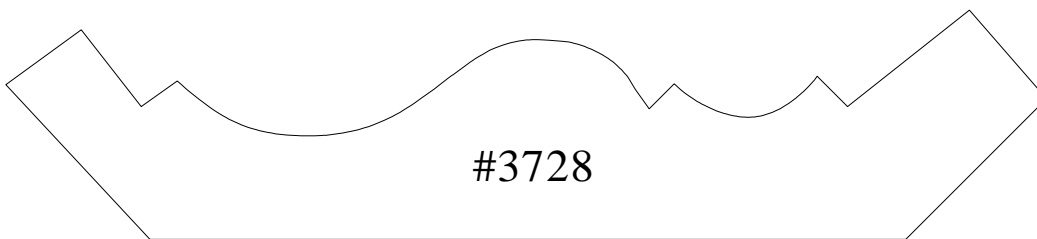

#3728

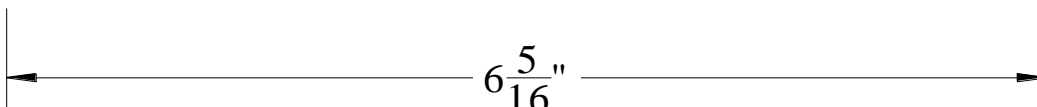

$6\frac{5}{16}$ "

# Applied Moulding Pages

There is considerable latitude when it comes to modifying these profiles.

These profiles are used as chair rails, picture frames, stiles and rails and mullion strips. Almost any conceivable use of a small to medium size moulding can be made using these profiles.

Applied Mouldings Page #1

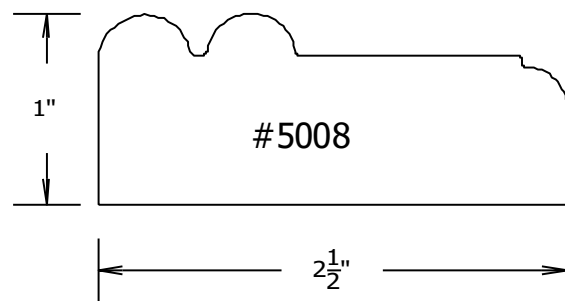
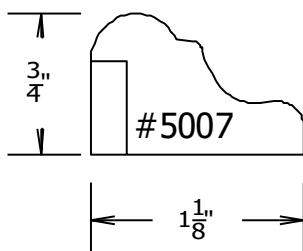
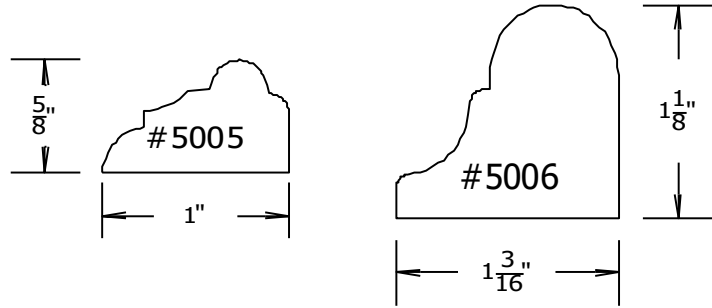
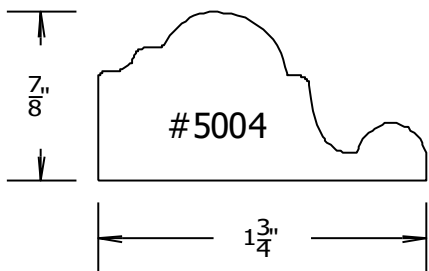
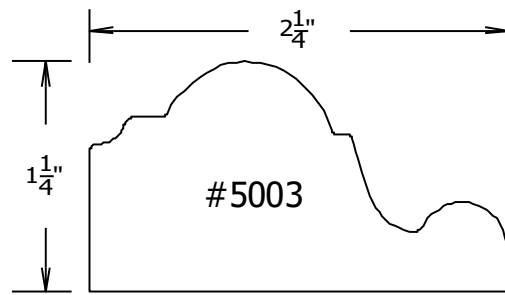
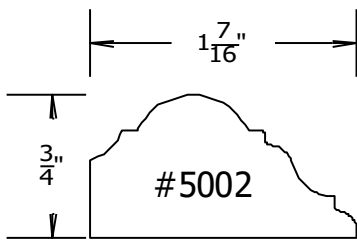
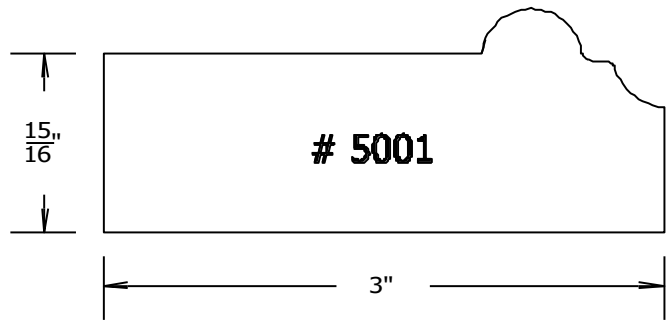
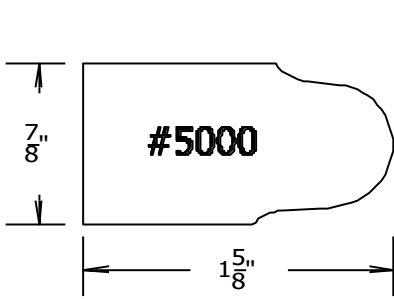

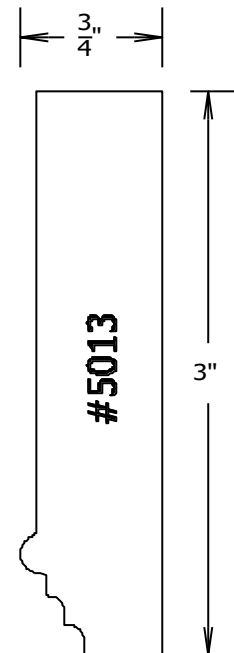
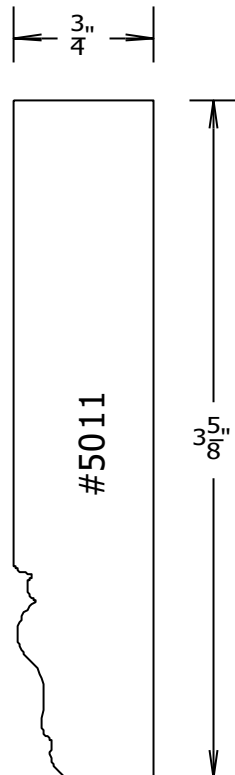
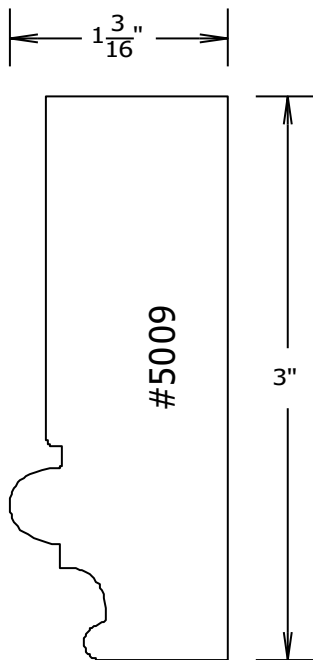
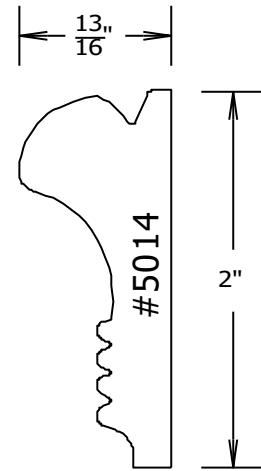
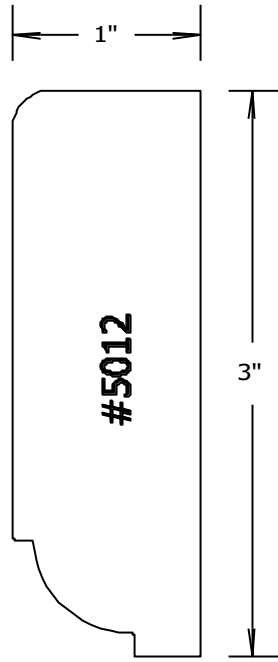
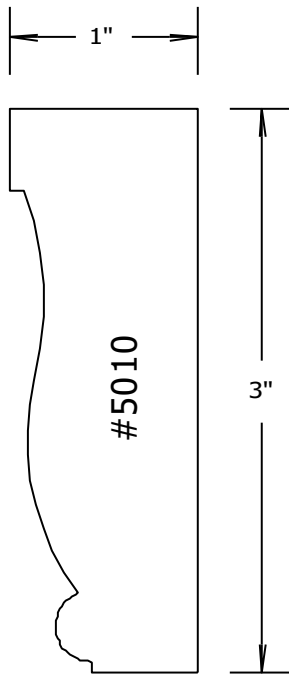

Applied Mouldings Page #3

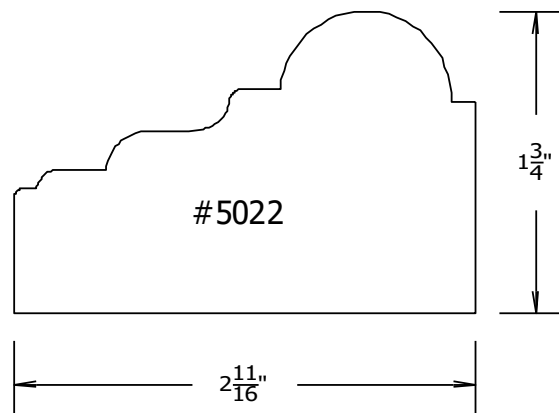
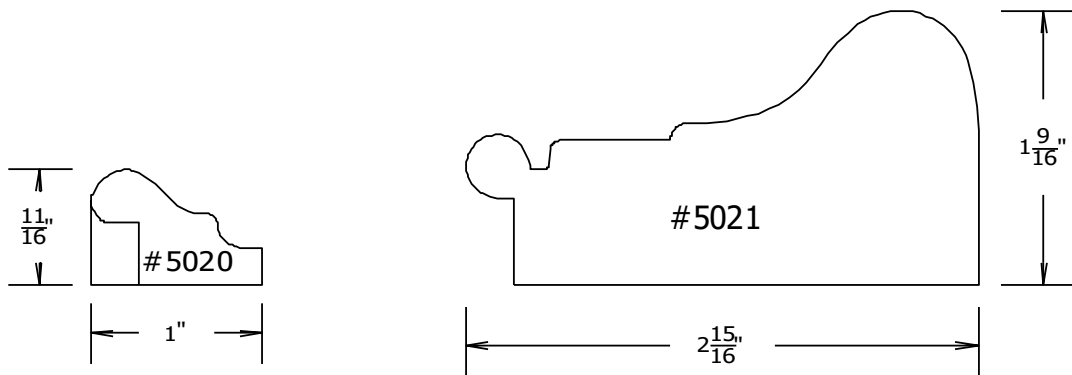
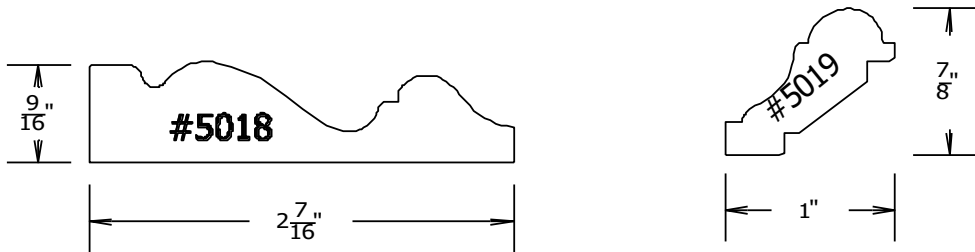
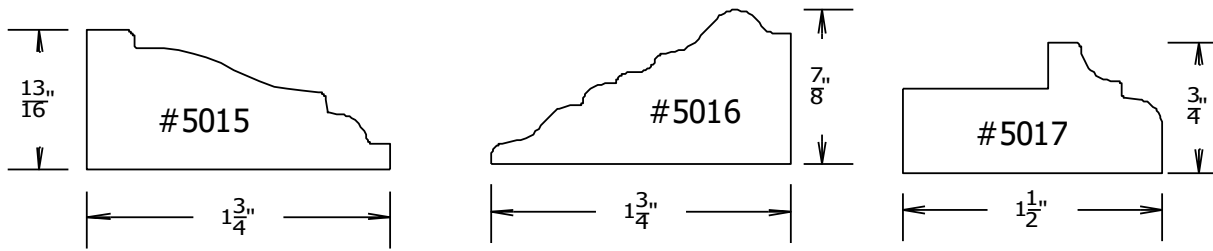

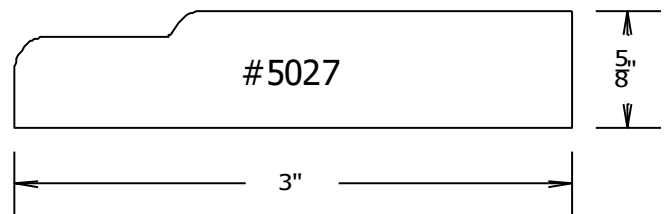
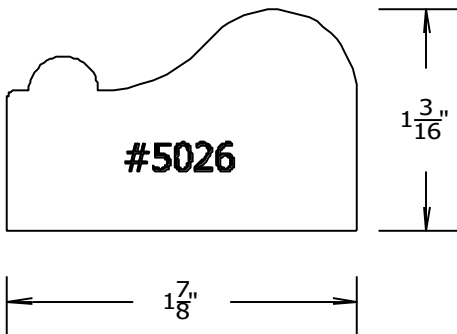
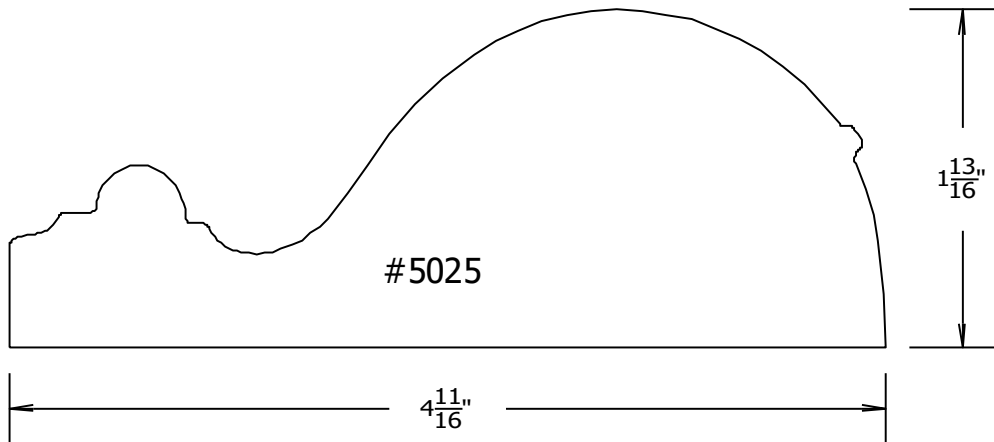
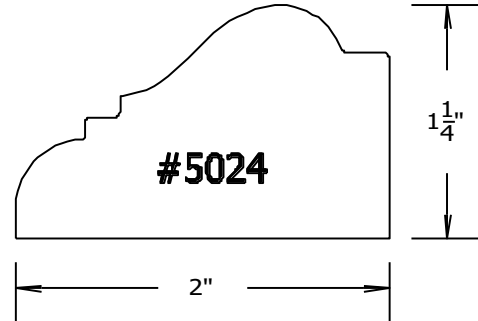
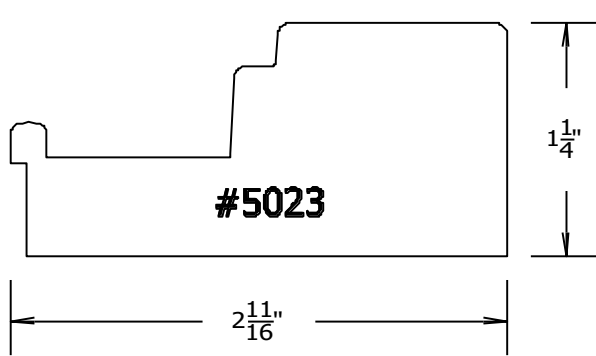



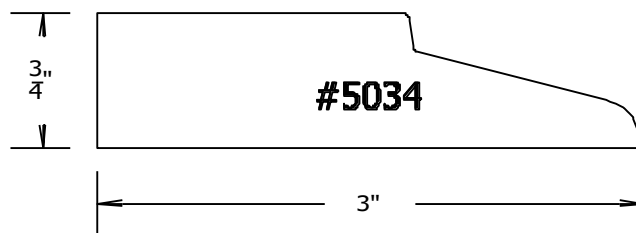
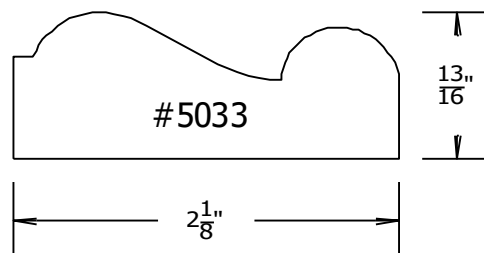
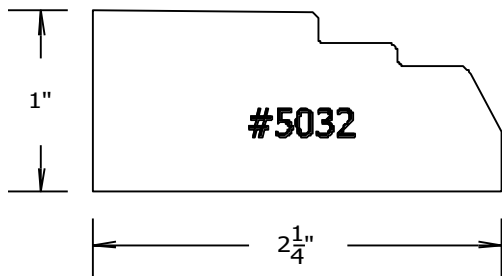
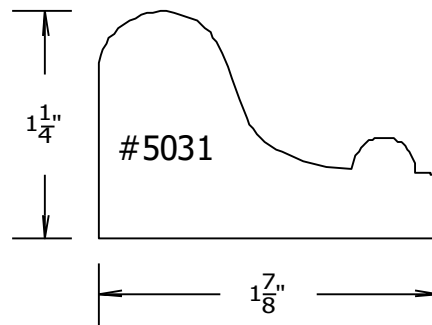
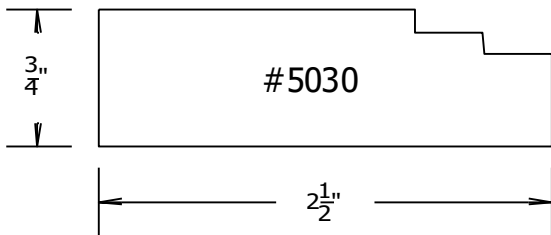
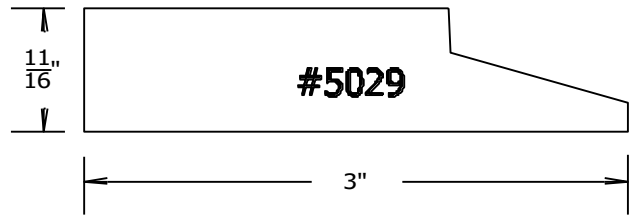
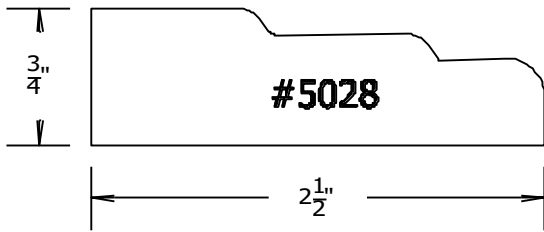

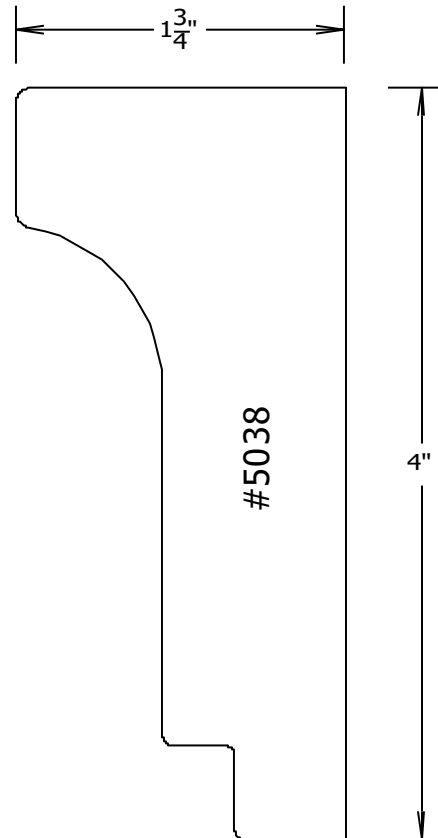
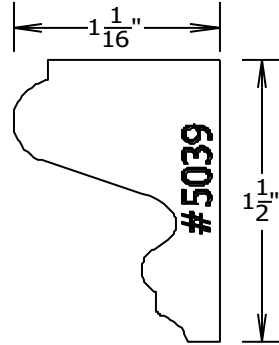
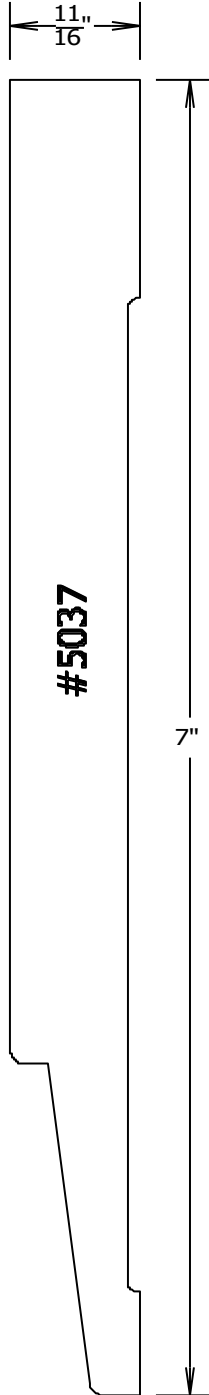
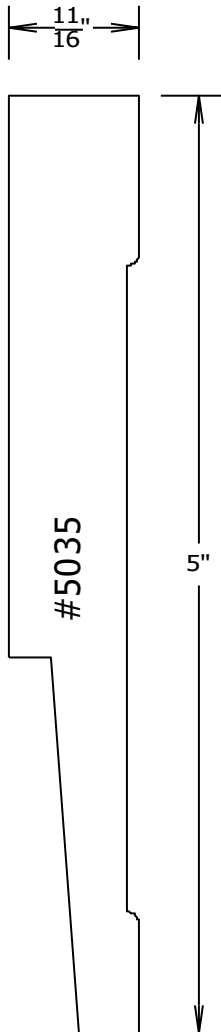
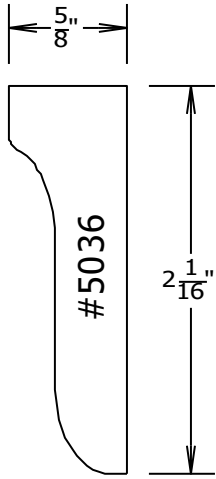

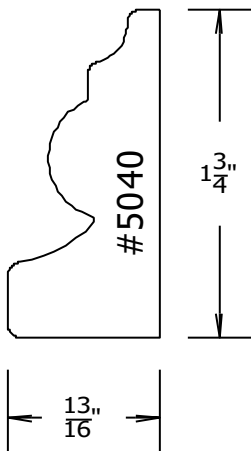
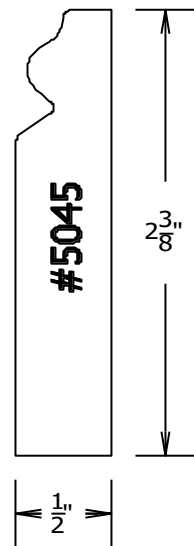
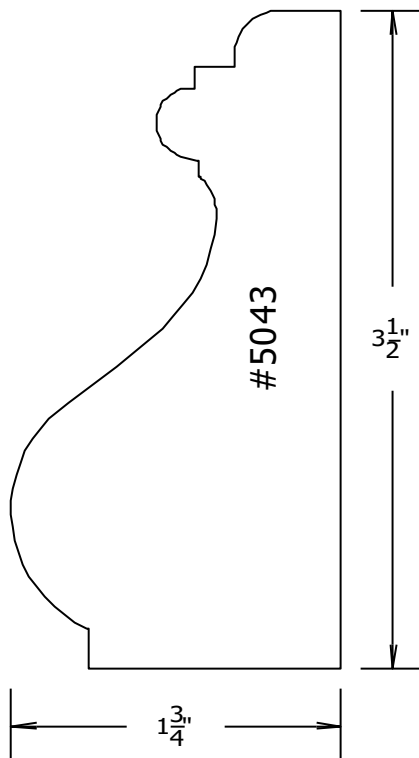
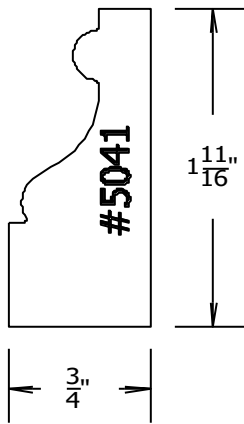
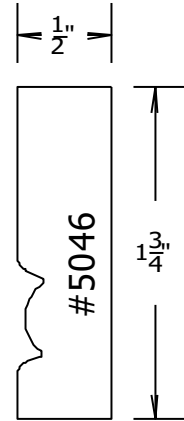
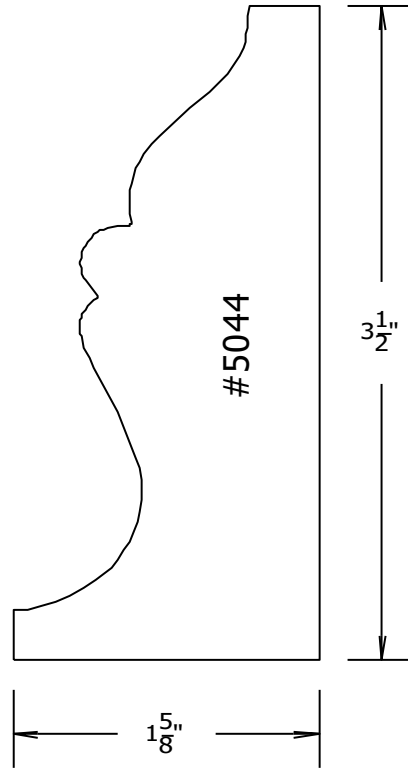
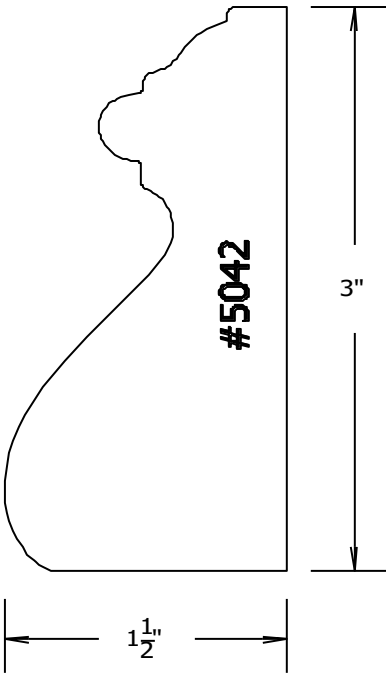

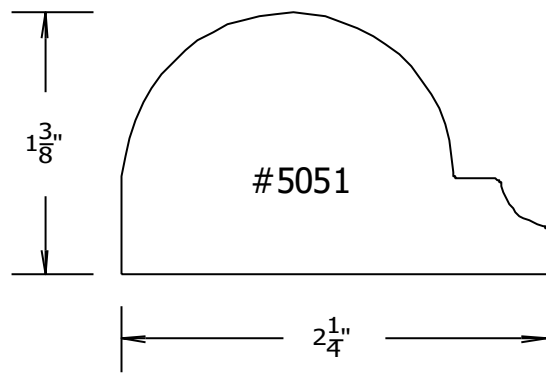
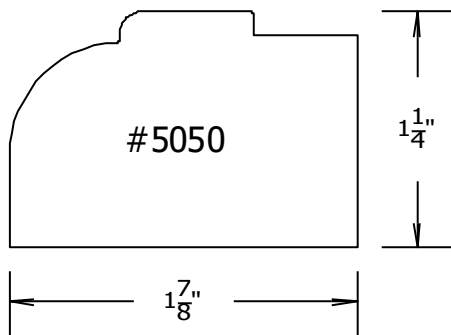
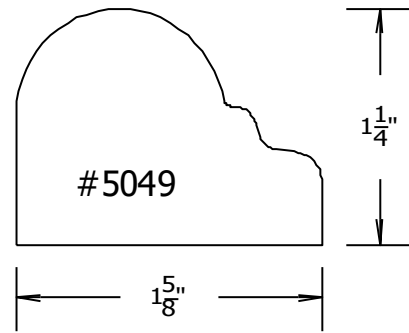
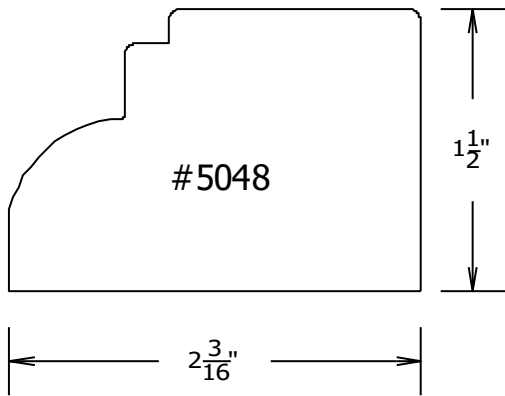
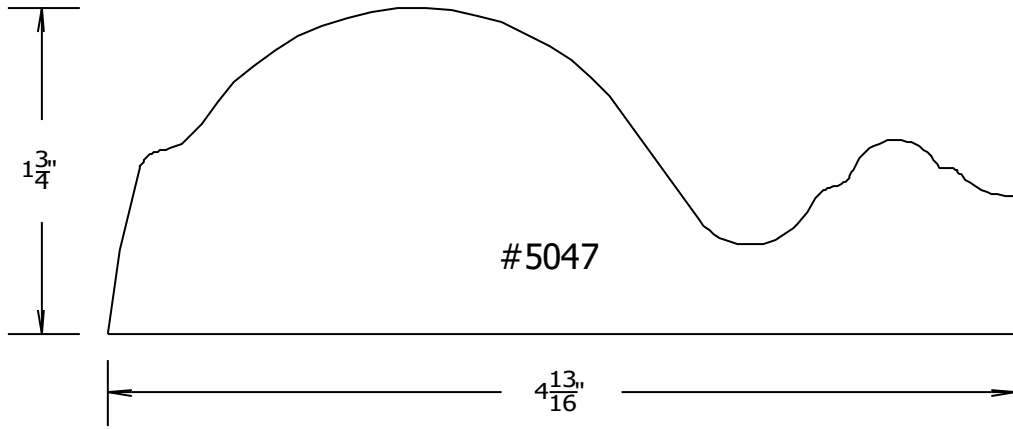

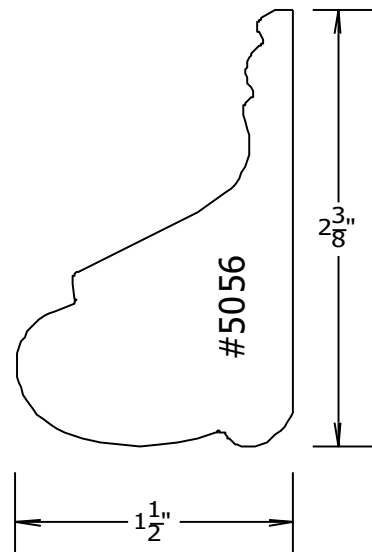
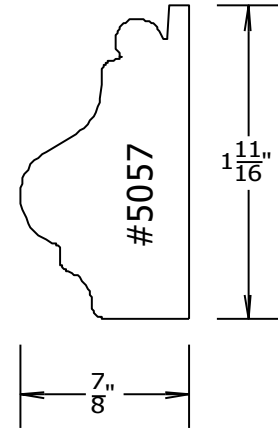
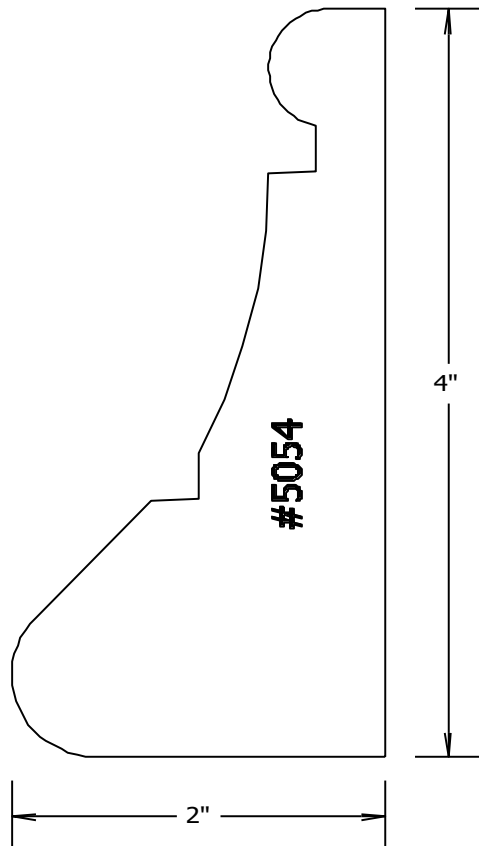
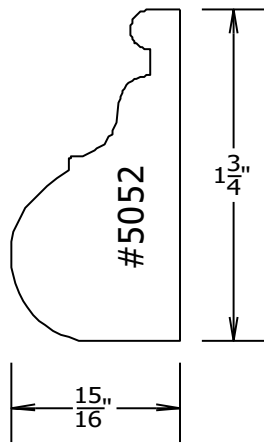
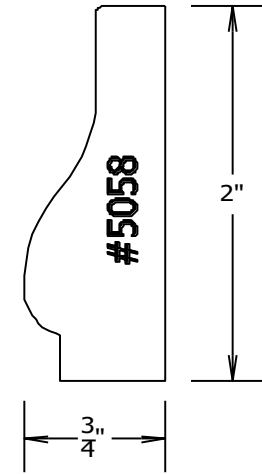
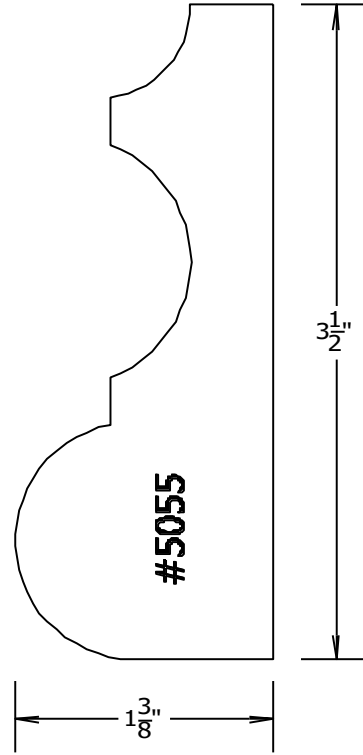
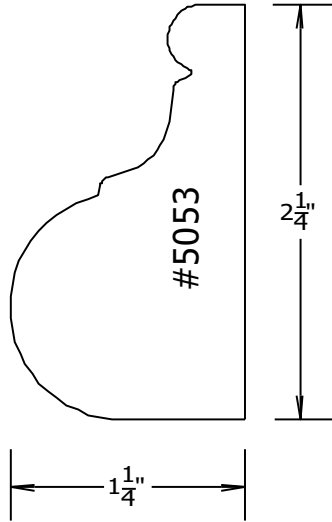

Applied Mouldings Page #10

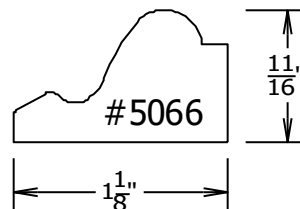
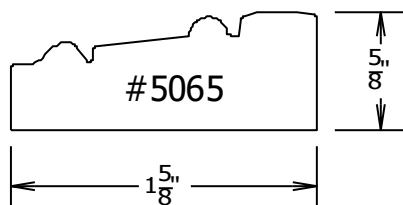
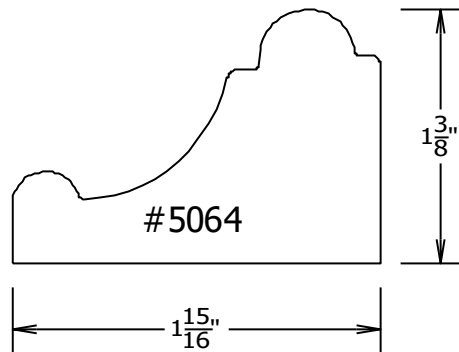
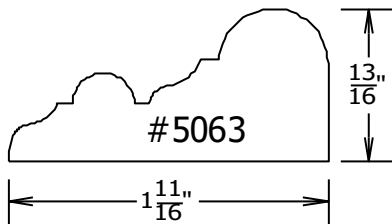
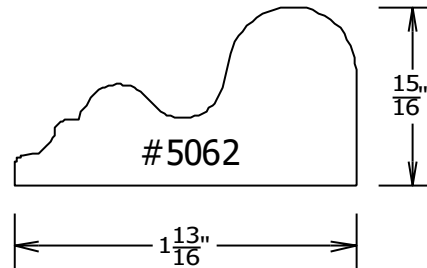
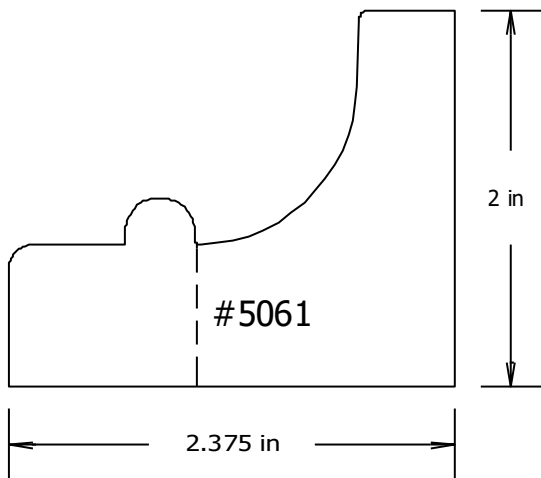
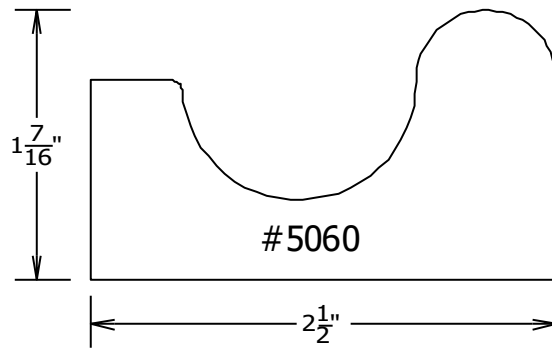
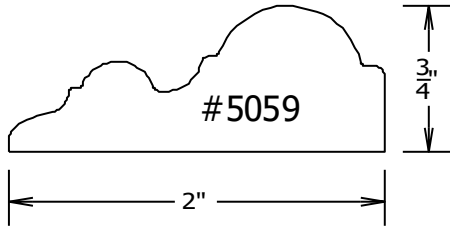

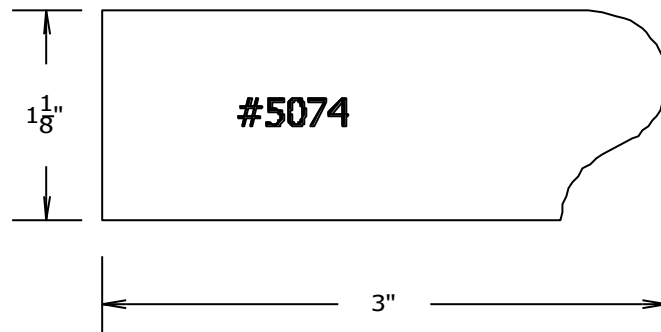
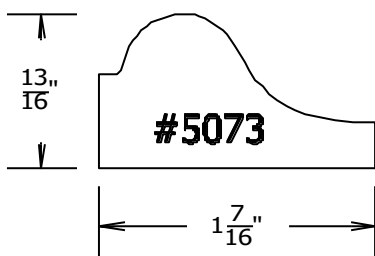
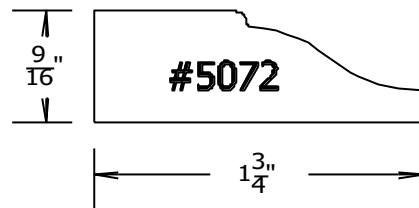
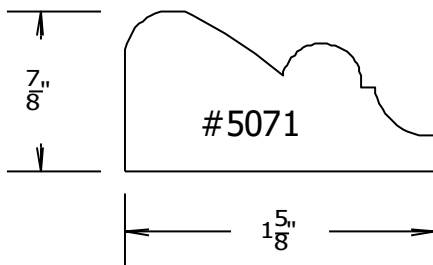
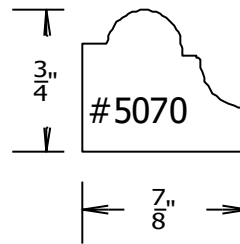
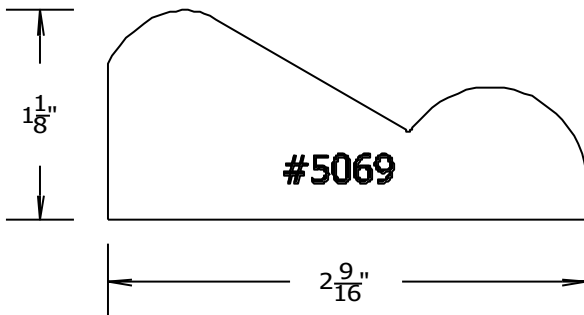
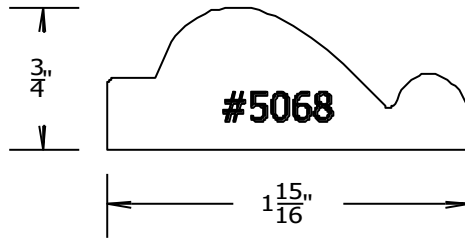
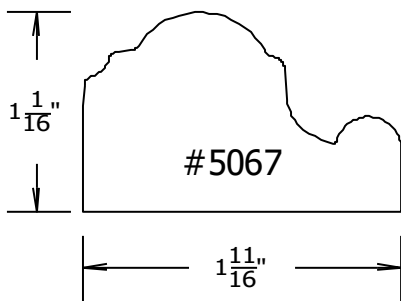

Applied Mouldings Page #12

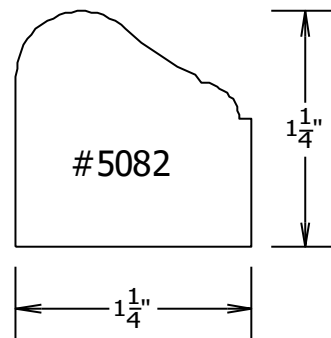
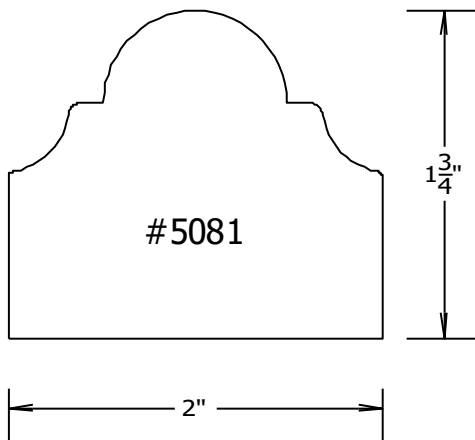
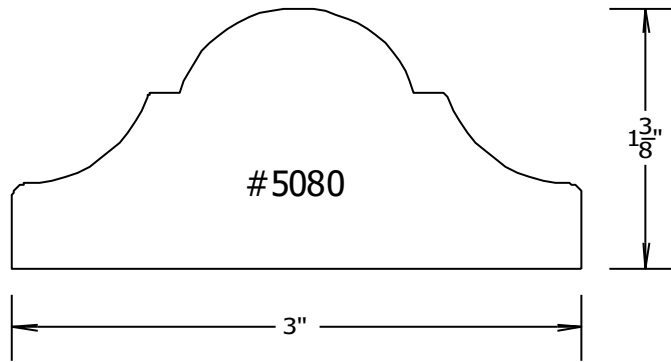
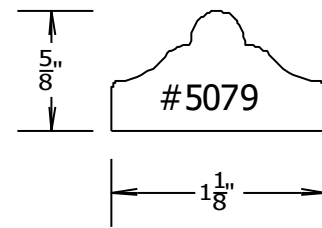
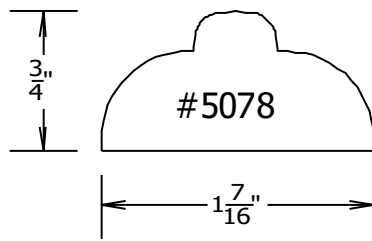
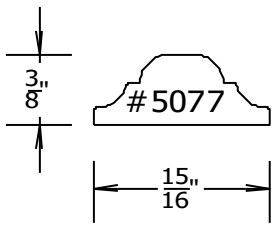
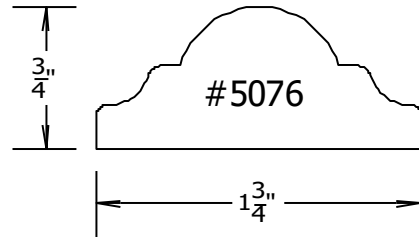
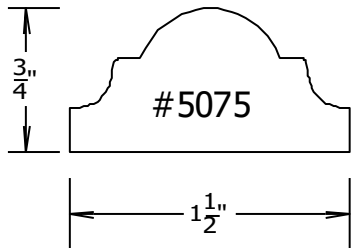



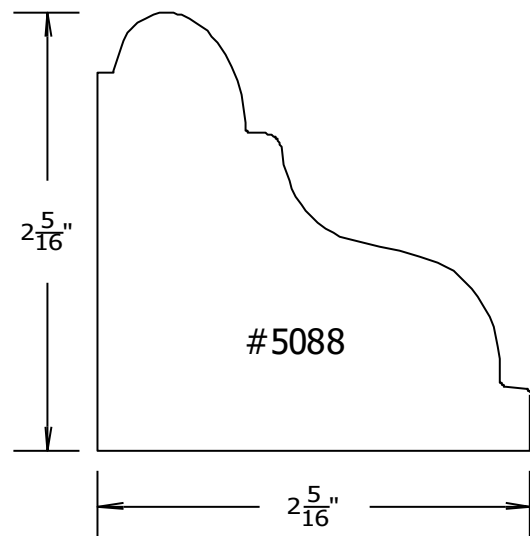
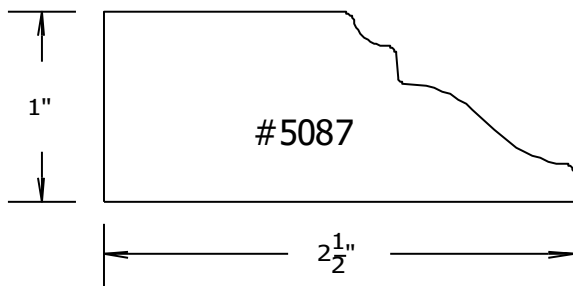
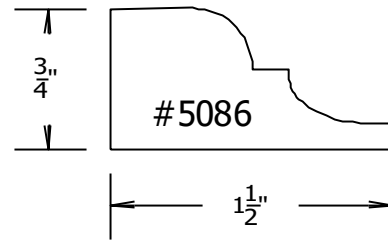
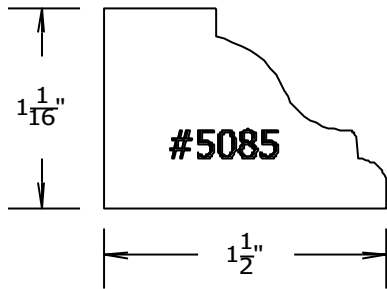
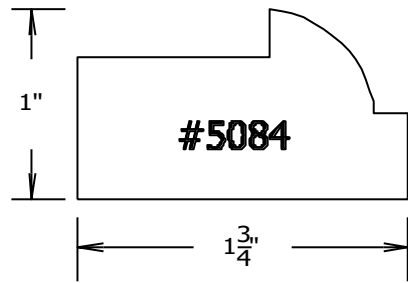
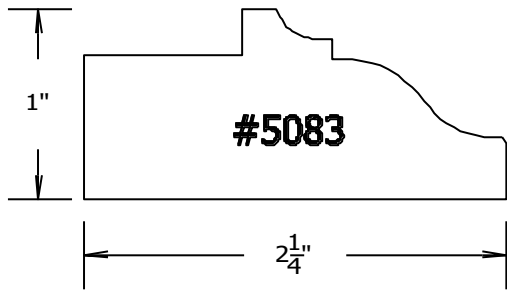

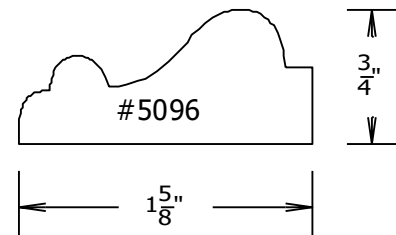
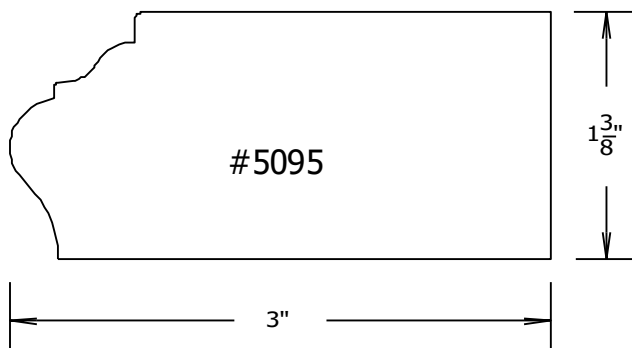
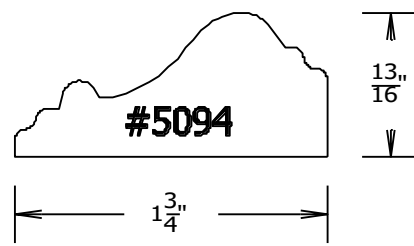
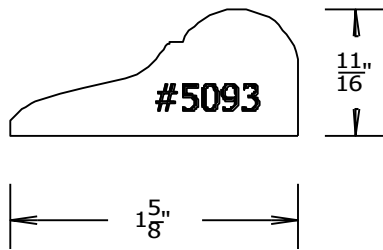
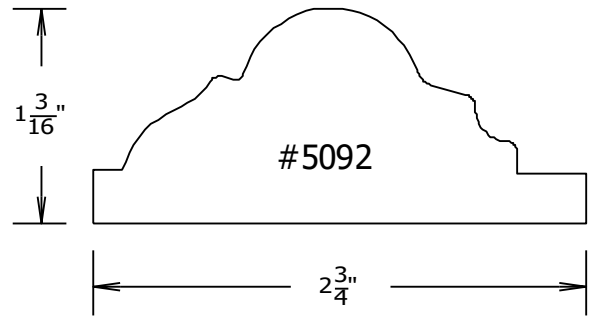
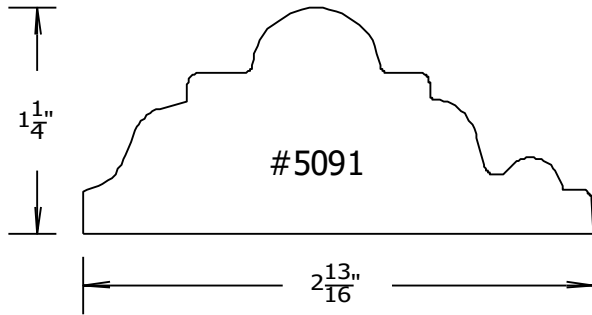
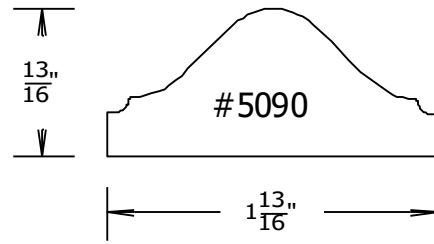
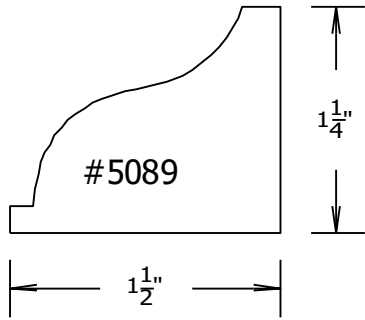

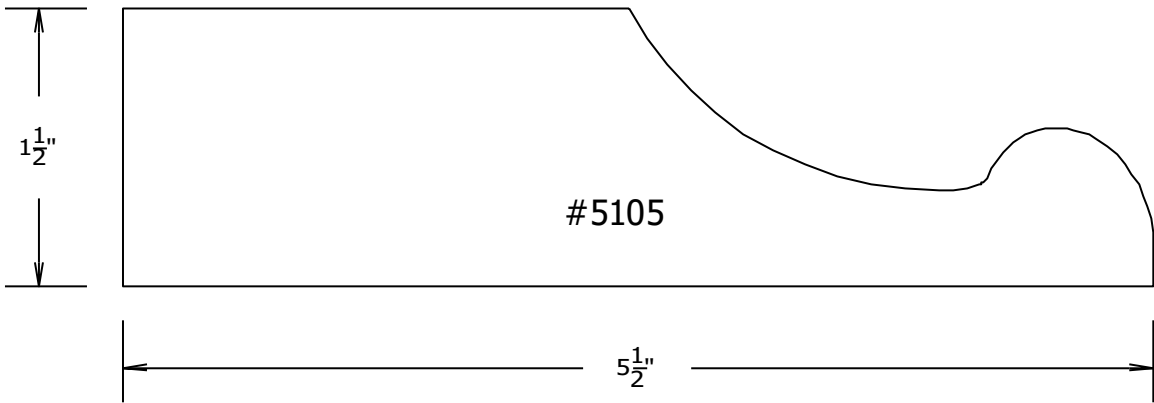
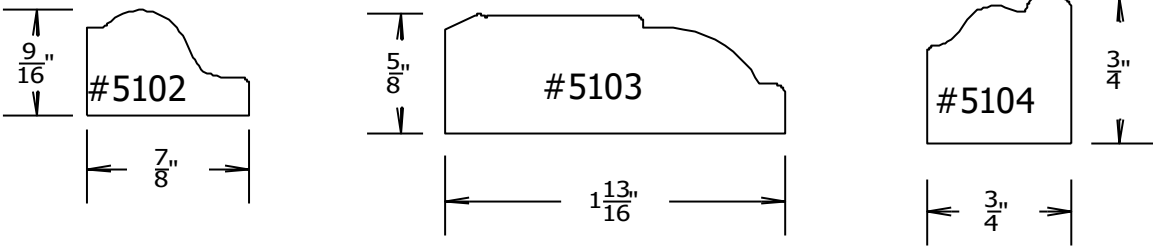
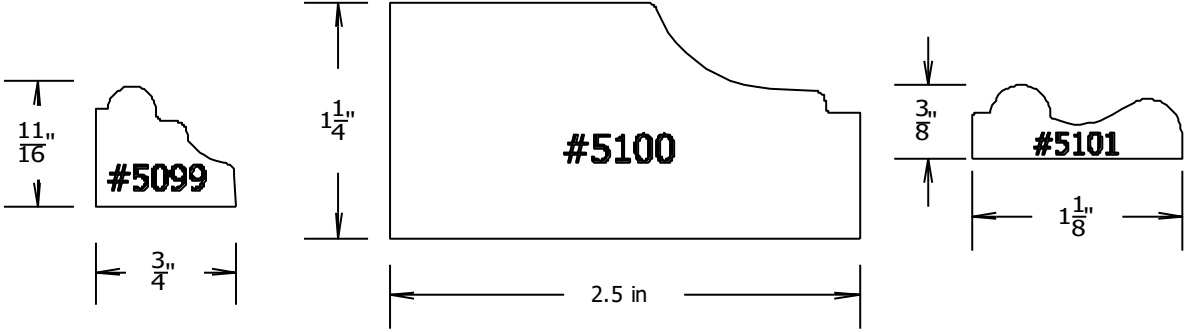
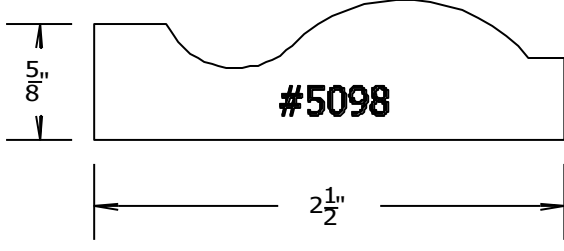
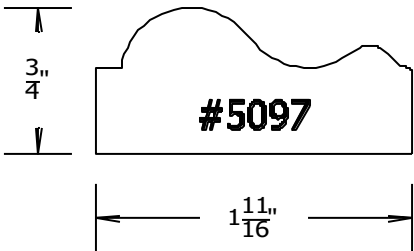

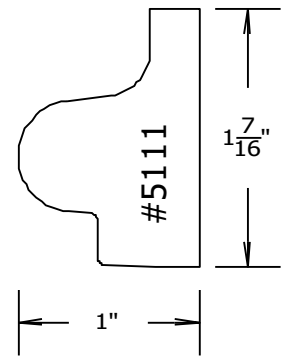
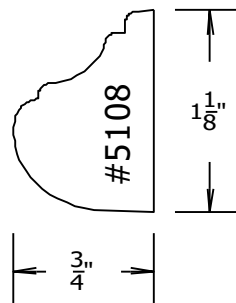
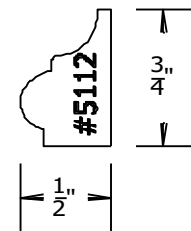
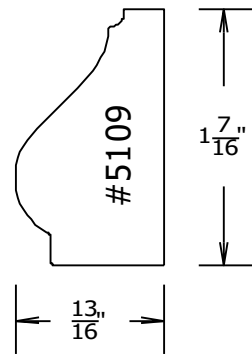
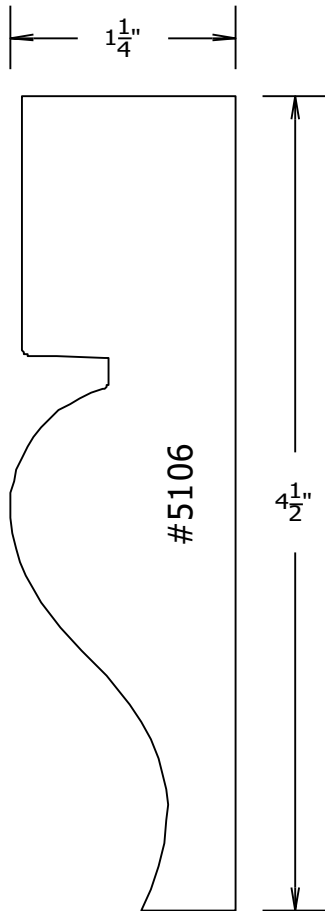
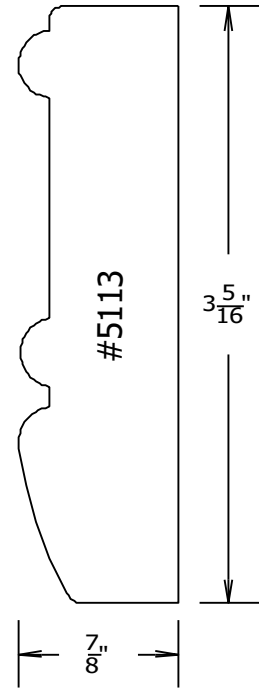
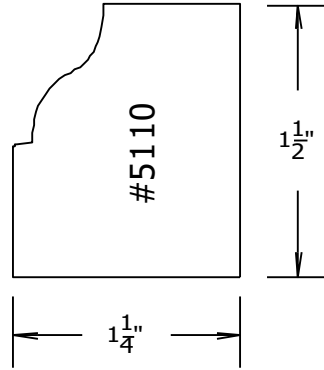
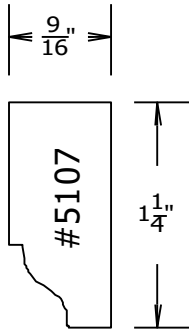

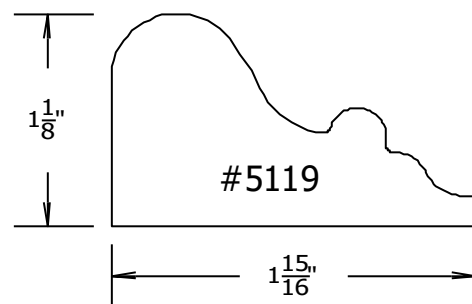
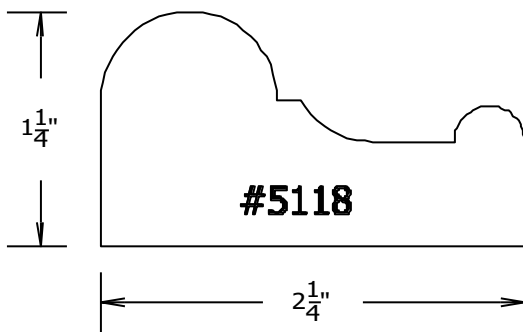
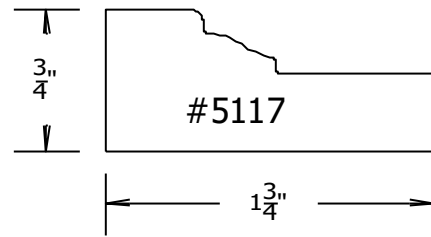
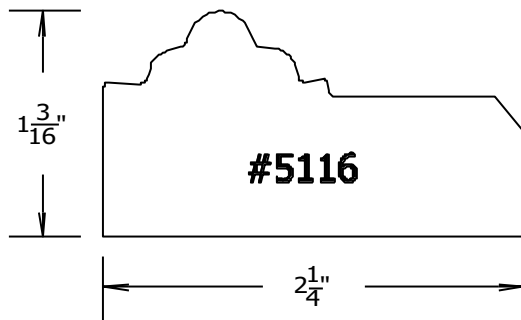
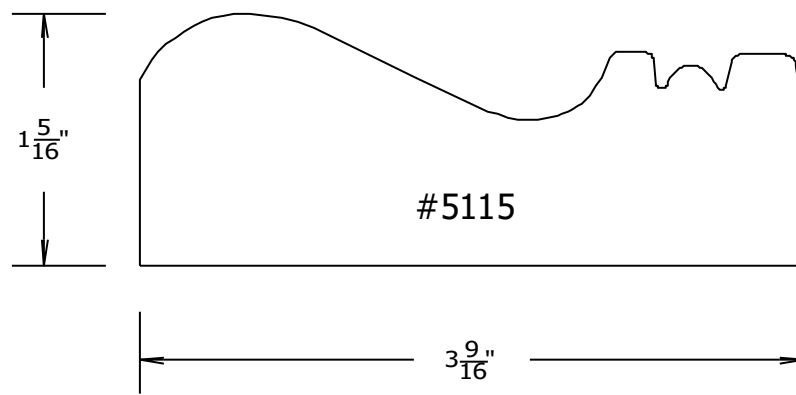
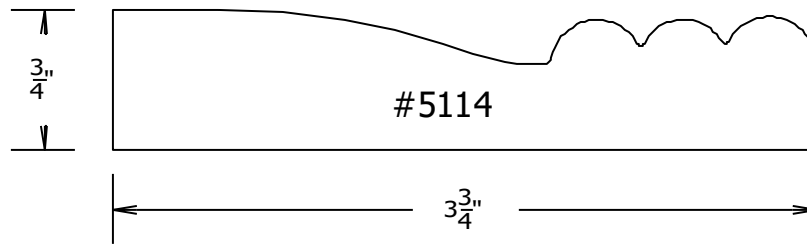

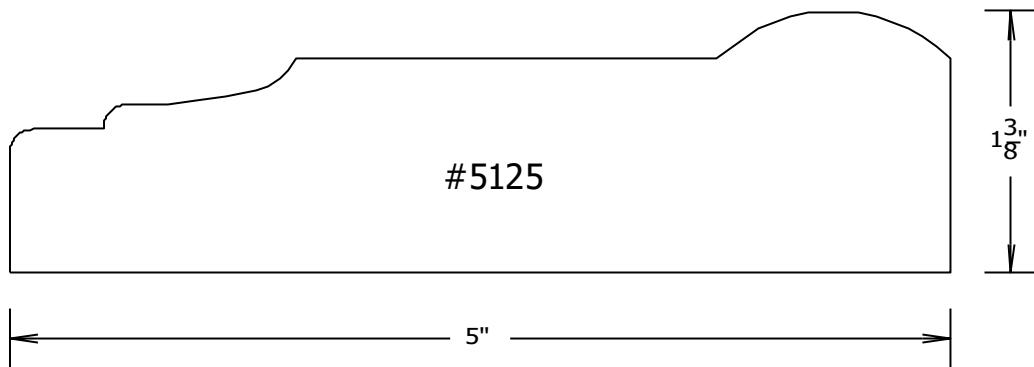
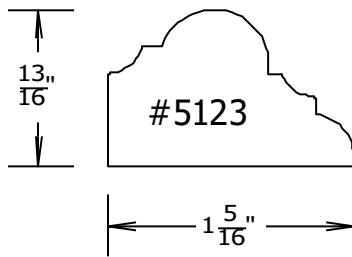
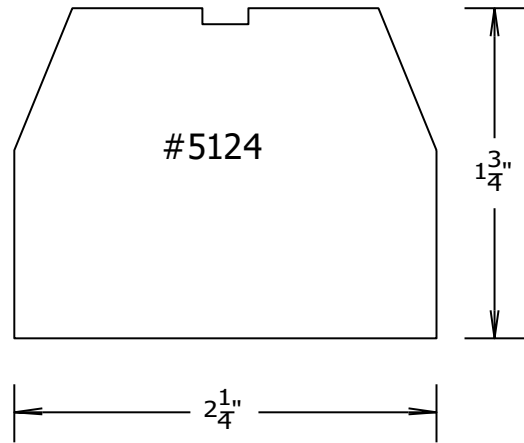
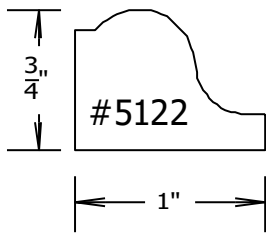
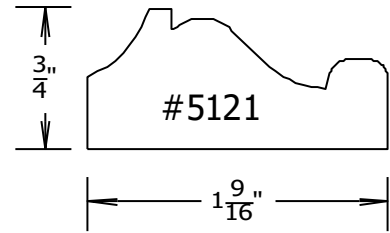
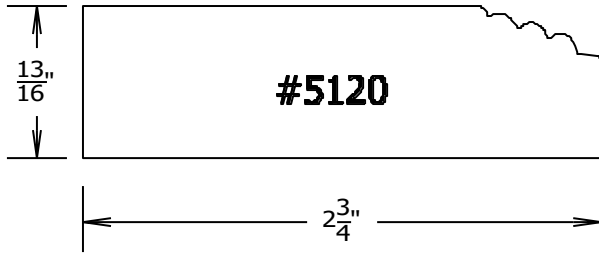

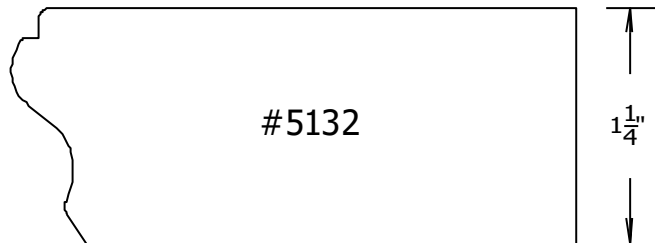
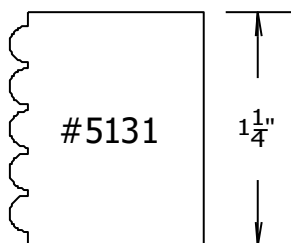
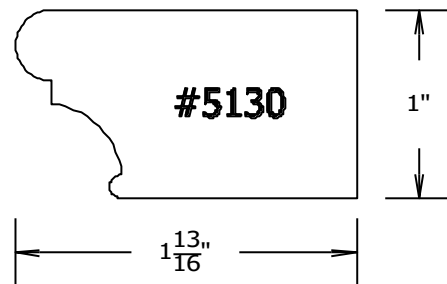
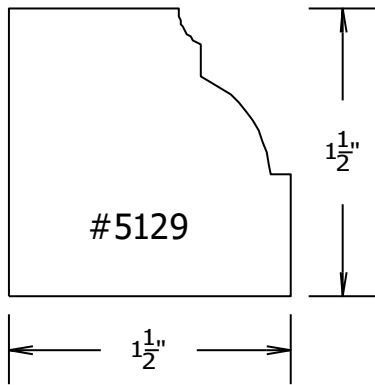
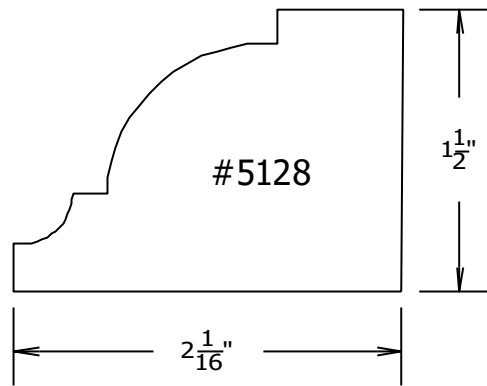
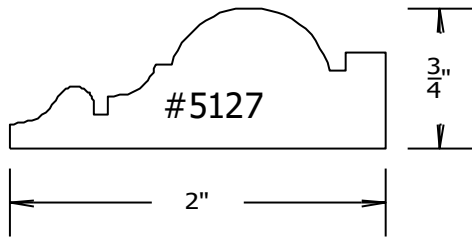
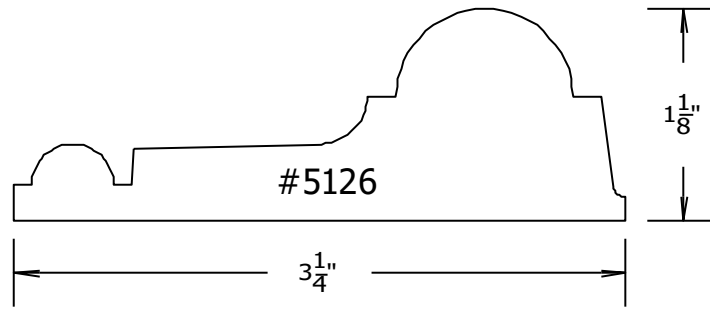

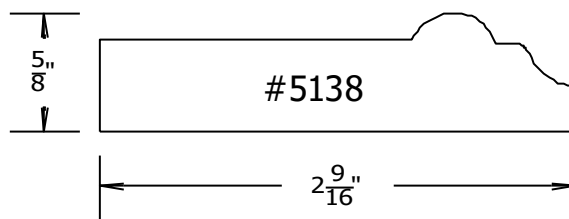
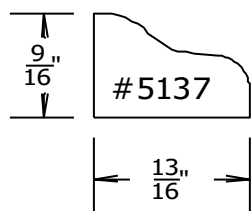
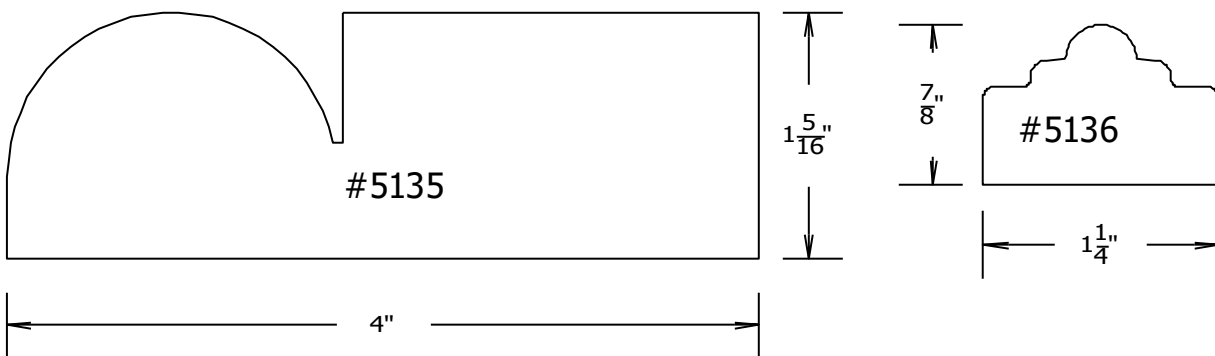
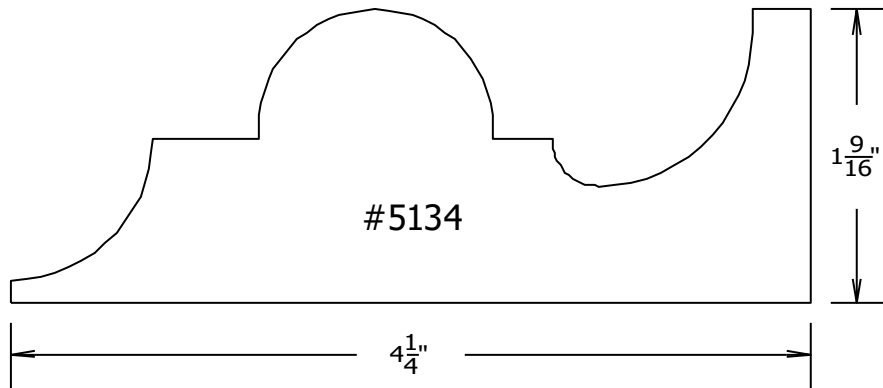
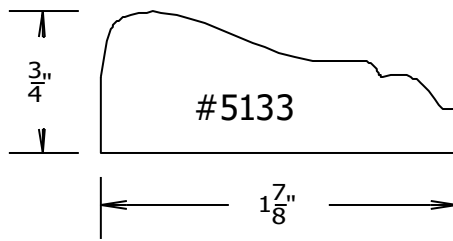



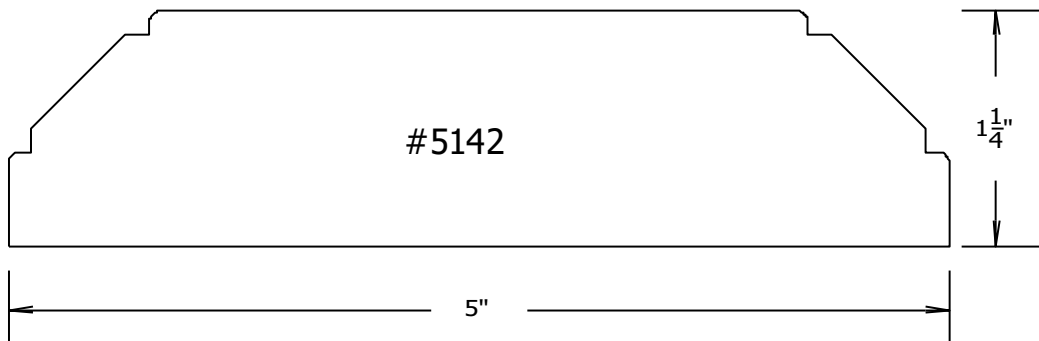
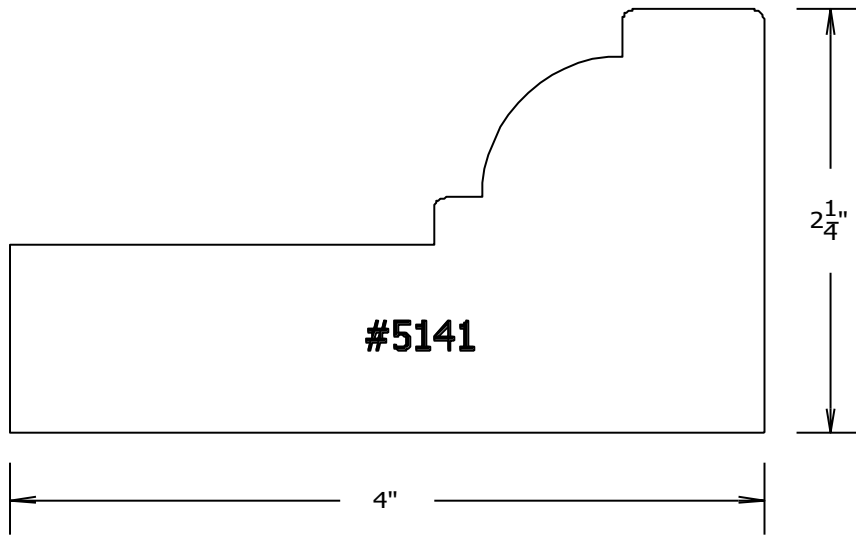
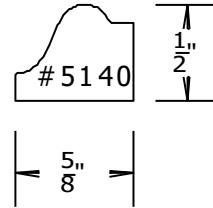
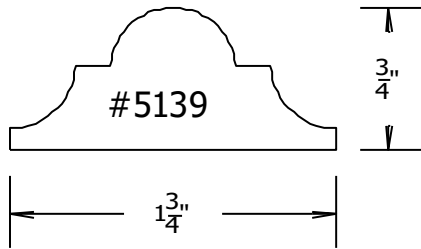

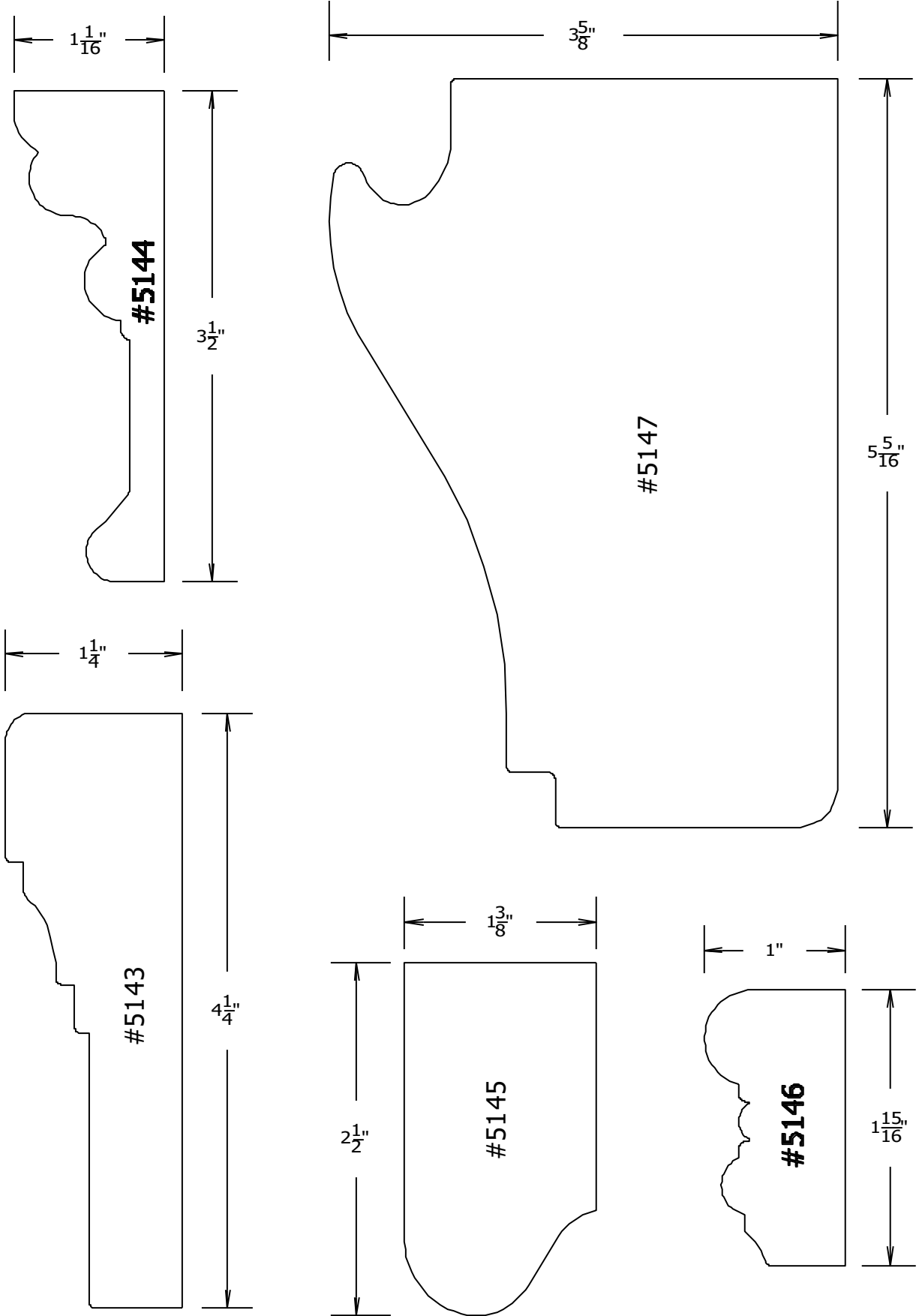

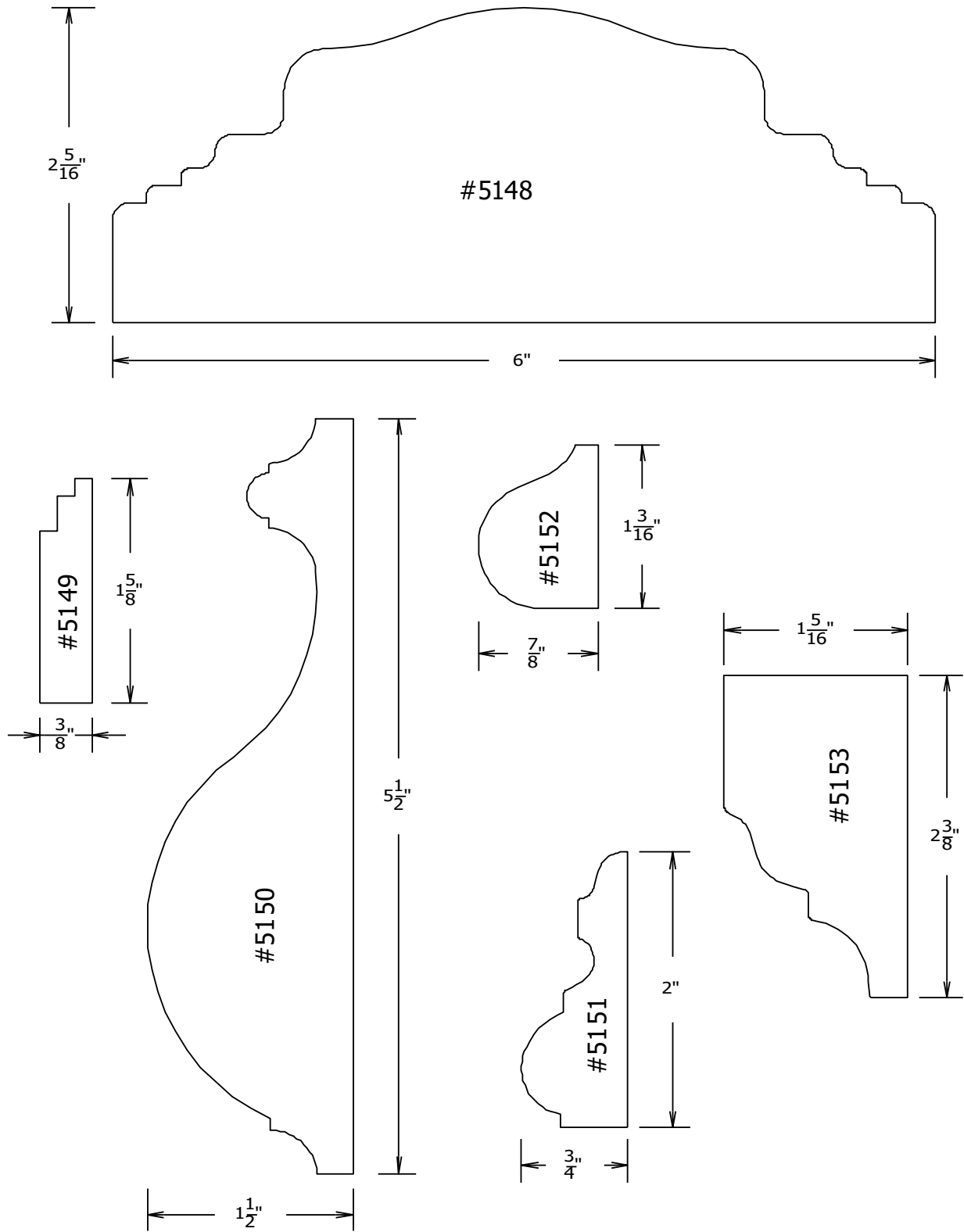

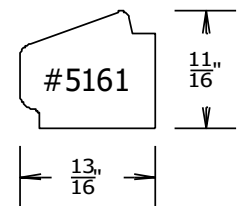
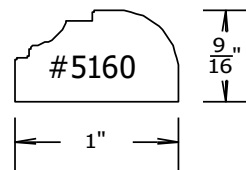
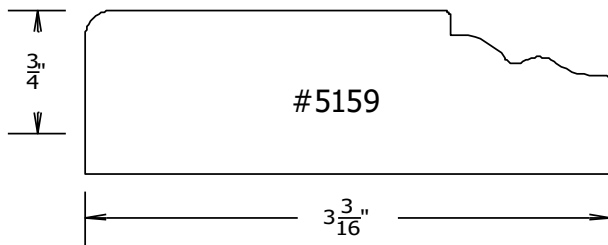
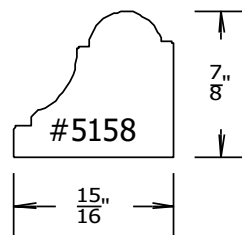
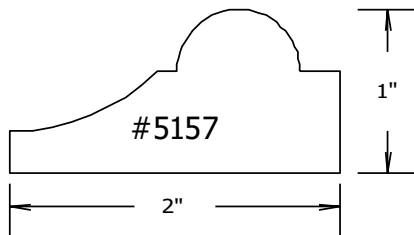
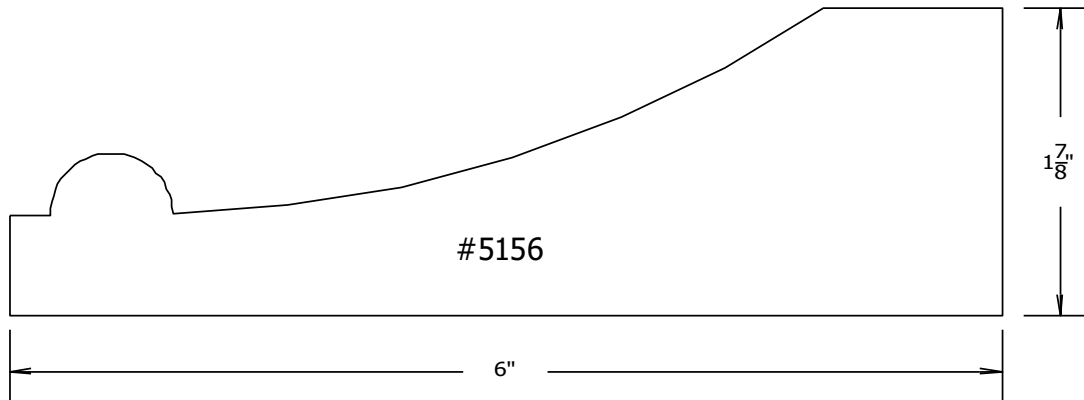
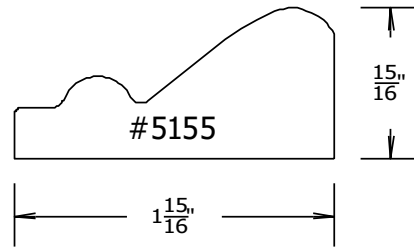
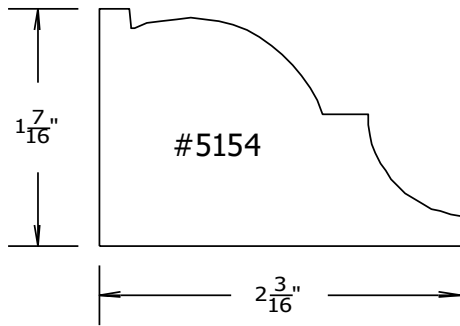

Applied Mouldings Page #25

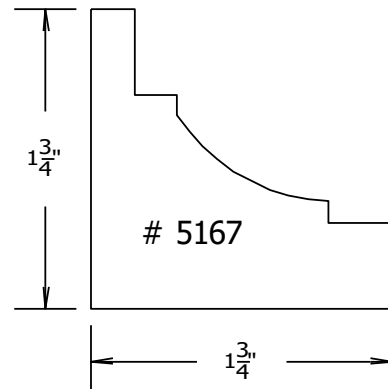
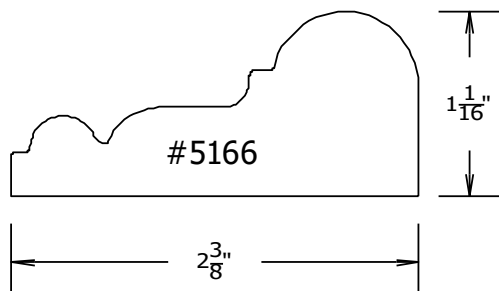
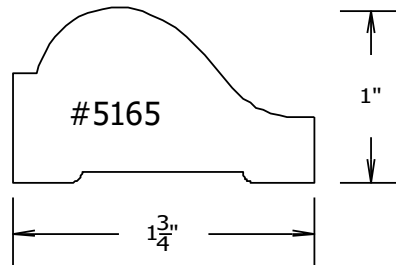
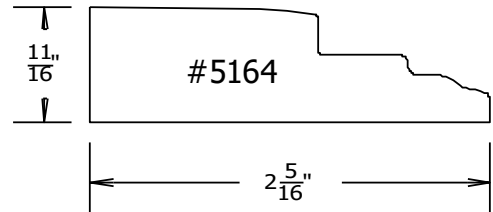
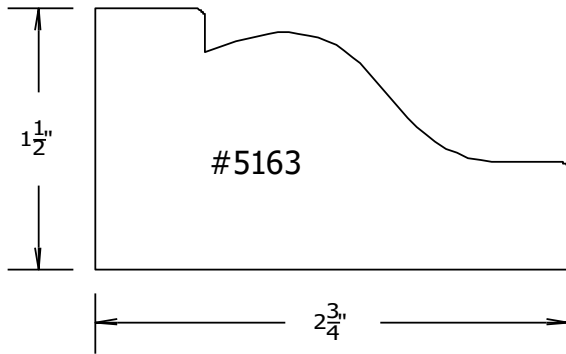
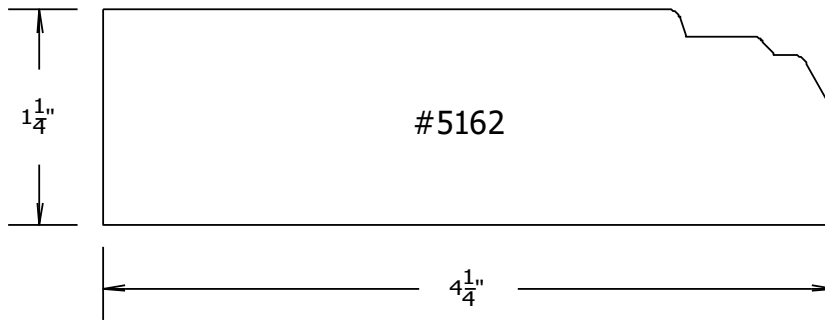

Applied Mouldings Page #26

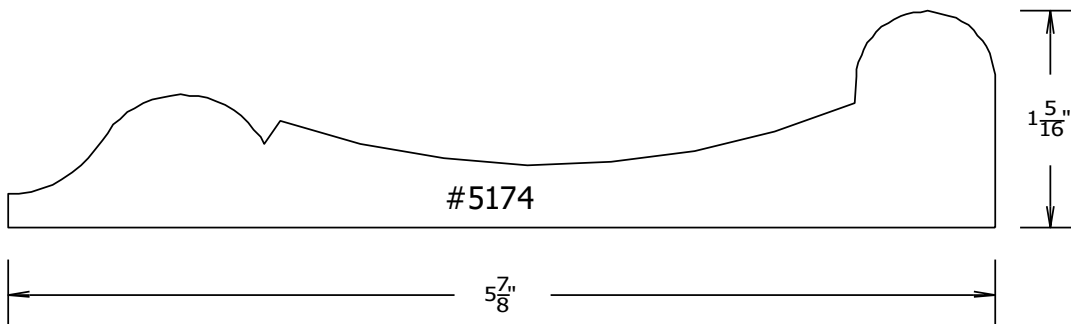
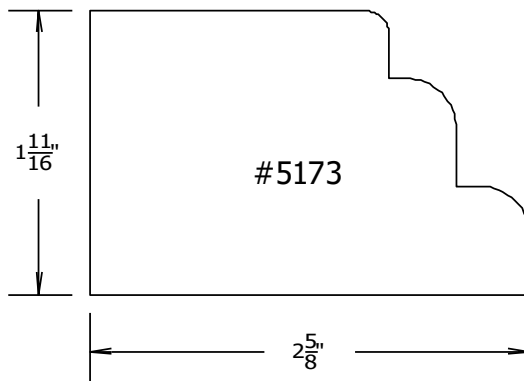
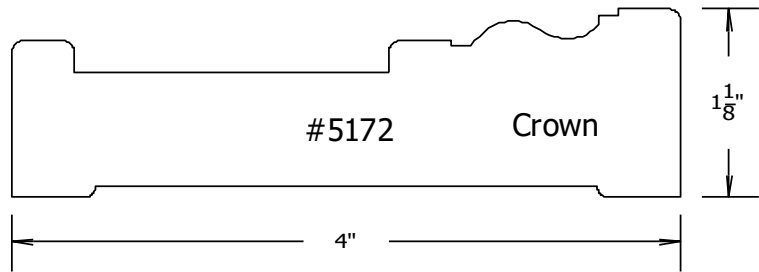
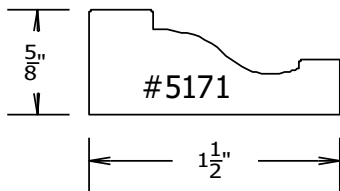
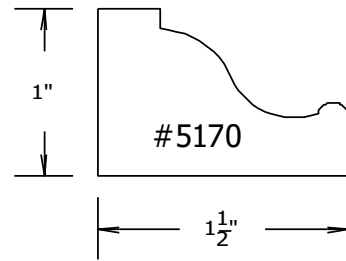
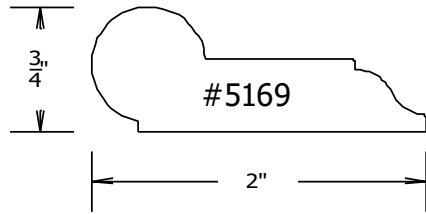
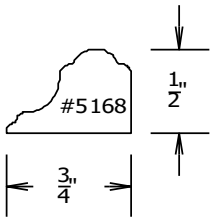

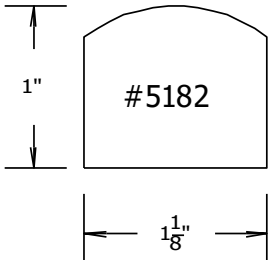
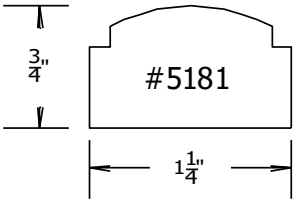
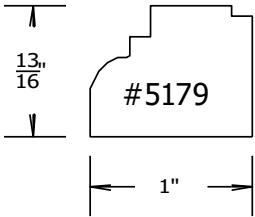
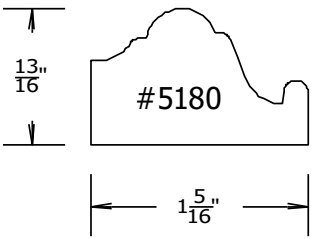
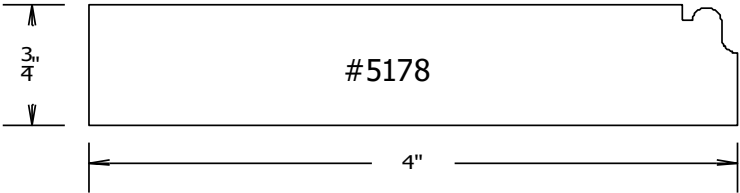
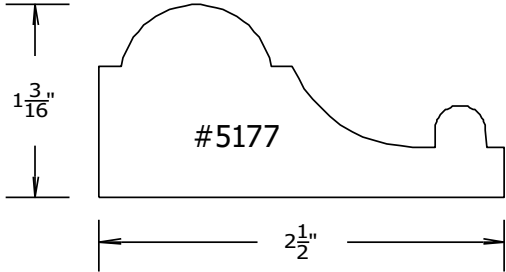
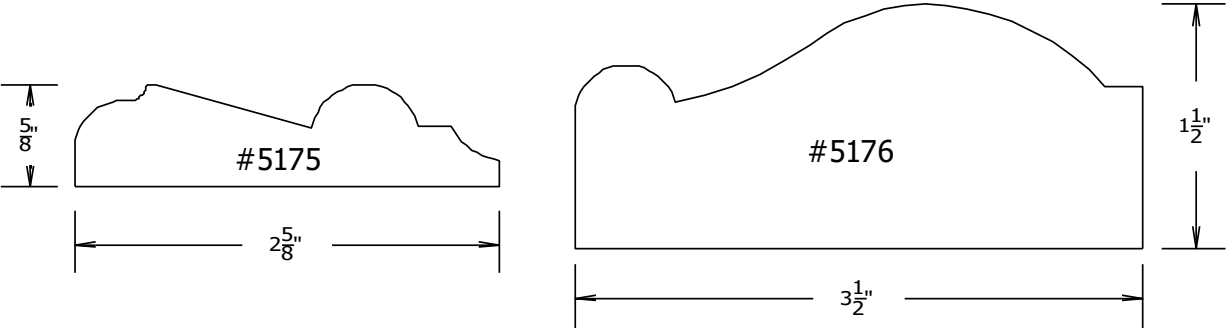

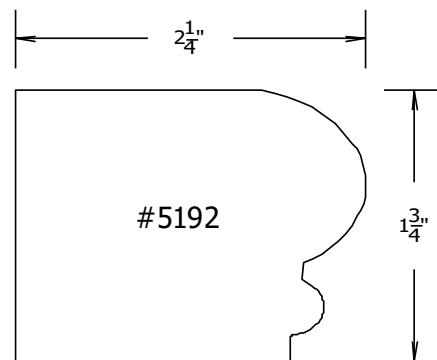
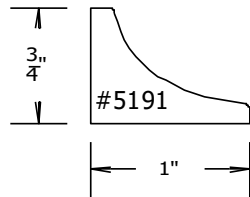
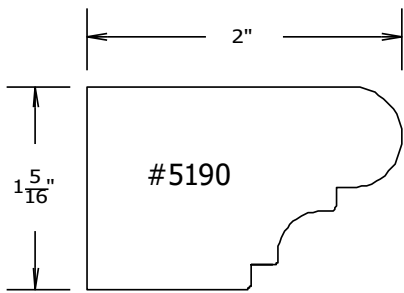
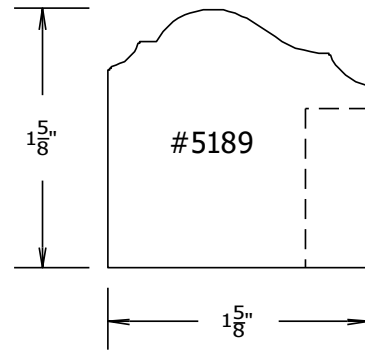
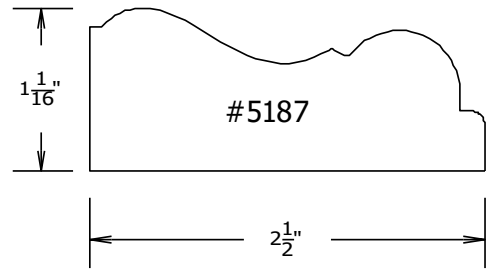
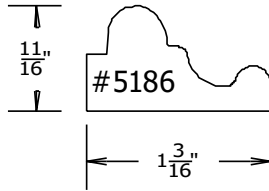
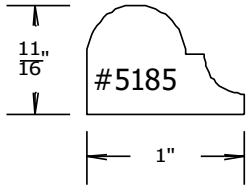
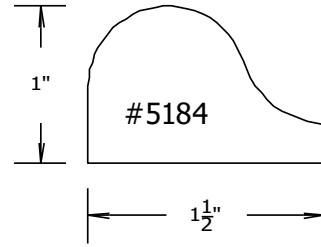
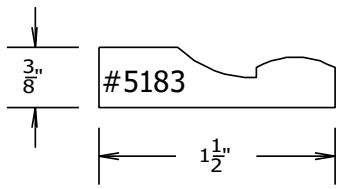



Applied Mouldings Page #29

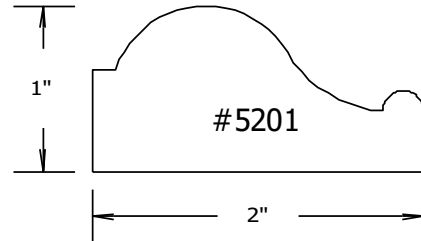
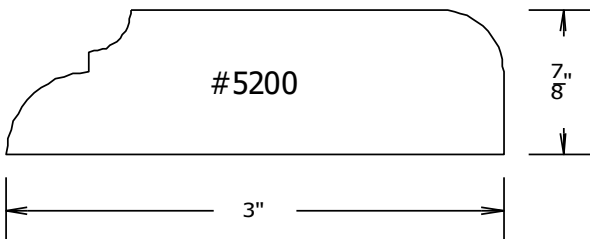
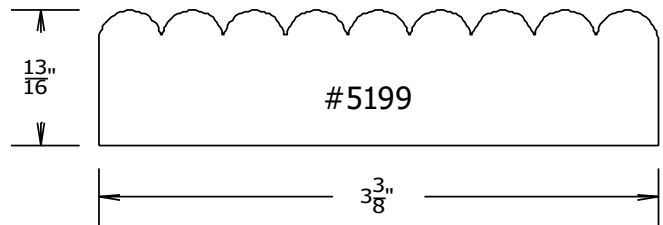
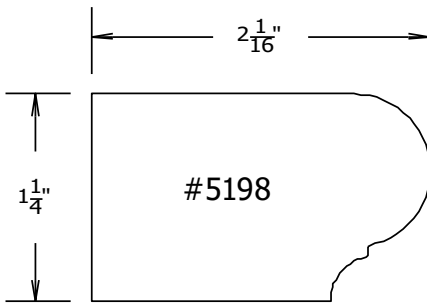
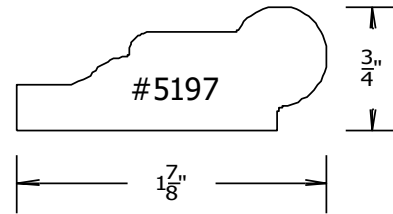
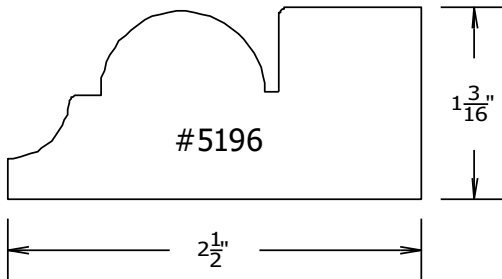
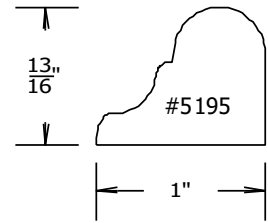
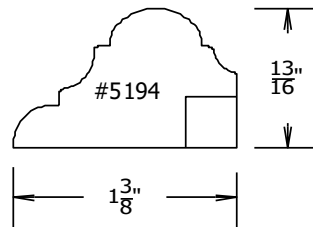
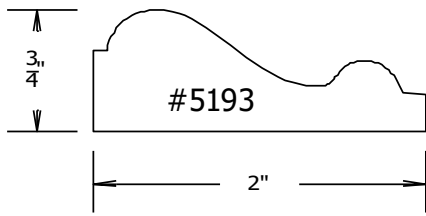

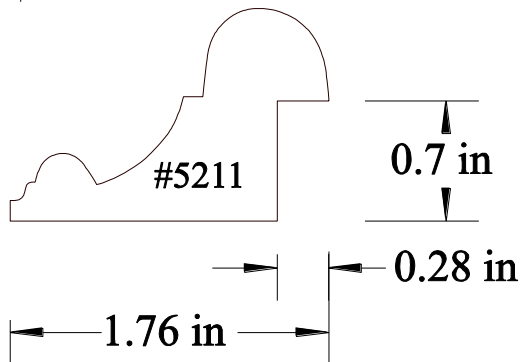
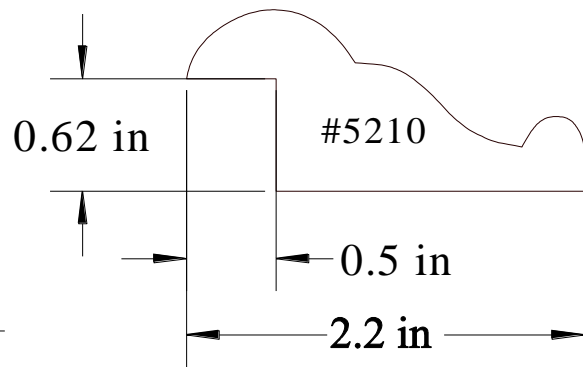
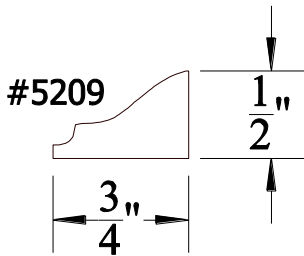
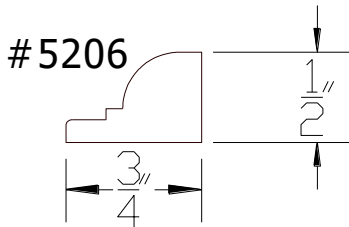
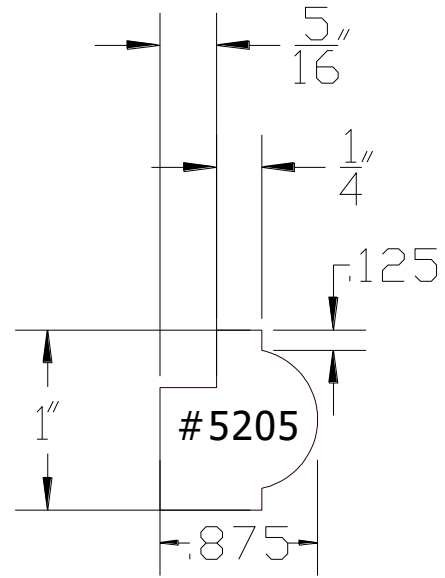
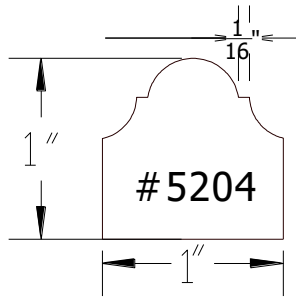
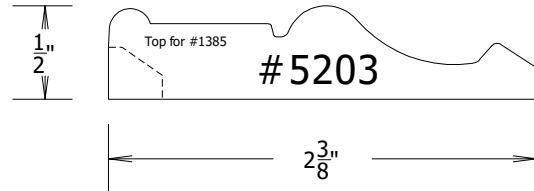
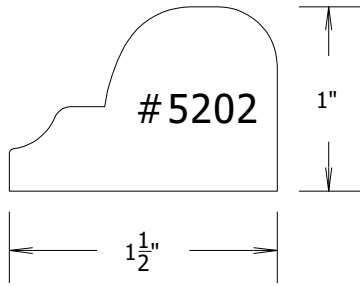

Applied Mouldings Page #31

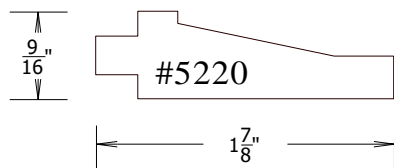
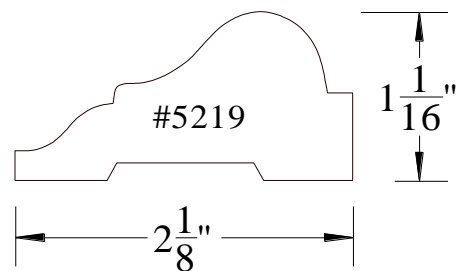
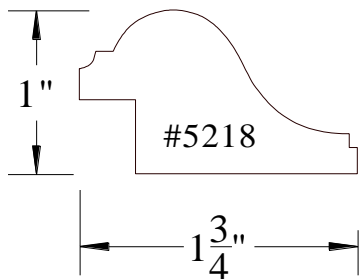
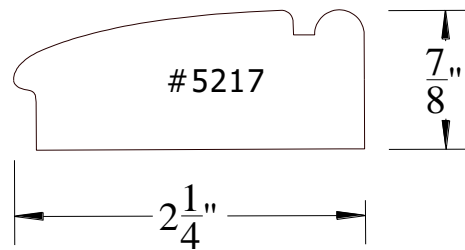
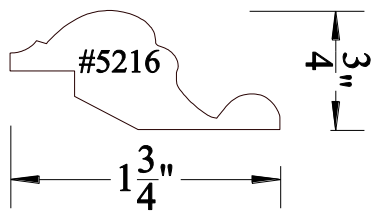
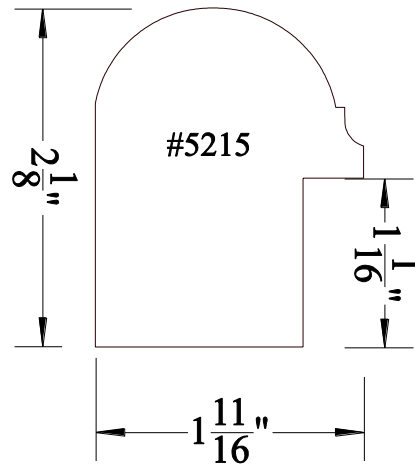
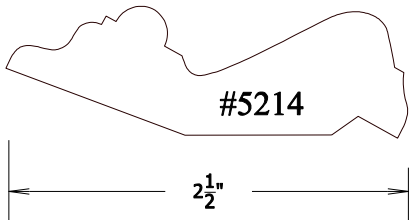
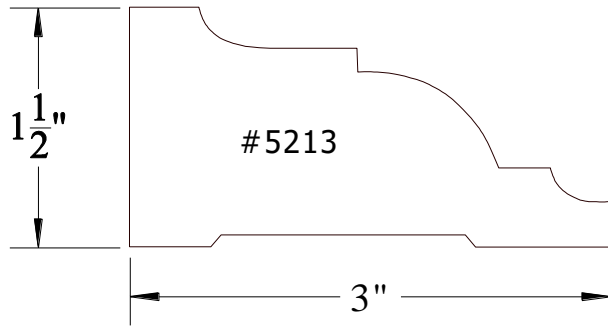
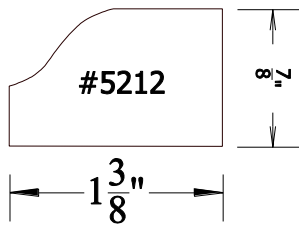

# Applied Mouldings Page #32

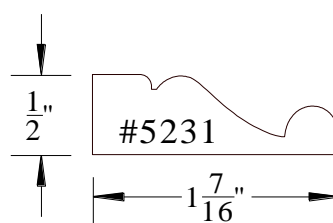
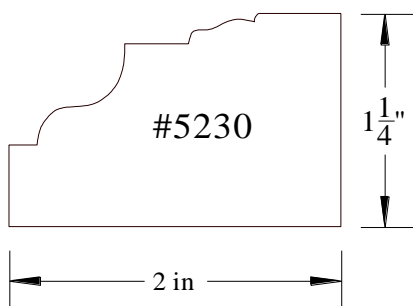
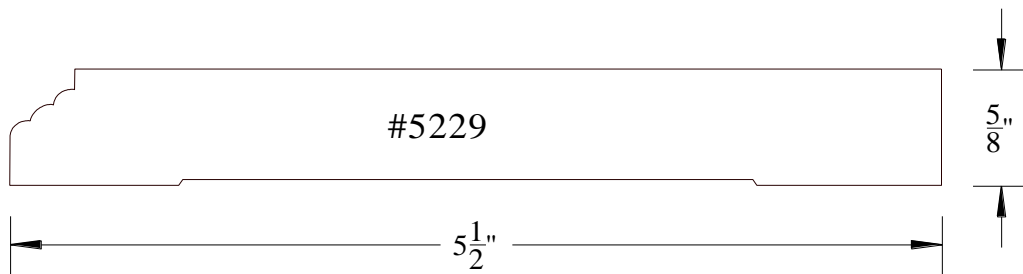
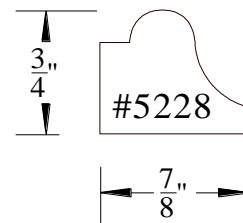
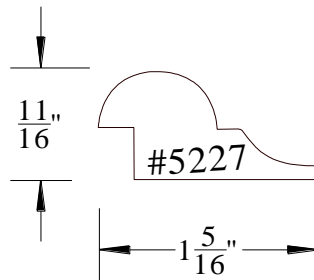
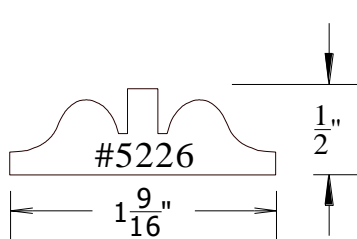
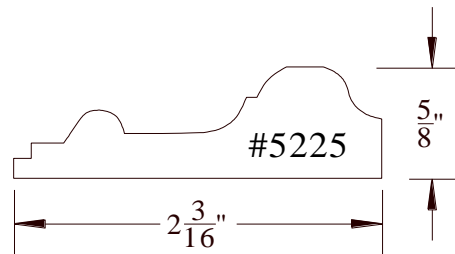
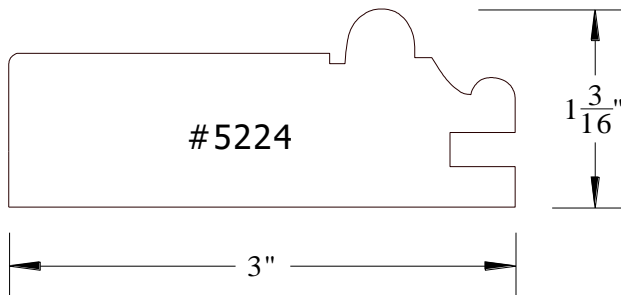
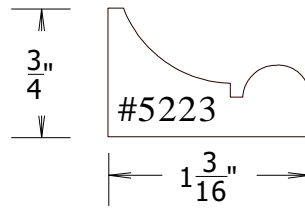
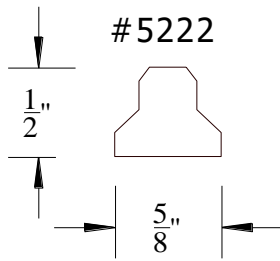
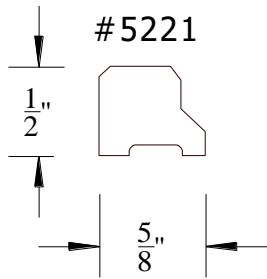

Applied Mouldings Page #33

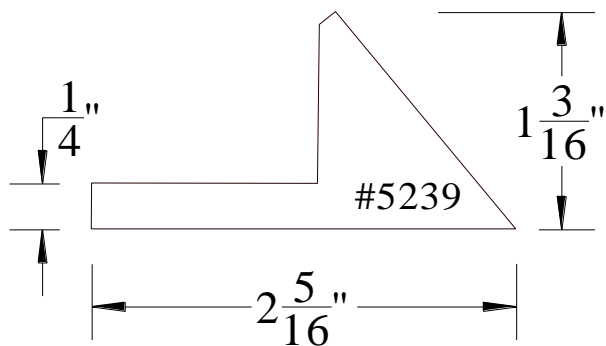
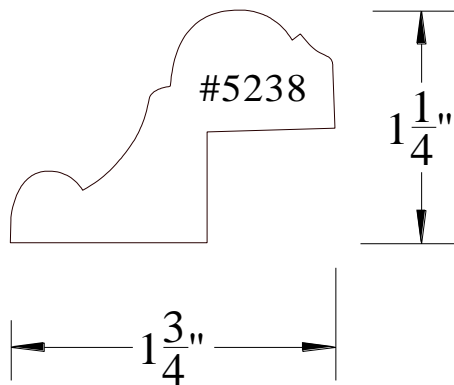
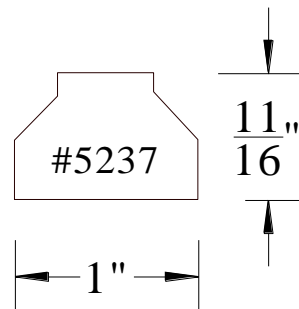
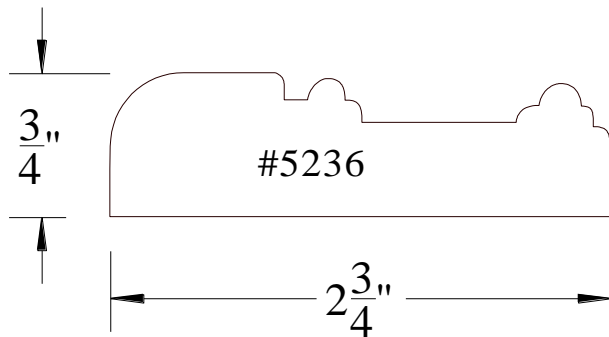
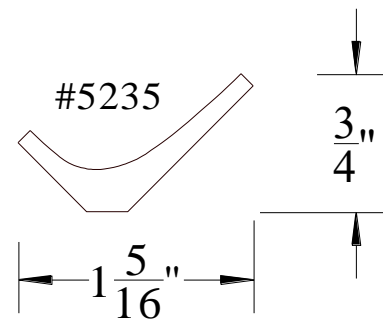
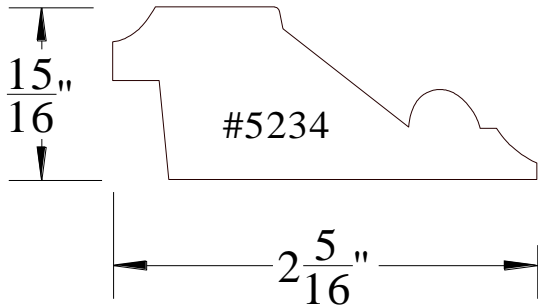
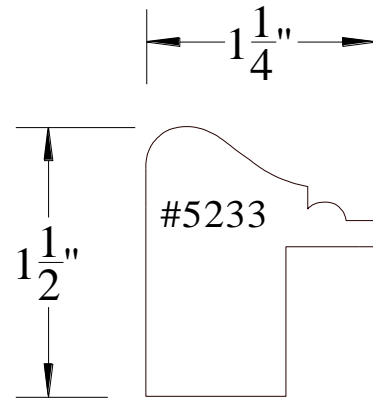
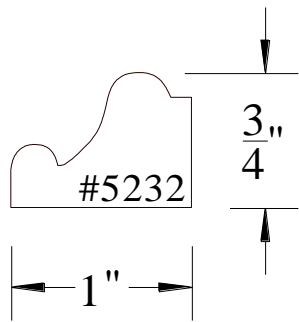

Applied Mouldings Page #34

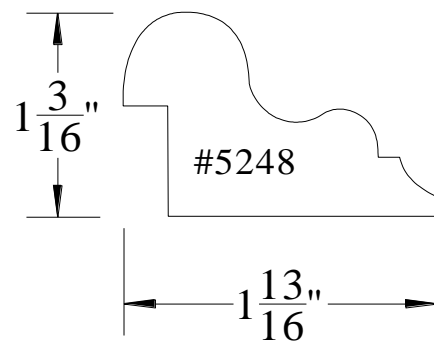
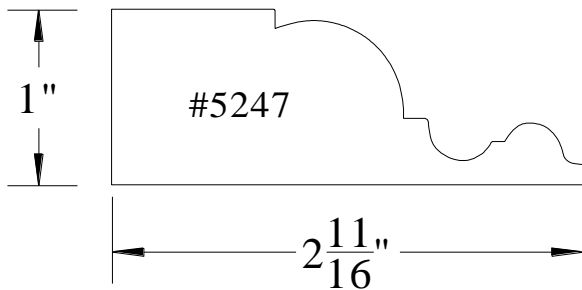
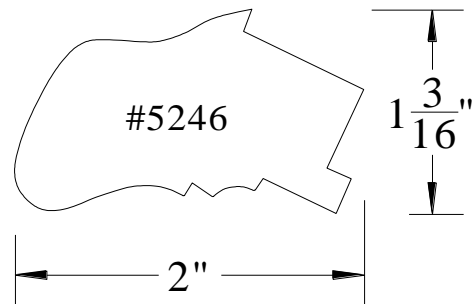
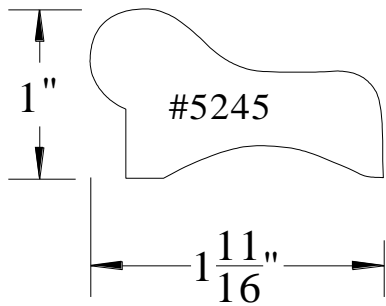
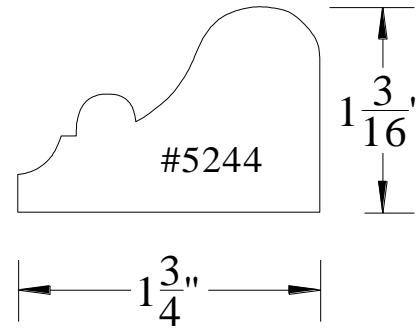
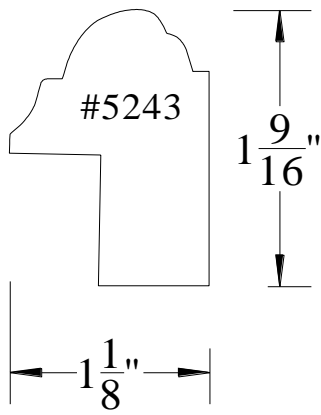
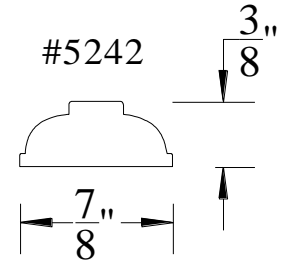
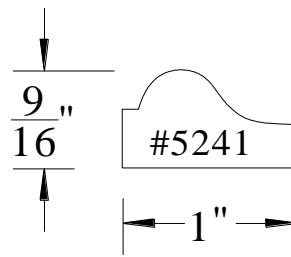
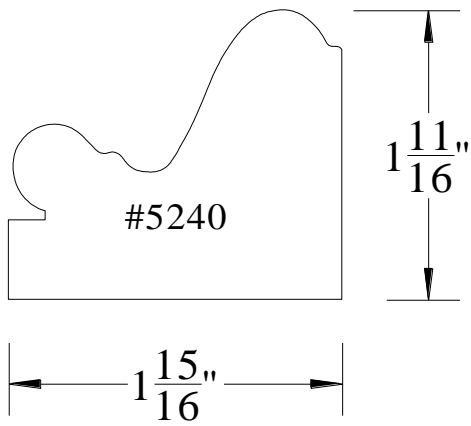



# Handrail Pages

Some modification is available on handrails and guardrails.

Plows of any size can be added to these profiles as long as the integrity of the handrail is maintained.



# Handrail page #1

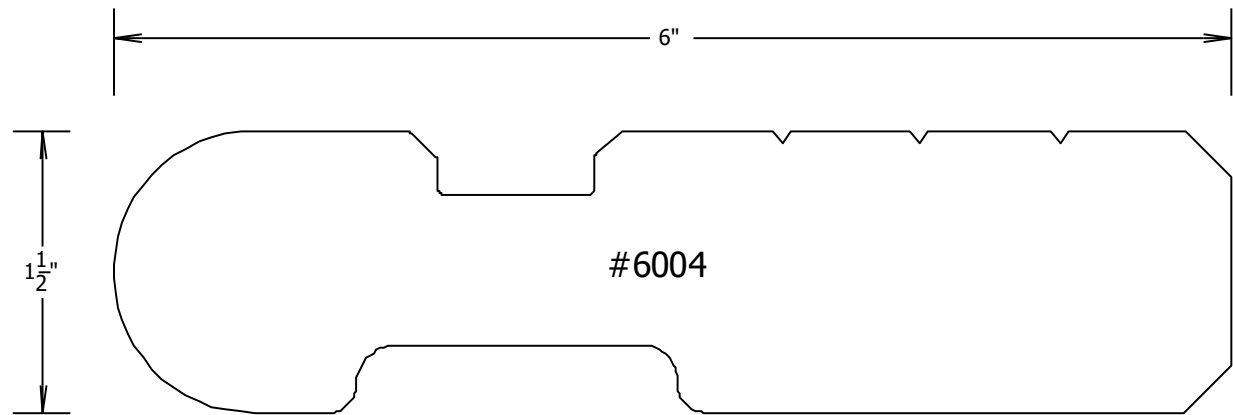
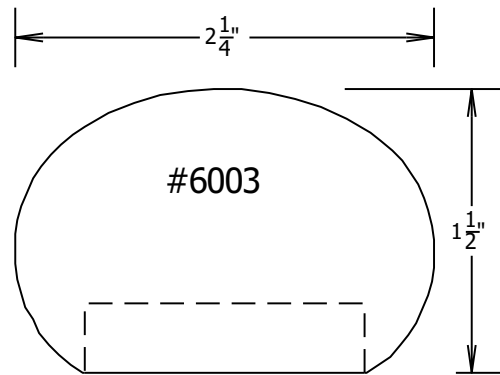
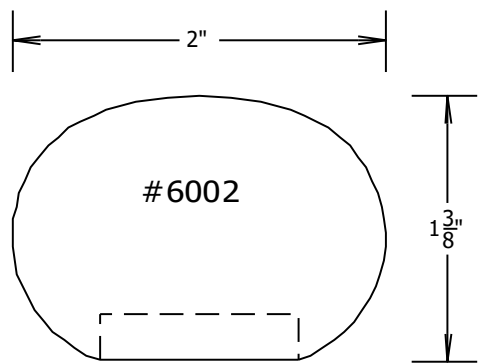
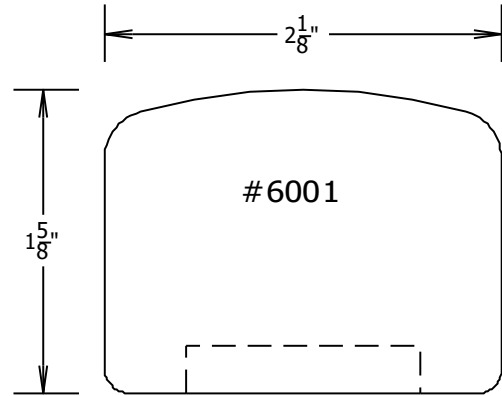
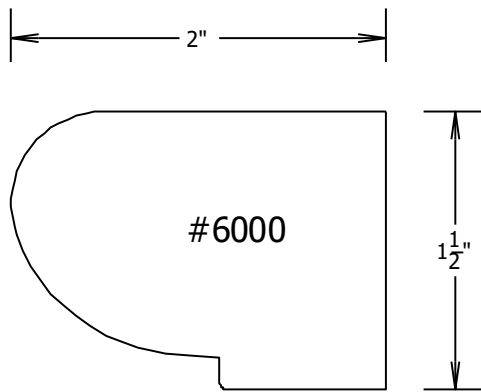

# Handrail page #2

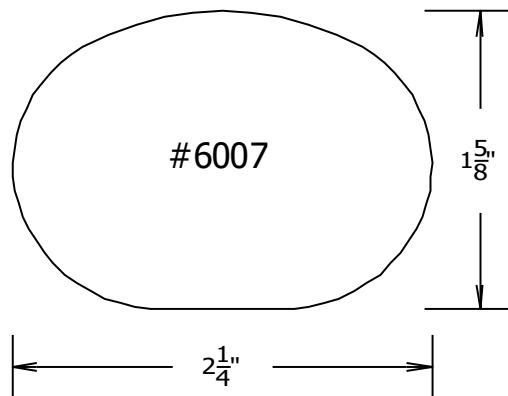
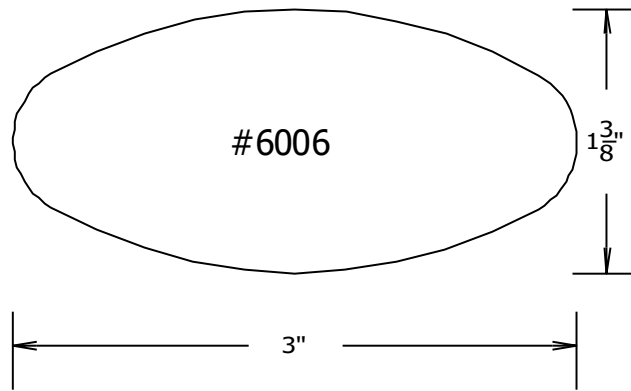
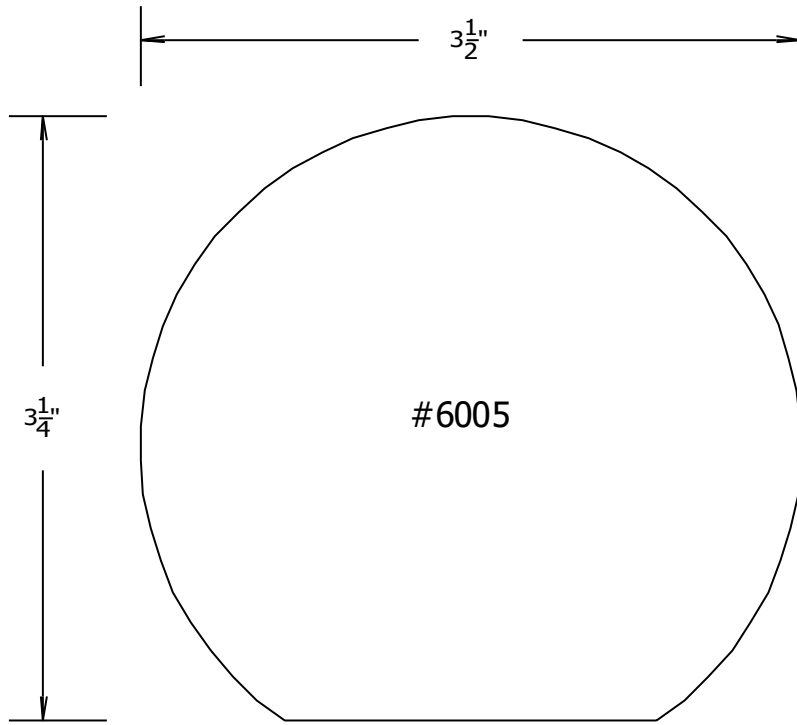

Handrail page #3

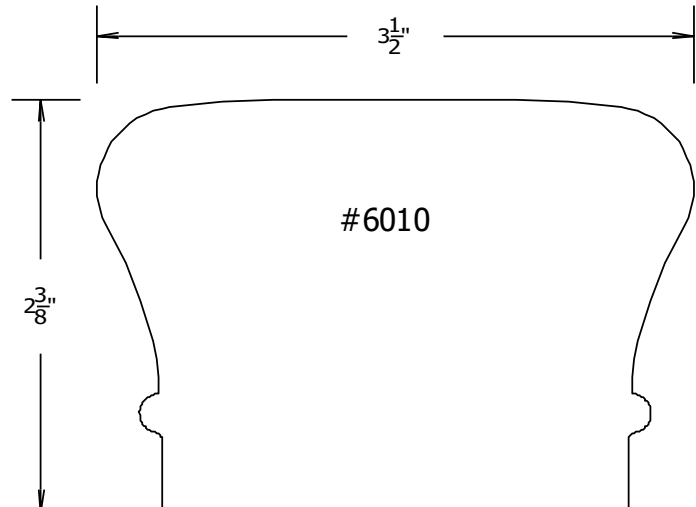
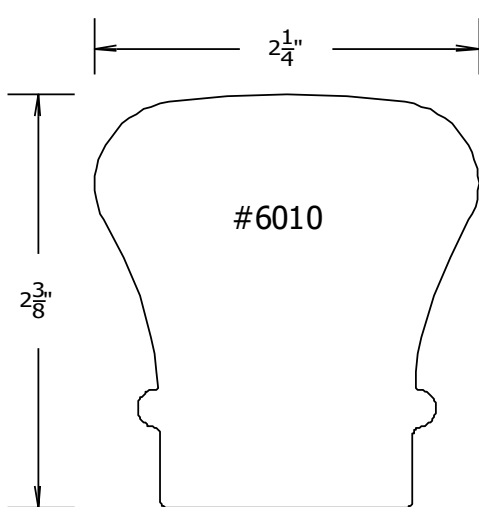
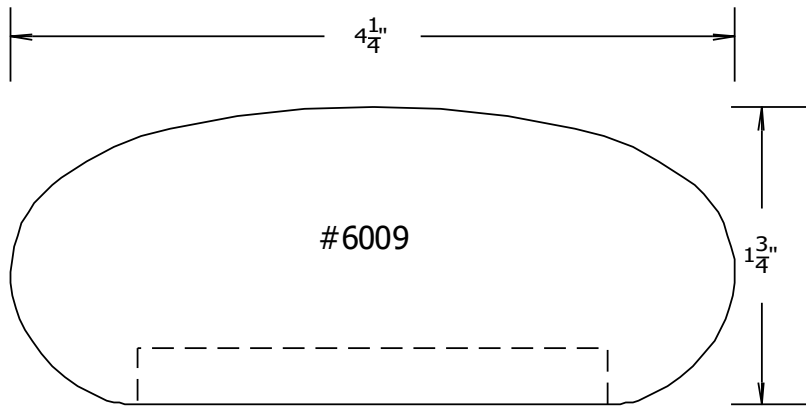
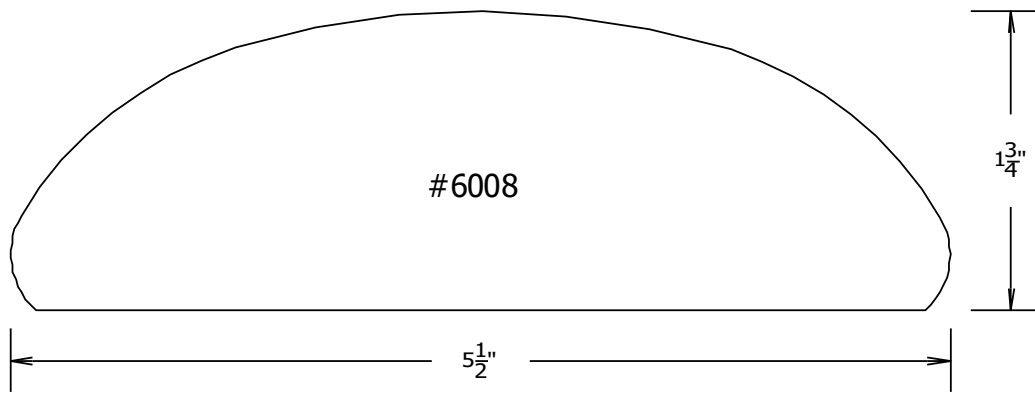

Handrail page #4

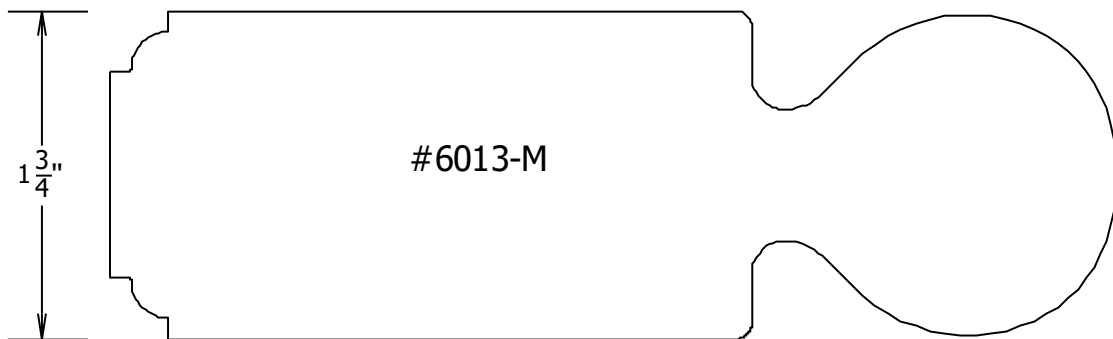
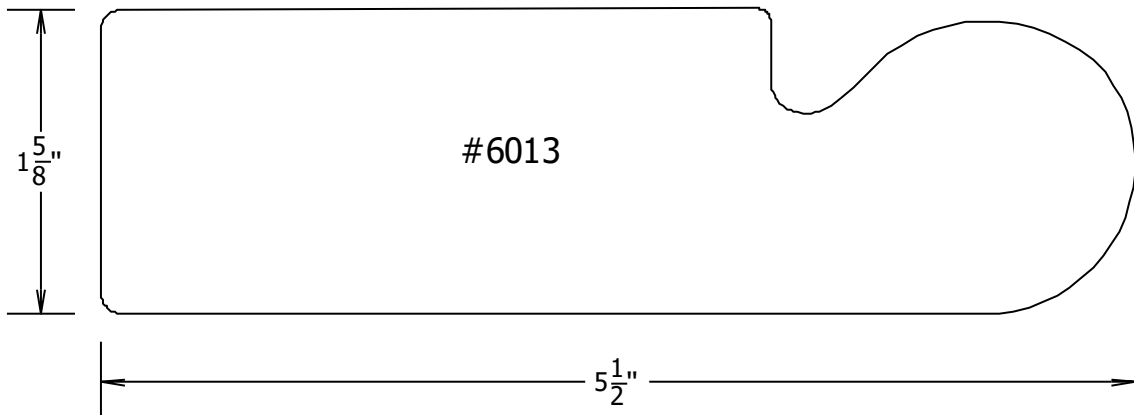
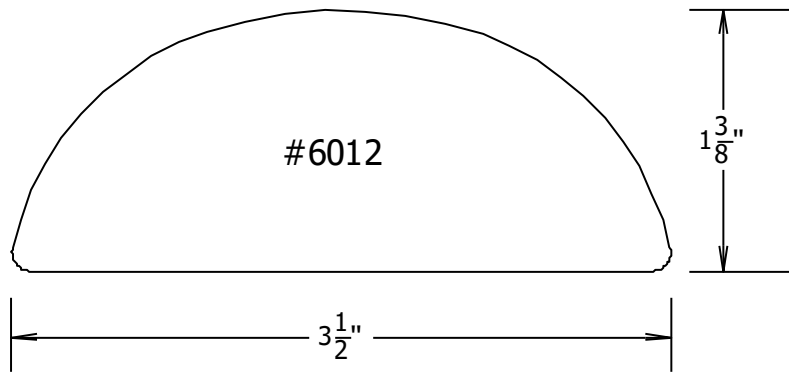
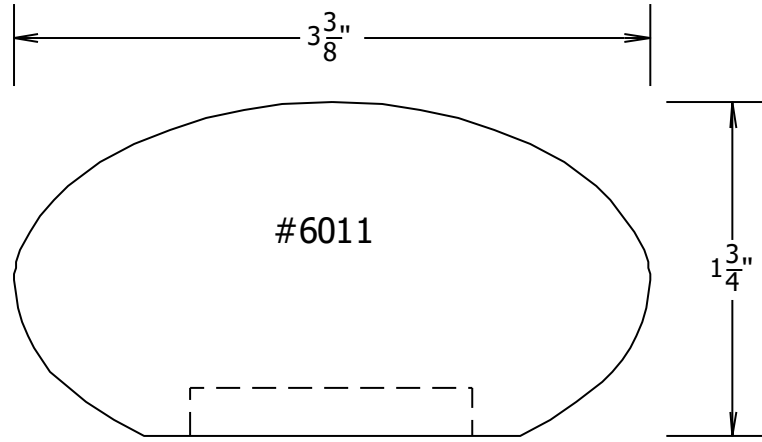

Handrail page #5

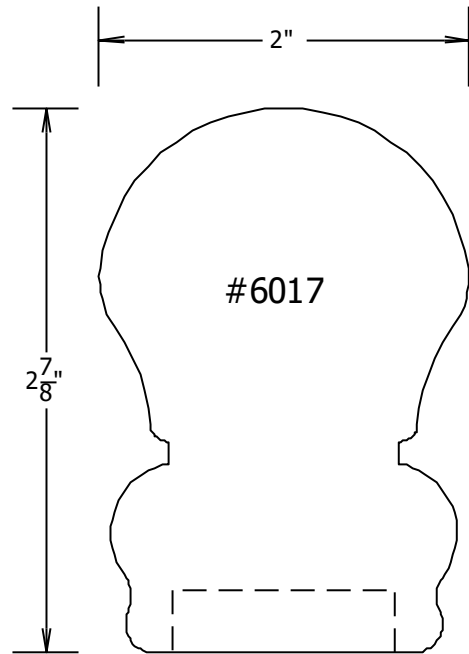
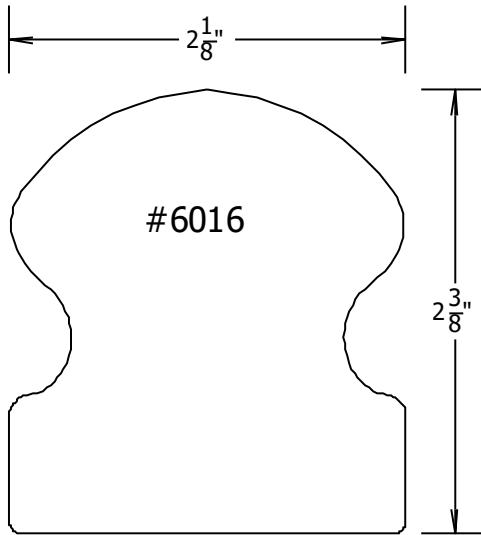
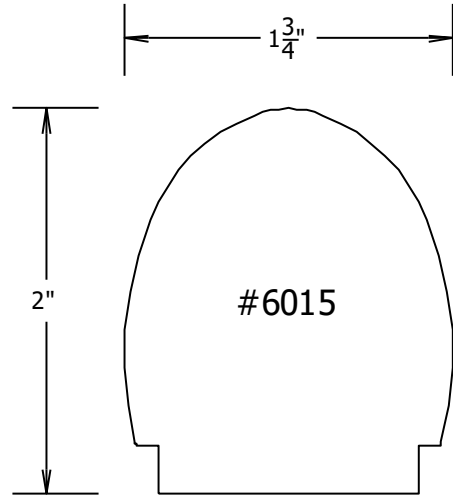
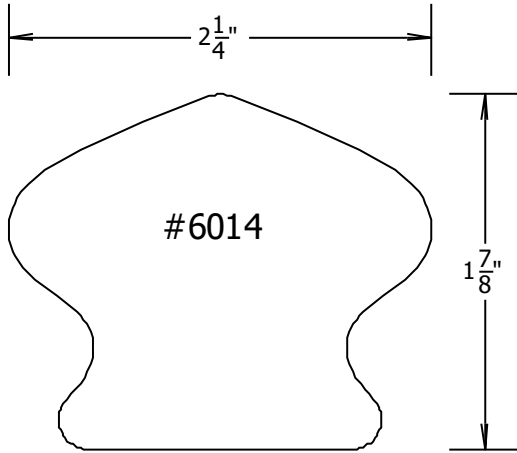

Handrail page #6

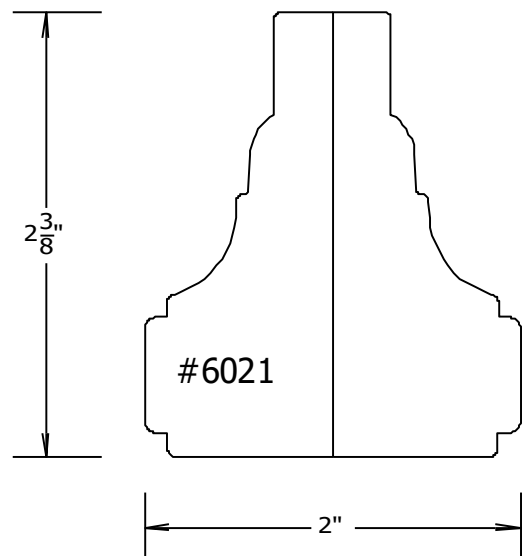
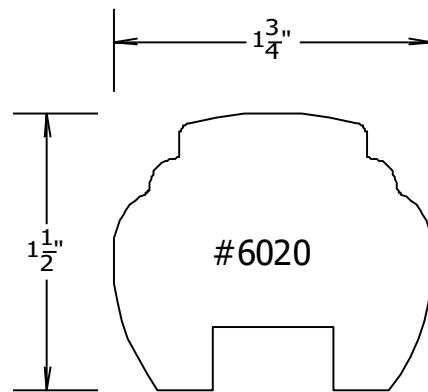
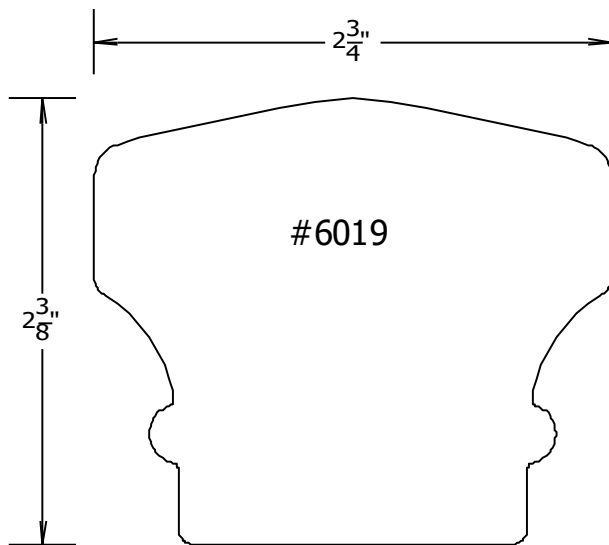
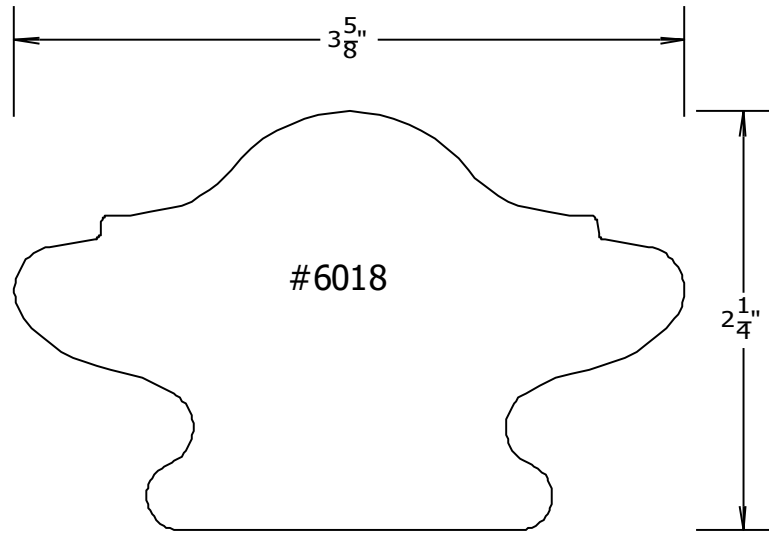

Handrail page #7

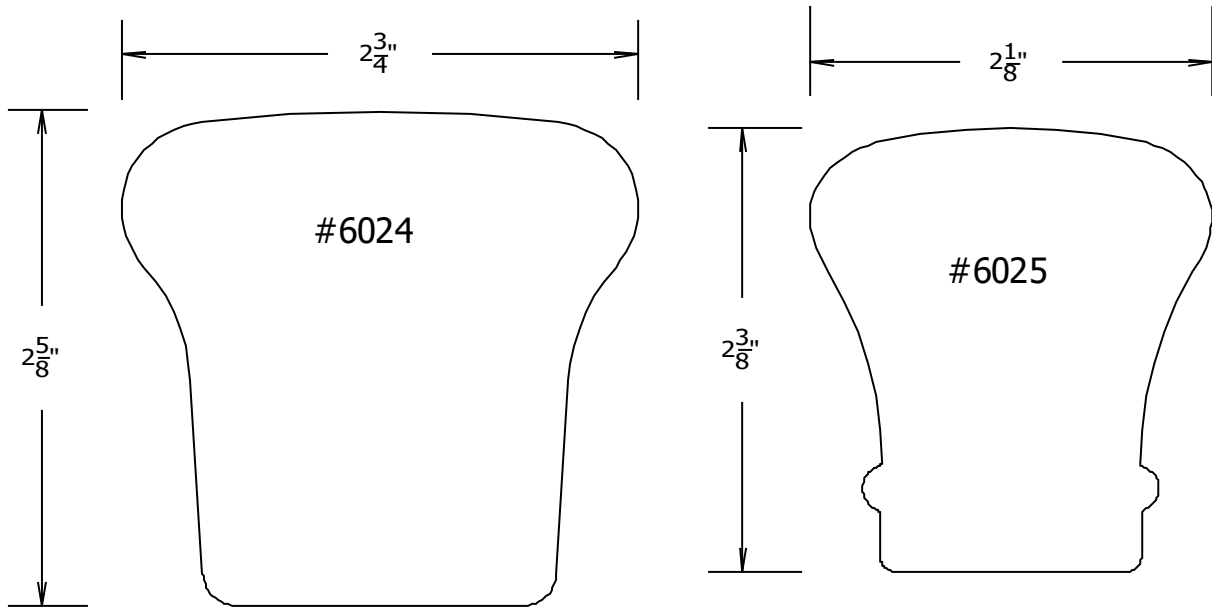
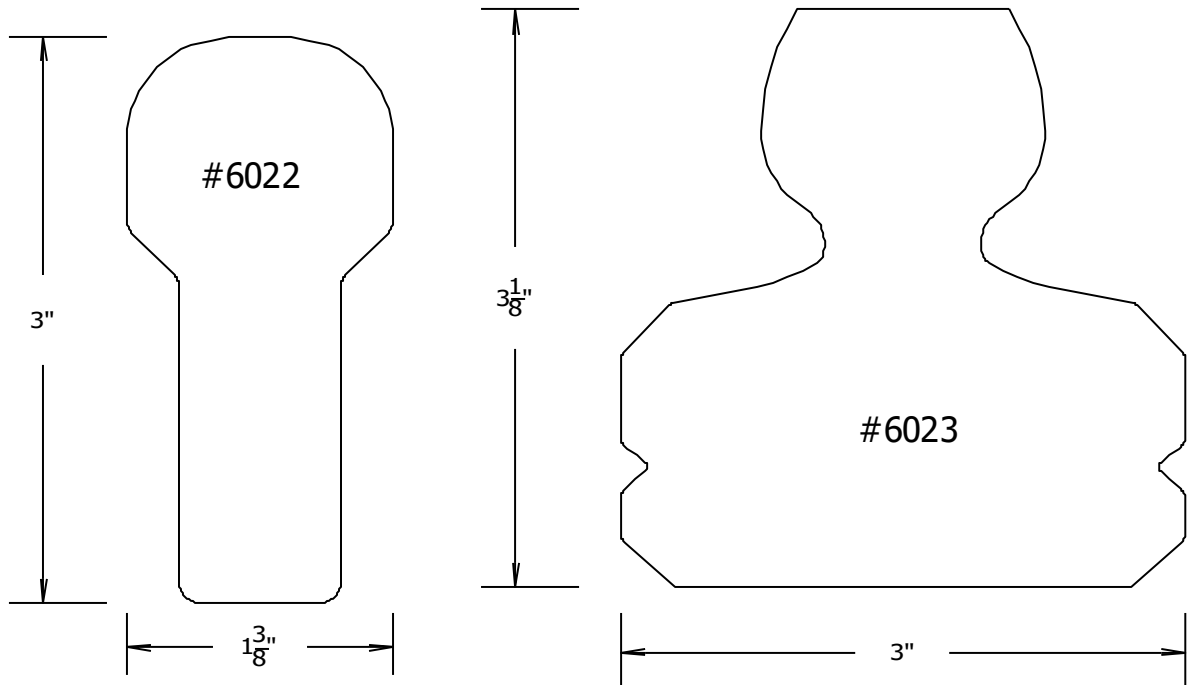

Handrail page #8

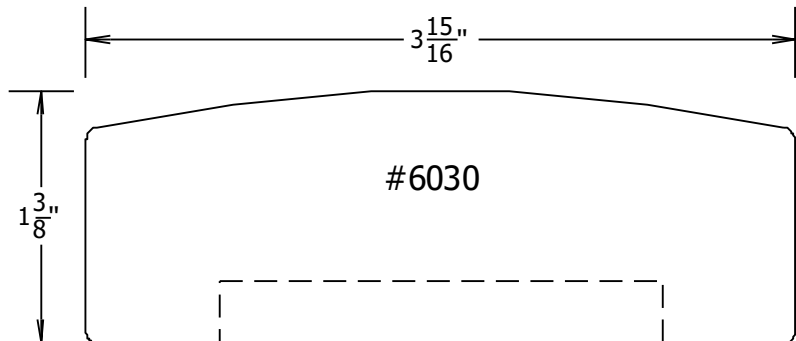
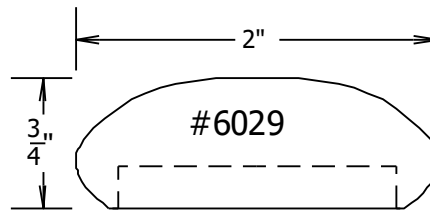
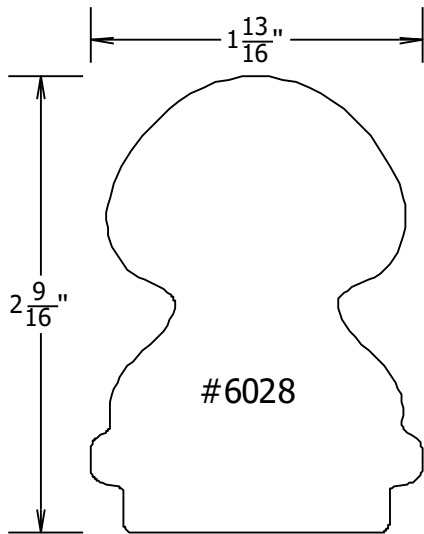
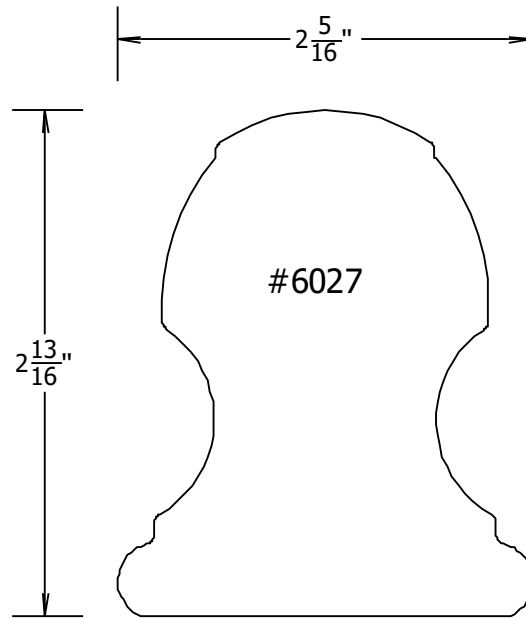
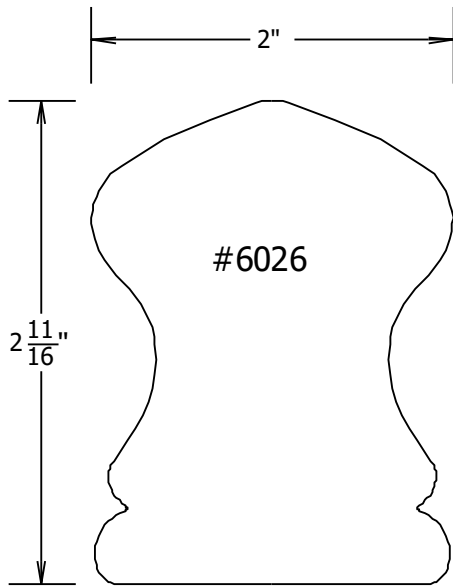

5



Handrail page #9

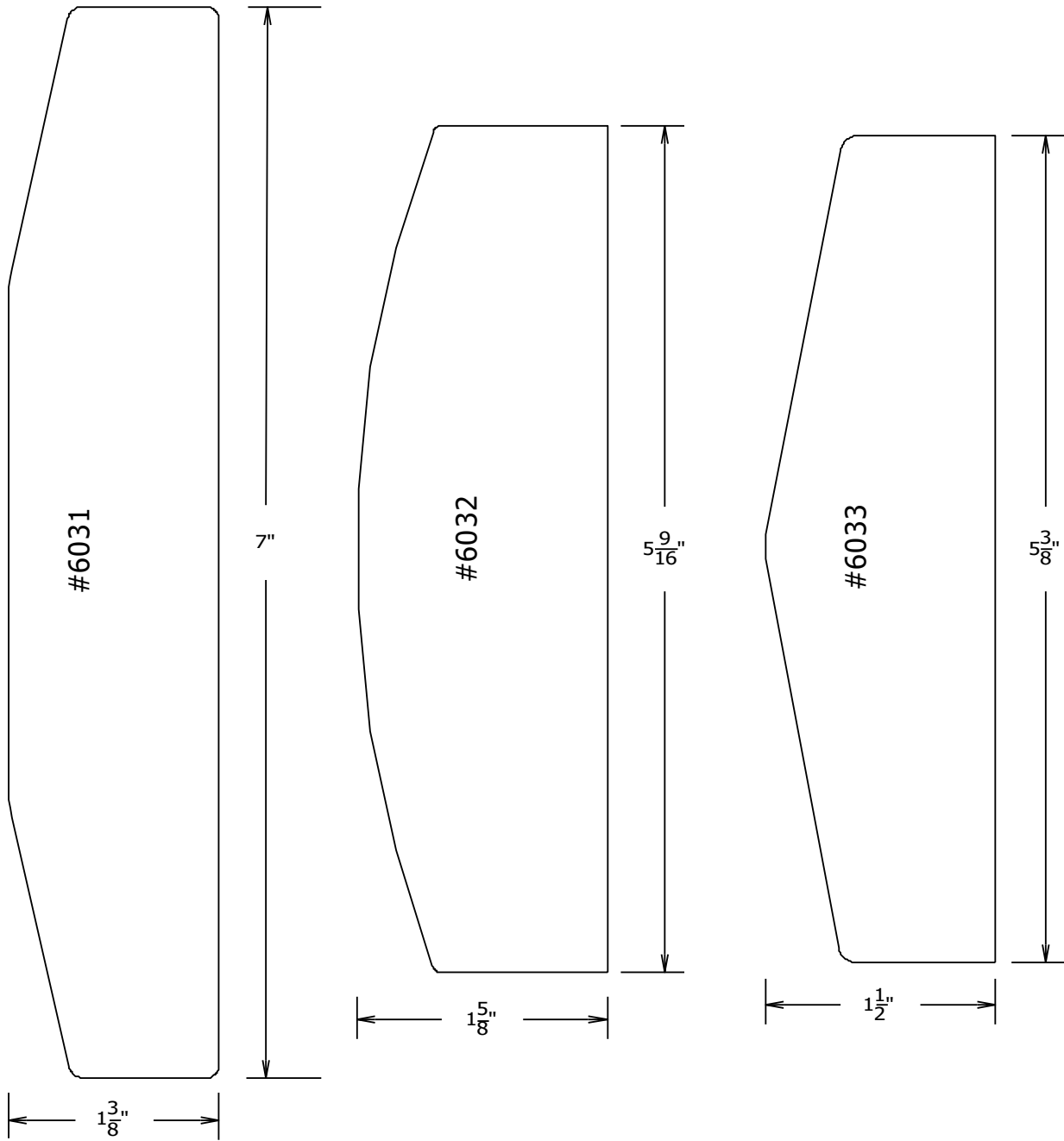

Handrail page #10

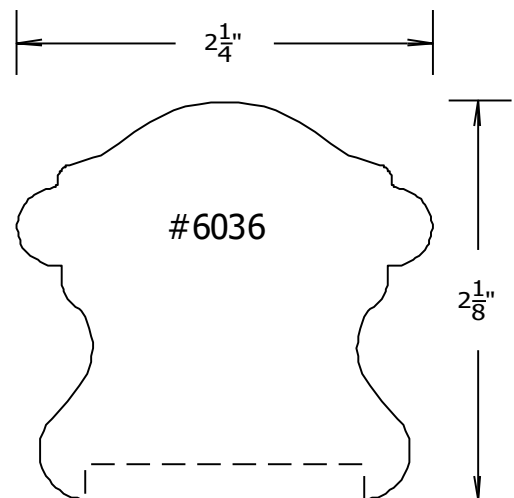
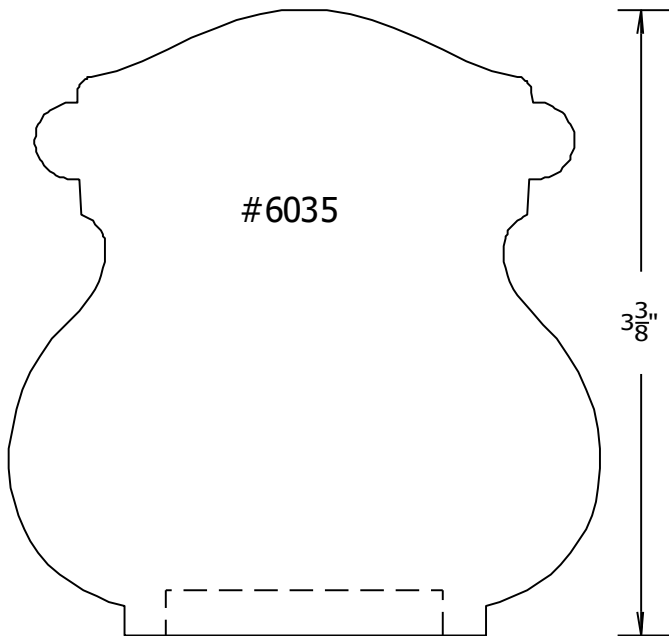
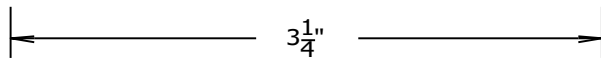
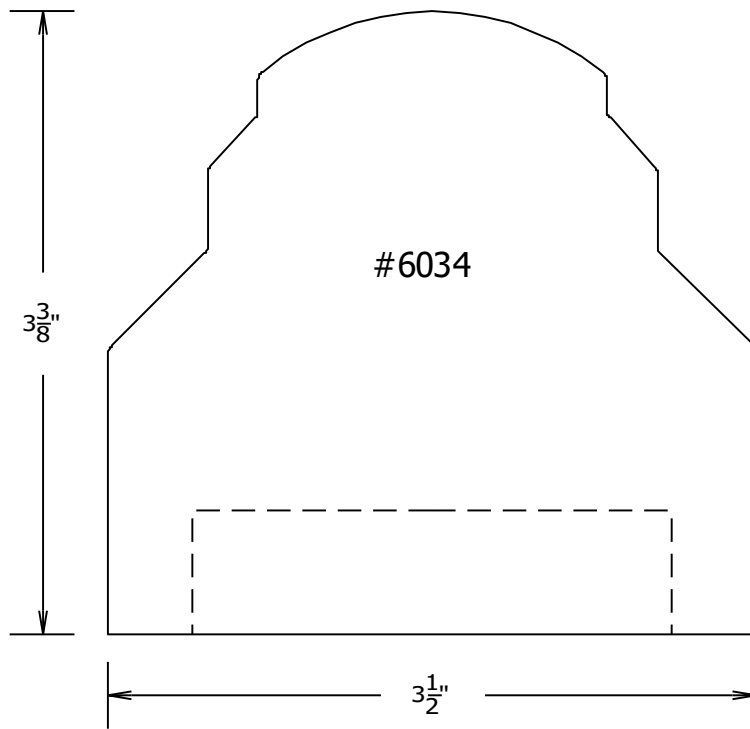

Handrail page #11

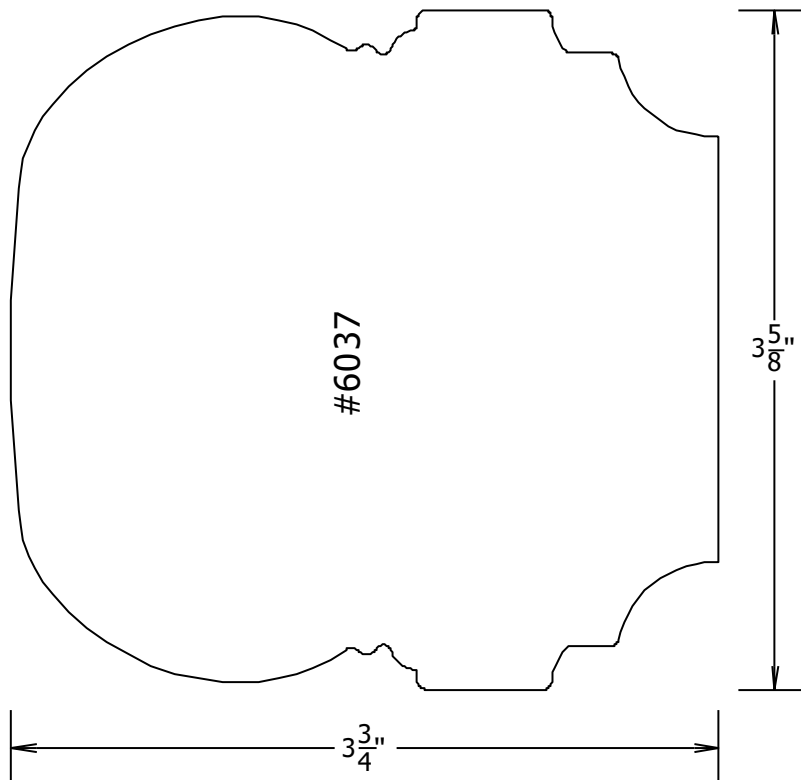
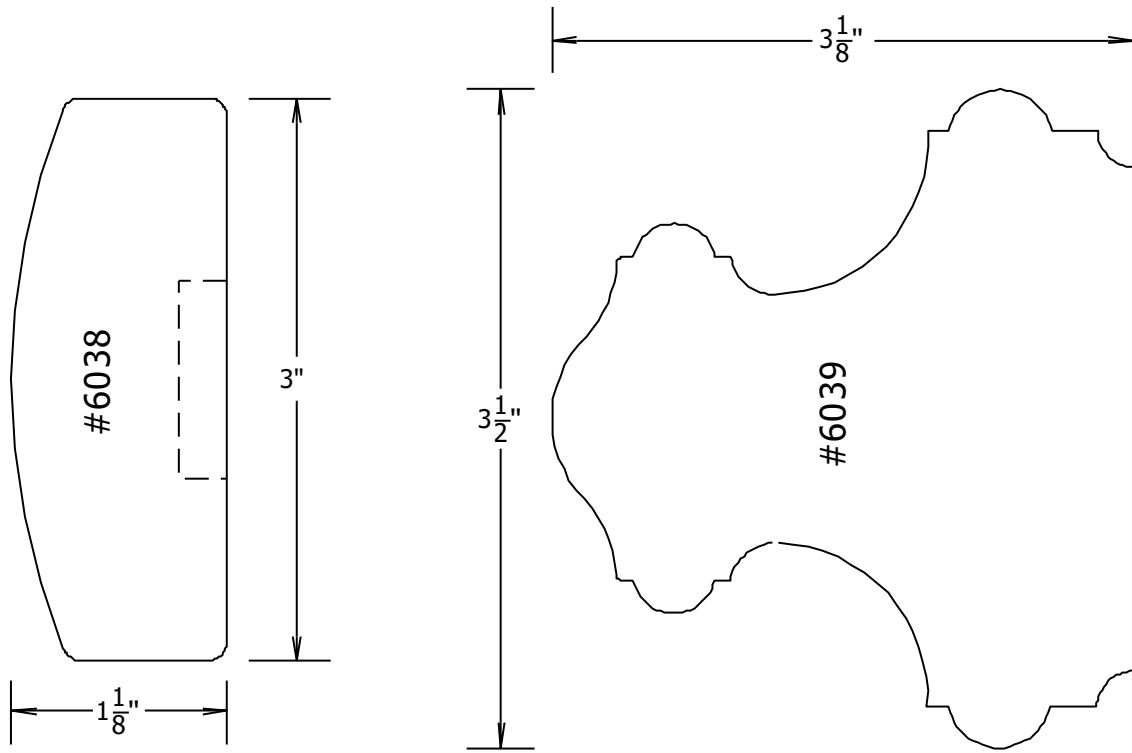

Handrail page #12

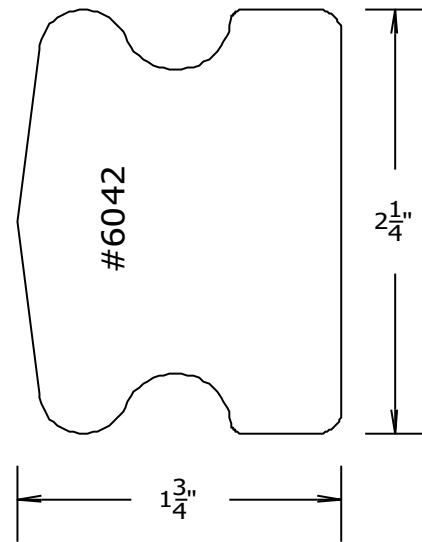
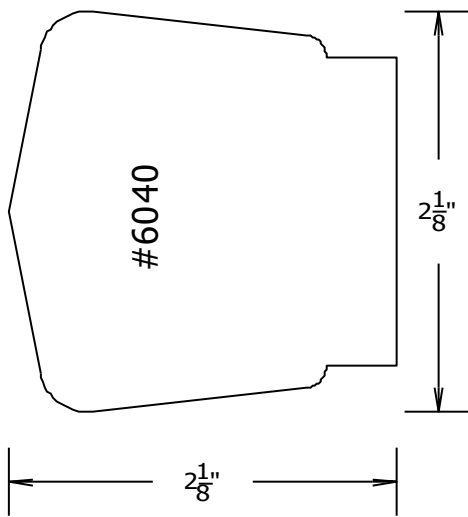
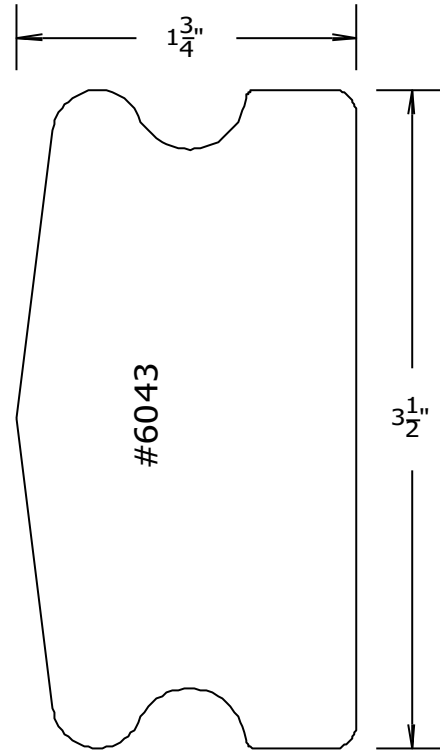
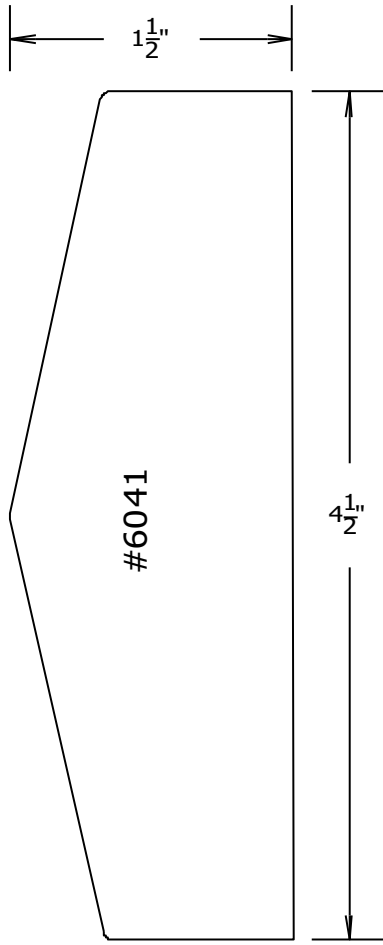

Handrail page #13

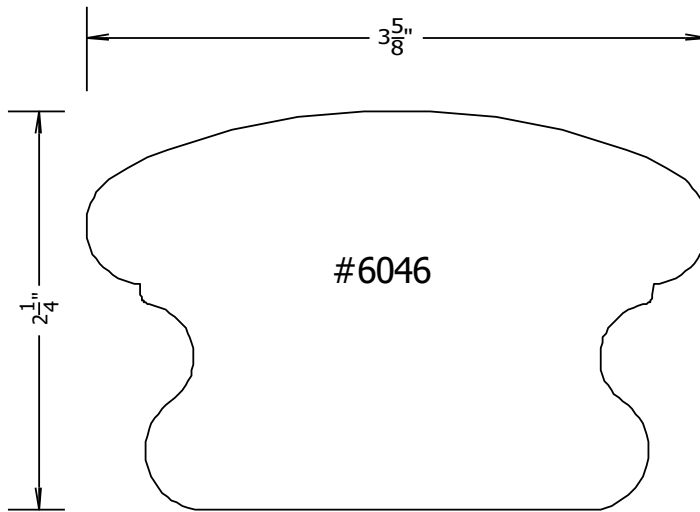
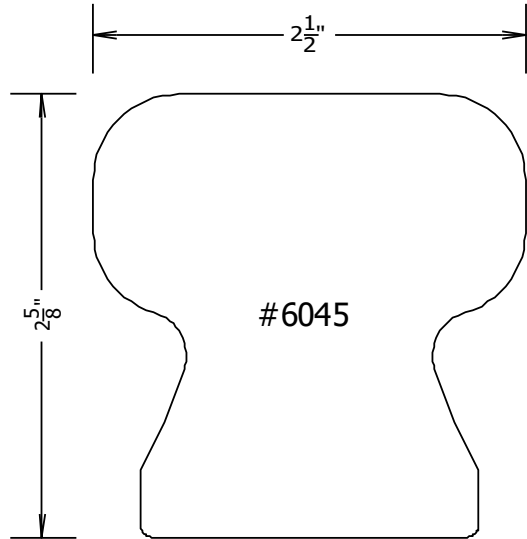
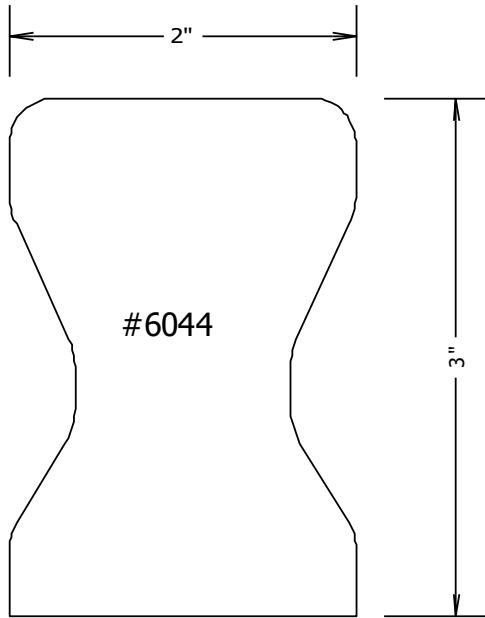

Handrail page #14

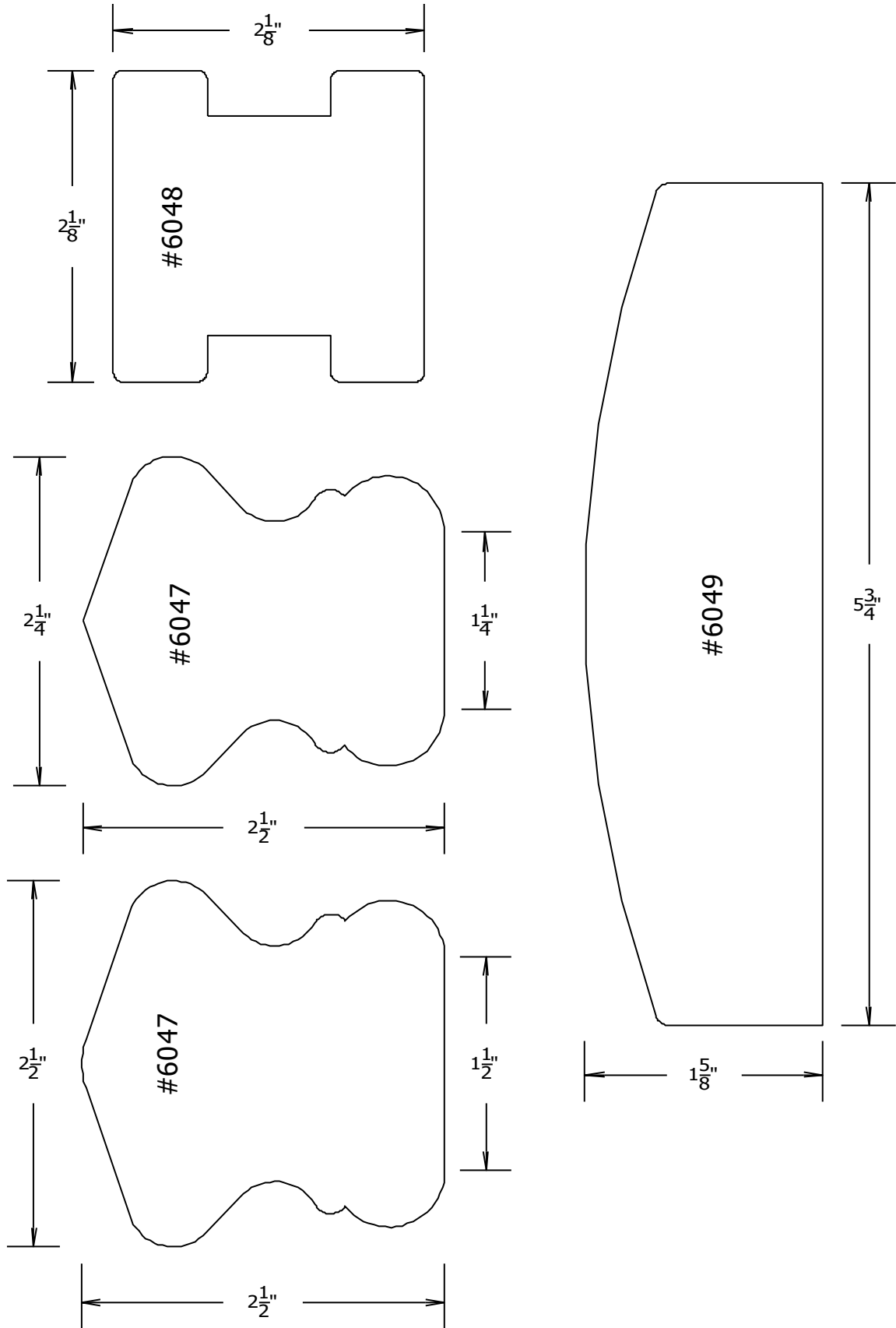

Handrail page #15

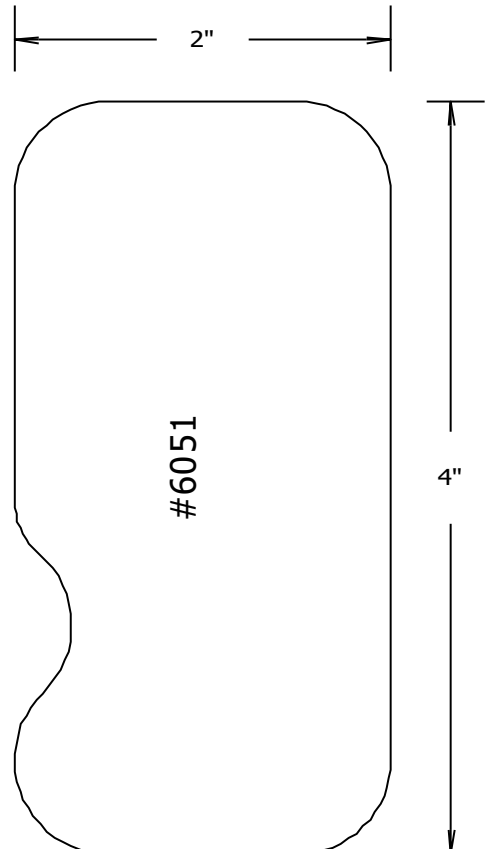
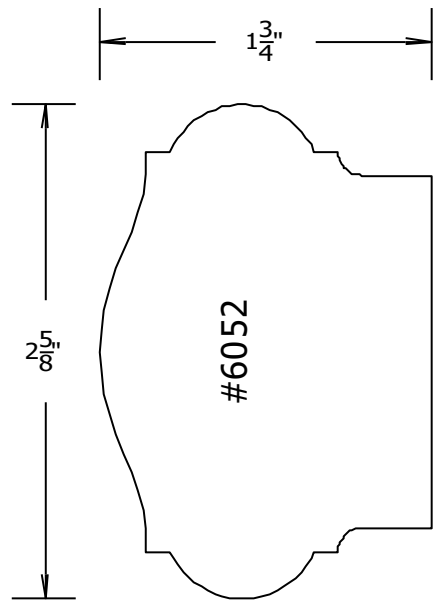
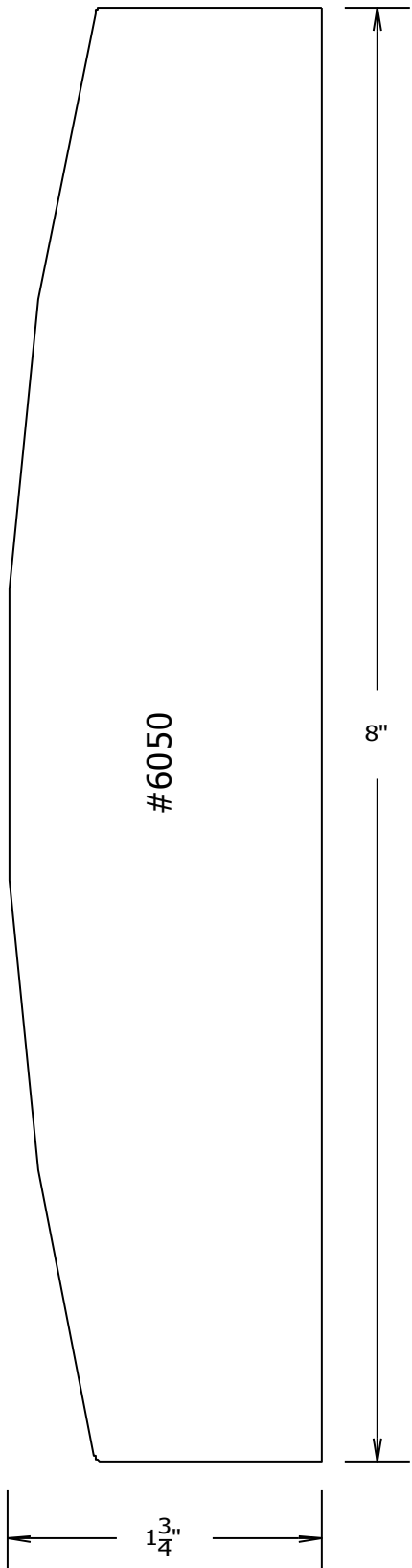

Handrail page #16

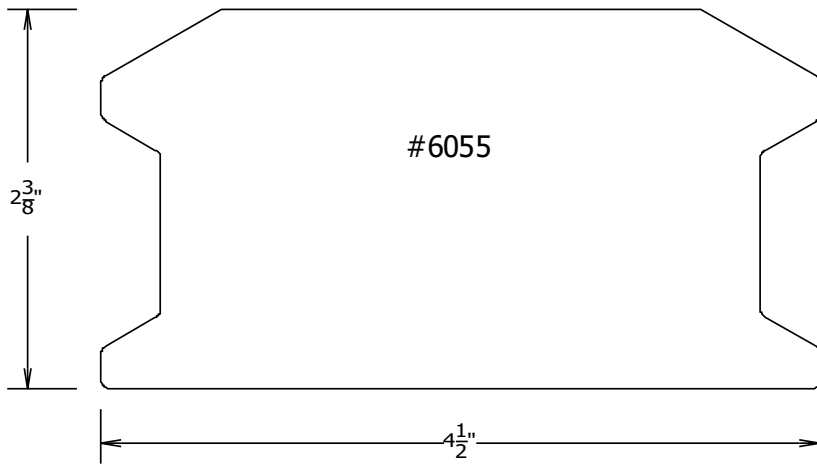
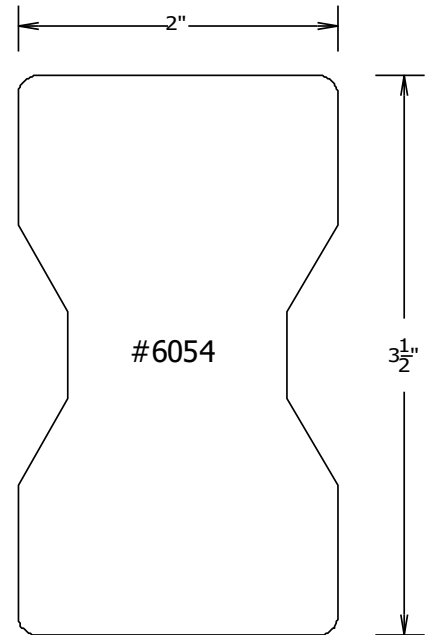
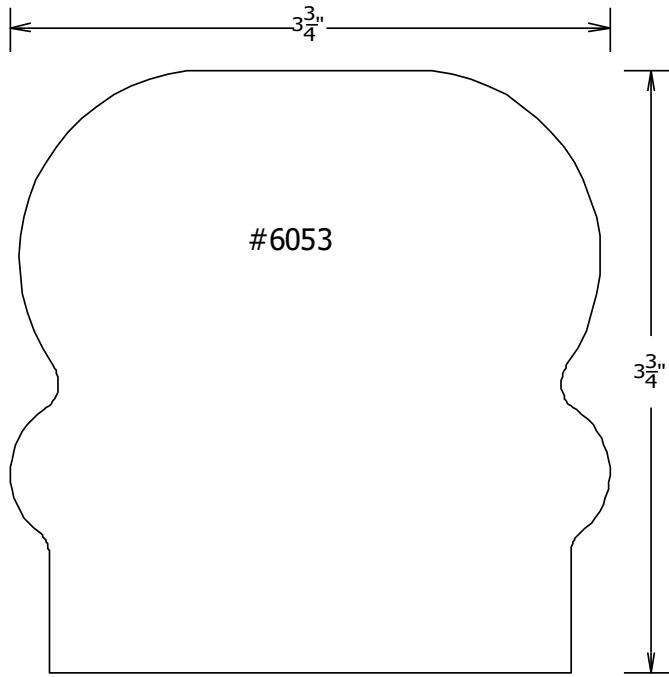



Handrail page #17

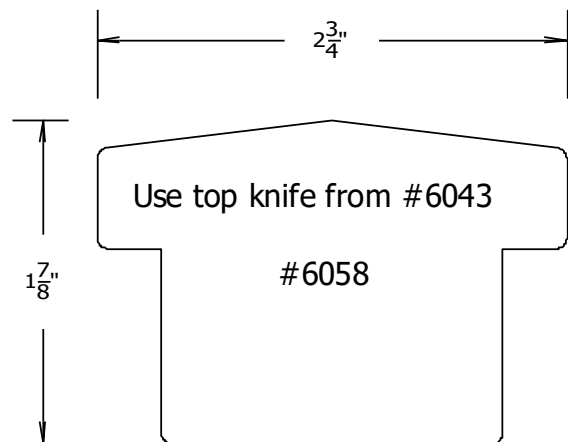
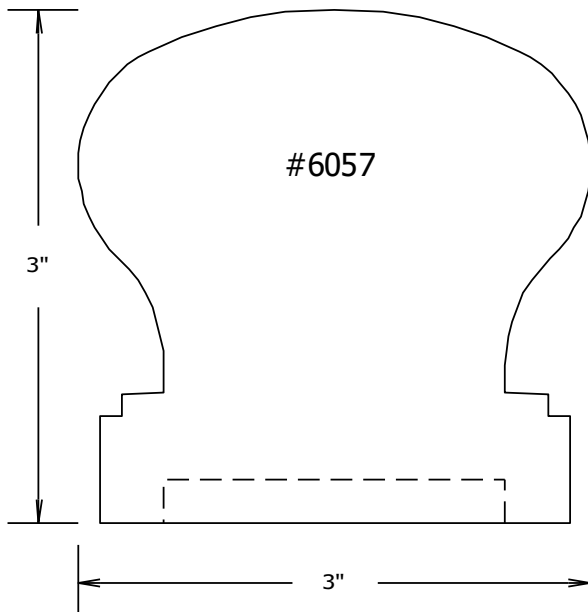
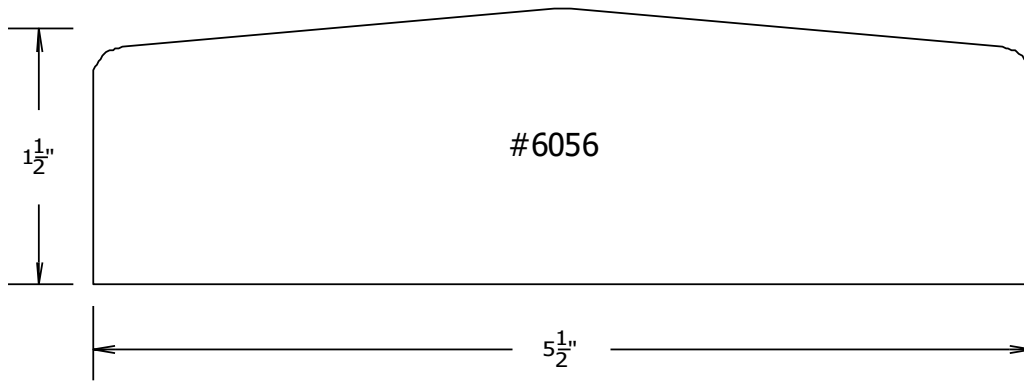
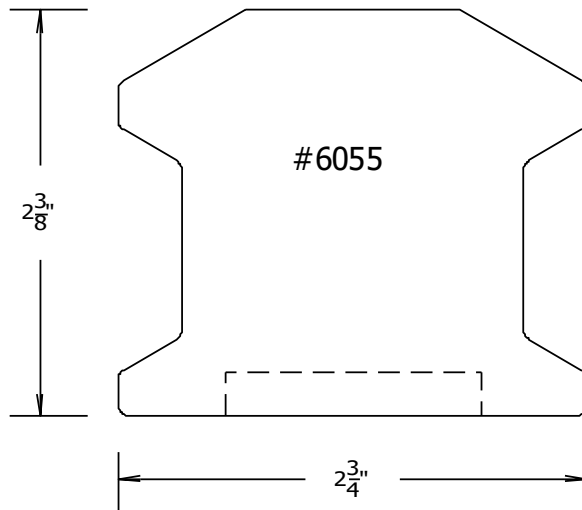

Handrail page #18

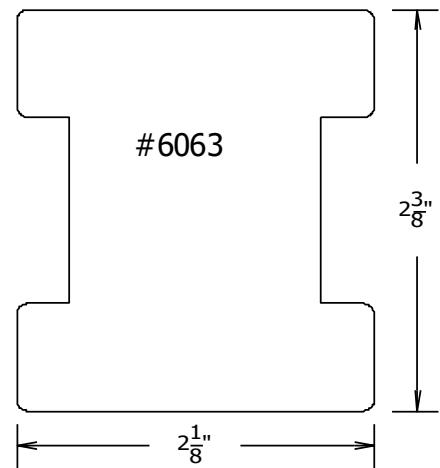
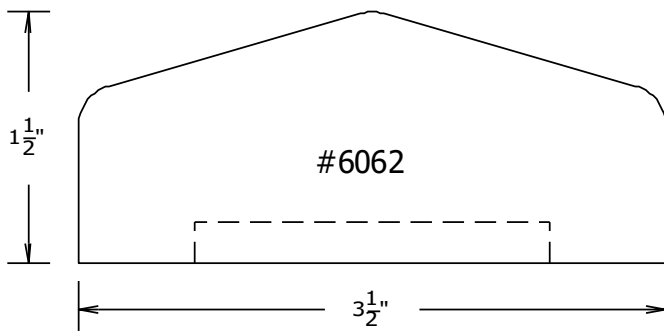
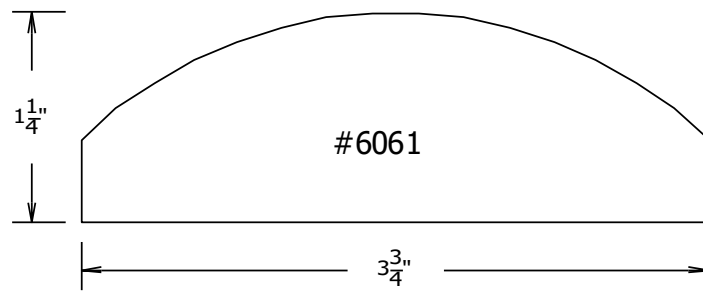
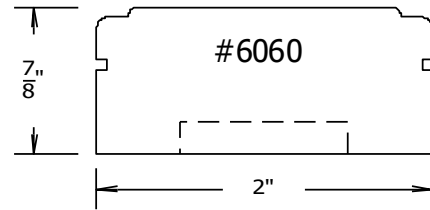
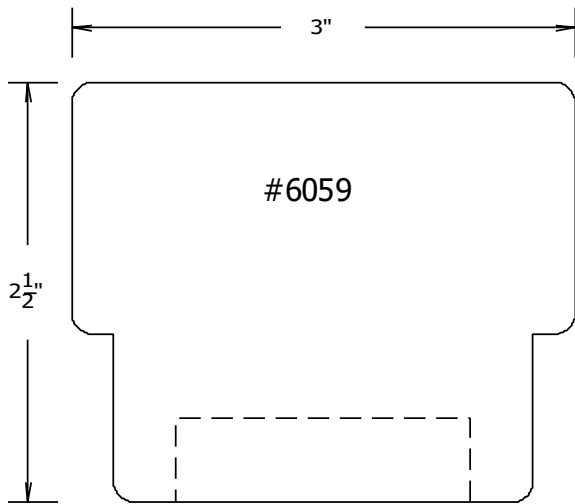

Handrail page #19

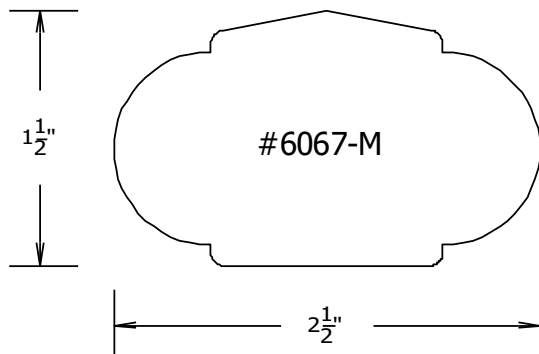
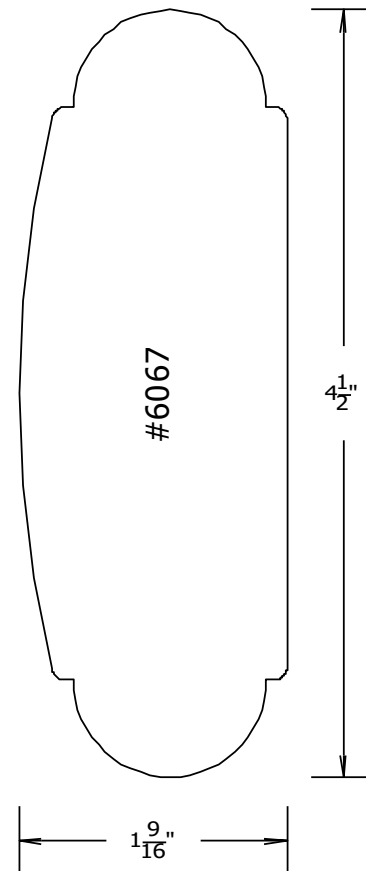
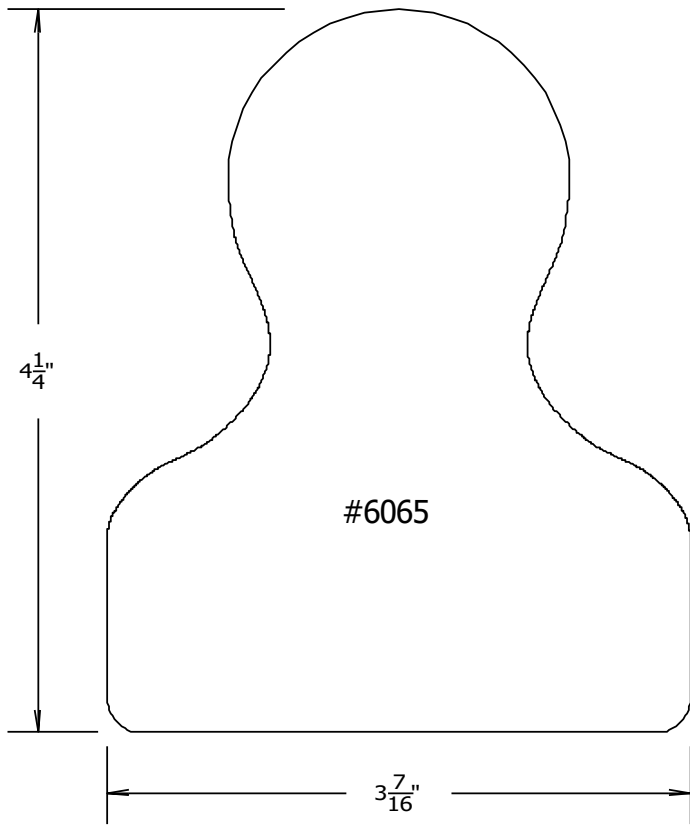
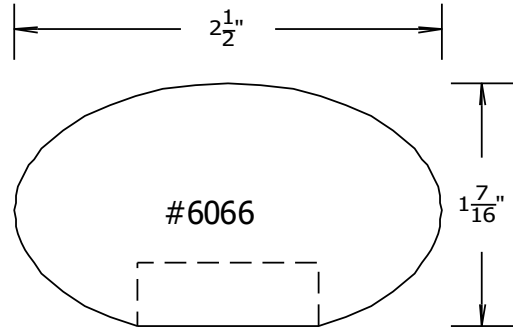
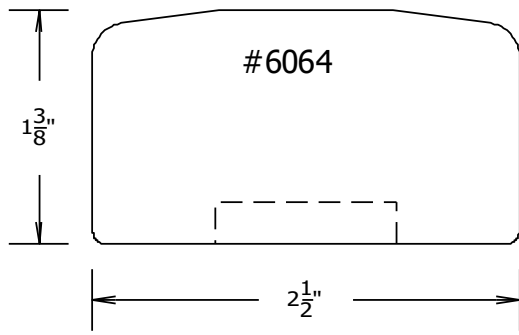

Handrail page #20

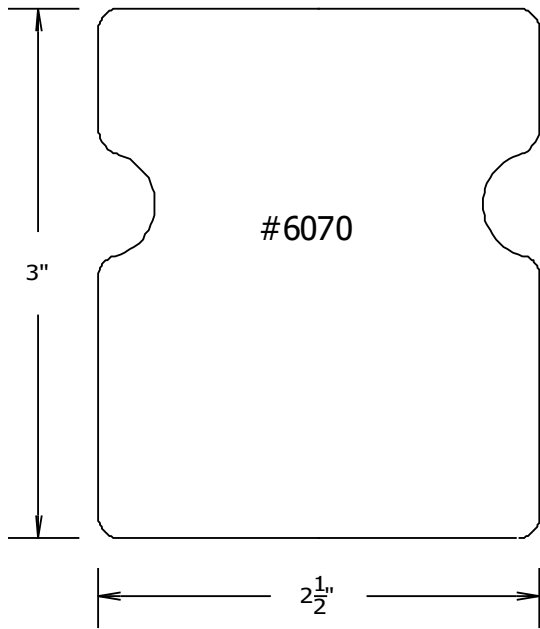
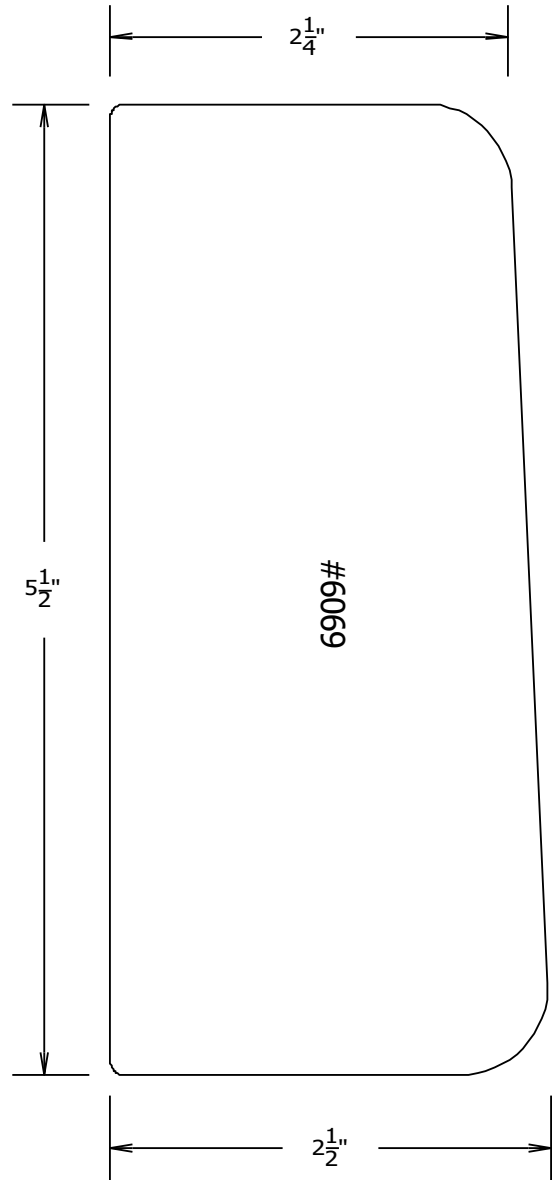
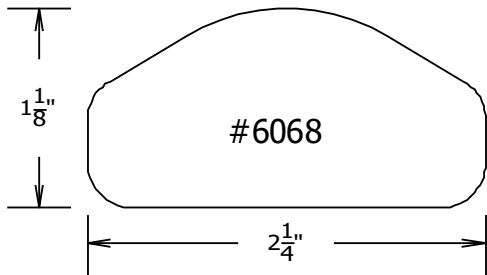

# T & G Pages

Our T & G products are the best matched products you can find.

Most of tongues have a “nail kerf” to allow the nail to be buried without causing interference to the groove.

Let us know if you plan to “pre-finish” your tongue and groove product and we will adjust the fit of the tongue and groove accordingly.

We do not “end match”.

